

# WARHAMMER 40,000

There is no time for peace.

No respite.

No forgiveness.

There is only WAR.



ENGLISH  
www.games-workshop.com  
Printed in China  
WARHAMMER 40,000  
Condensed Rule book  
PRODUCT CODE 60010199005



GAMES  
WORKSHOP

www.games-workshop.com

WARHAMMER 40,000



**F**or more than a hundred centuries the Emperor has sat immobile on the Golden Throne of Earth. He is the Master of Mankind by the will of the gods and master of a million worlds by the might of his inexhaustible armies. He is a rotting carcass writhing invisibly with power from the Dark Age of Technology. He is the Carrion Lord of the Imperium, for whom a thousand souls die every day, for whom blood is drunk and flesh eaten. Human blood and human flesh - the stuff of which the Imperium is made.

To be a man in such times is to be one amongst untold billions. It is to live in the cruellest and most bloody regime imaginable. This is the tale of those times.

It is a universe you can live today - if you dare - for this is a dark and terrible era where you will find little comfort or hope. If you want to take part in the adventure then prepare yourself now. Forget the power of technology, science and common humanity. Forget the promise of progress and understanding, for there is no peace amongst the stars, only an eternity of carnage and slaughter and the laughter of thirsting gods.

But the universe is a big place and, whatever happens, you will not be missed...



There is no time for peace.

No respite.

No forgiveness.

There is only **WAR**.



# WARHAMMER 40,000



# CONTENTS

<b>INTRODUCTION</b> . . . . .	.iii	Assaulting through cover . . . . .	.36	Open-topped vehicles . . . . .	.70
<b>FIGHTING A BATTLE</b> . . . . .	.iv	Grenades . . . . .	.36	Fast vehicles . . . . .	.70
Size of game . . . . .	.iv	Determine assault results . . . . .	.39	Skimmers . . . . .	.71
<b>THE RULES</b> . . . . .	.1	Check morale . . . . .	.39	Walkers . . . . .	.72
<b>DICE</b> . . . . .	.2	Sweeping advances . . . . .	.40	Dreadnought close	
<b>MODELS &amp; UNITS</b> . . . . .	.3	Pile-in! . . . . .	.40	combat weapons . . . . .	.73
Measuring distances . . . . .	.3	Consolidation . . . . .	.40	<b>UNIVERSAL SPECIAL RULES</b> . . . . .	<b>.74</b>
Unit types . . . . .	.4	Shooting into &		Counter-attack . . . . .	.74
<b>CHARACTERISTICS</b> . . . . .	<b>.6</b>	out of close combat . . . . .	.40	Eternal warrior . . . . .	.74
<b>THE TURN</b> . . . . .	<b>.9</b>	Multiple combats . . . . .	.41	Fearless . . . . .	.75
<b>THE MOVEMENT PHASE</b> . . . . .	<b>.11</b>	Close combat weapons . . . . .	.42	Feel no pain . . . . .	.75
Movement distance . . . . .	.11	<b>MORALE</b> . . . . .	<b>.43</b>	Fleet . . . . .	.75
Unit coherency . . . . .	.12	Morale checks . . . . .	.43	Furious charge . . . . .	.75
Terrain . . . . .	.13	Fall back! . . . . .	.45	Hit & run . . . . .	.75
<b>THE SHOOTING PHASE</b> . . . . .	<b>.15</b>	Regrouping . . . . .	.46	Infiltrate . . . . .	.75
Disallowed shooting . . . . .	.15	<b>CHARACTERS</b> . . . . .	<b>.47</b>	Move through cover . . . . .	.75
Run! . . . . .	.16	Independent characters . . . . .	.47	Night vision/acute senses . . . . .	.75
Check line of sight & pick a target . . . . .	.16	Independent characters		Preferred enemy . . . . .	.75
Check range . . . . .	.17	joining & leaving units . . . . .	.48	Rage . . . . .	.76
Roll to hit . . . . .	.17	Special characters . . . . .	.49	Relentless . . . . .	.76
Roll to wound . . . . .	.19	<b>PSYKERS</b> . . . . .	<b>.50</b>	Scouts . . . . .	.76
Take saving throws . . . . .	.20	Force weapons . . . . .	.50	Slow and purposeful . . . . .	.76
Cover . . . . .	.21	<b>UNIT TYPES</b> . . . . .	<b>.51</b>	Stealth . . . . .	.76
Going to ground . . . . .	.24	Monstrous creatures . . . . .	.51	Skilled rider . . . . .	.76
Remove casualties . . . . .	.24	Jump infantry . . . . .	.52	Stubborn . . . . .	.76
Complex units . . . . .	.25	Jetpacks . . . . .	.52	Swarms . . . . .	.76
Multiple-wound models . . . . .	.26	Bikes . . . . .	.53	Tank hunters . . . . .	.76
<b>WEAPONS</b> . . . . .	<b>.27</b>	Jetbikes . . . . .	.53	Turbo-boosters . . . . .	.76
Weapon types . . . . .	.28	Beasts & cavalry . . . . .	.54	Vulnerable to blasts/templates . . . . .	.76
Template . . . . .	.29	Artillery . . . . .	.55	<b>BUILDINGS &amp; RUINS</b> . . . . .	<b>.77</b>
Blast . . . . .	.30	<b>VEHICLES</b> . . . . .	<b>.56</b>	Defining buildings and ruins . . . . .	.77
Pinning . . . . .	.31	Vehicle characteristics . . . . .	.56	Buildings . . . . .	.78
Gets hot! . . . . .	.31	Vehicles & measuring distances . . . . .	.56	Ruins . . . . .	.82
Twin-linked . . . . .	.31	Vehicles and movement . . . . .	.57	<b>ORGANISING A BATTLE</b> . . . . .	<b>.86</b>
Rending . . . . .	.31	Roads . . . . .	.57	Agree points limit & choose forces . . . . .	.86
Sniper . . . . .	.31	Vehicles Shooting . . . . .	.58	Prepare the battlefield . . . . .	.88
Barrage . . . . .	.32	Shooting at vehicles . . . . .	.60	Select a mission . . . . .	.90
Melta . . . . .	.32	Vehicle Damage Table . . . . .	.61	Seize Ground . . . . .	.91
Lance . . . . .	.32	Vehicles & cover . . . . .	.62	Capture & Control . . . . .	.91
<b>THE ASSAULT PHASE</b> . . . . .	<b>.33</b>	Smoke launchers . . . . .	.62	Annihilation . . . . .	.91
Declare assaults . . . . .	.33	Grenades . . . . .	.63	Deploy forces . . . . .	.92
Disallowed assaults . . . . .	.33	Vehicles and assaults . . . . .	.63	Pitched Battle . . . . .	.92
Move assaulting units . . . . .	.34	Vehicles and morale . . . . .	.63	Spearhead . . . . .	.93
Defenders react . . . . .	.34	Units of vehicles – squadrons . . . . .	.64	Dawn of War . . . . .	.93
Fighting a close combat . . . . .	.34	Vehicle types . . . . .	.65	Mission special rules . . . . .	.94
		Transport vehicles . . . . .	.66	<b>REFERENCE</b> . . . . .	<b>.104</b>
		Dedicated transports . . . . .	.67	<b>VICTORY POINTS</b> . . . . .	<b>.116</b>
		Tanks . . . . .	.68	<b>QUICK REFERENCE SHEET</b> . . . . .	<b>.117</b>

# INTRODUCTION

Welcome to the dark future of Warhammer 40,000.

Warhammer 40,000 is far, far more than just a game. It is an engrossing and fulfilling pastime that allows you to collect and paint armies of Citadel miniatures and then use them to fight tabletop battles.

Warhammer 40,000 is set in a savage future age where Mankind must battle for survival in a galaxy riven by destruction and bloodshed. It is a time when the power-armoured Space Marines and the uncountable numbers of the Imperial Guard must stand against the slaving hordes of alien warriors.

The Warhammer 40,000 game puts you in command of a futuristic army of infantry squads, powerful fighting vehicles, mighty heroes, and even monstrous alien creatures. These armies of miniatures do battle over your tabletop, floor, or any area large enough to contain the warring forces.

You will have realised by now that Warhammer 40,000 differs from normal games. There are unlimited possibilities and players must be prepared to expend time and effort collecting, assembling and painting their models and setting up their battlefields. If all this sounds like hard work, you're right – it is! Glory on the battlefields of the far future is not won lightly.

Creating the magnificent spectacle of a fully painted army is an accomplishment one can be rightfully proud of. Once you've taken part in a tightly contested battle between well-painted miniatures raging across fully modelled terrain you'll be hooked. And you'll be joining a community of thousands upon thousands of gamers across the world. If you are anything like us, you will soon be spending endless hours thinking about what to collect next, deciding how to paint your latest model, and devising game-winning tactics for your next battle.



# FIGHTING A BATTLE

▼ A Tau Empire force faces a Tyranid swarm on a beautifully modelled battlefield. Each army totals 1,500 points – about right for an evening's game.

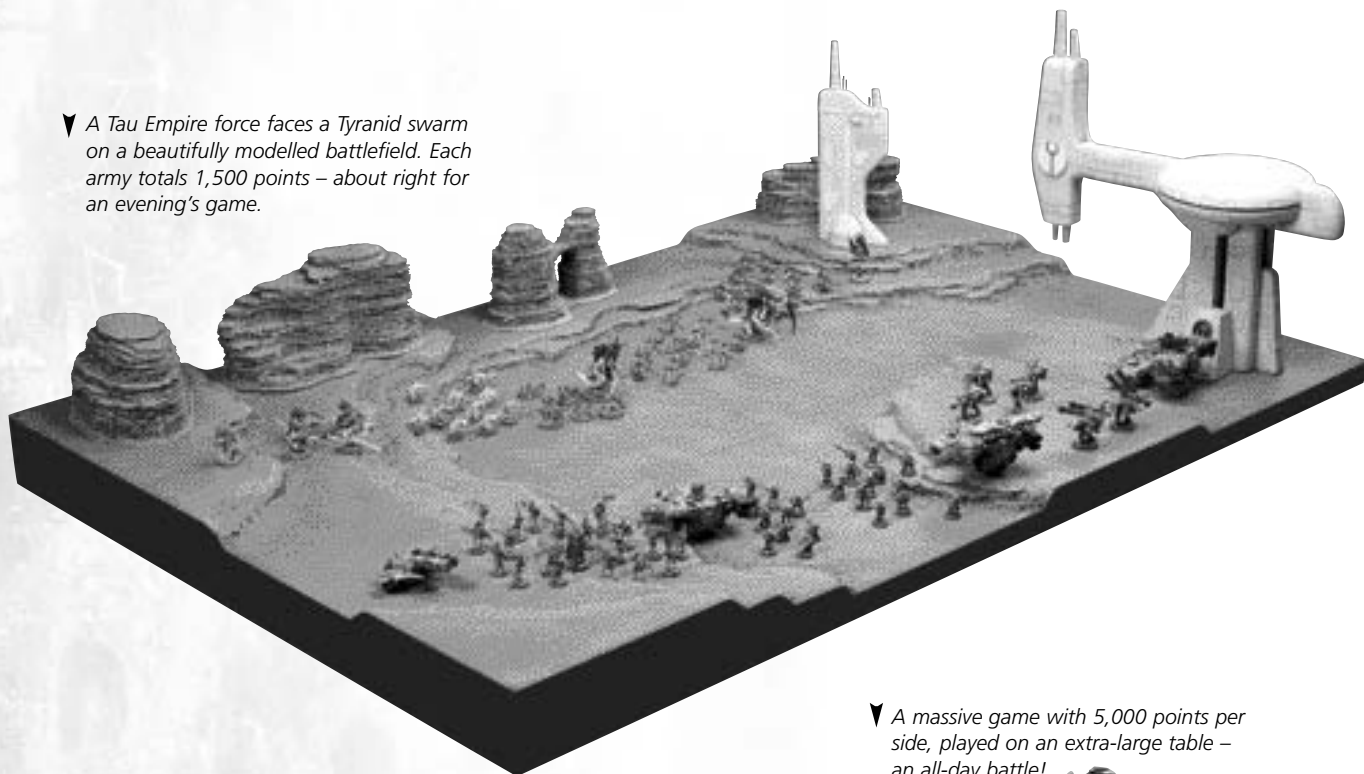

▼ A massive game with 5,000 points per side, played on an extra-large table – an all-day battle!

## SIZE OF GAME

The size of a Warhammer 40,000 battle is determined by three factors – how many models you have to choose from, how much time you can dedicate to the battle, and what type of game or mission you plan on playing.

Generally speaking, in a small game of Warhammer 40,000 each player has an army of between 500-1,000 points. To play out a standard mission for a game of this size will take about an hour. Medium-sized matches of between 1,000-2,000 points usually take an evening to finish. Large battles of over 2,000 points can take all day or even longer.

Very experienced (or plain ambitious) players will even play matches of enormous size with added unique mission rules. These massive battles may last a weekend or longer and will almost certainly require a gaming space where models can be left standing over night!





◀ For your first few games, using a small army will keep things manageable. This small force is composed of a Space Marine Chaplain and a Tactical squad – roughly 250 points-worth.

▶ A multi-player bash, using 1,000 points each. The winner gets free drinks all night!





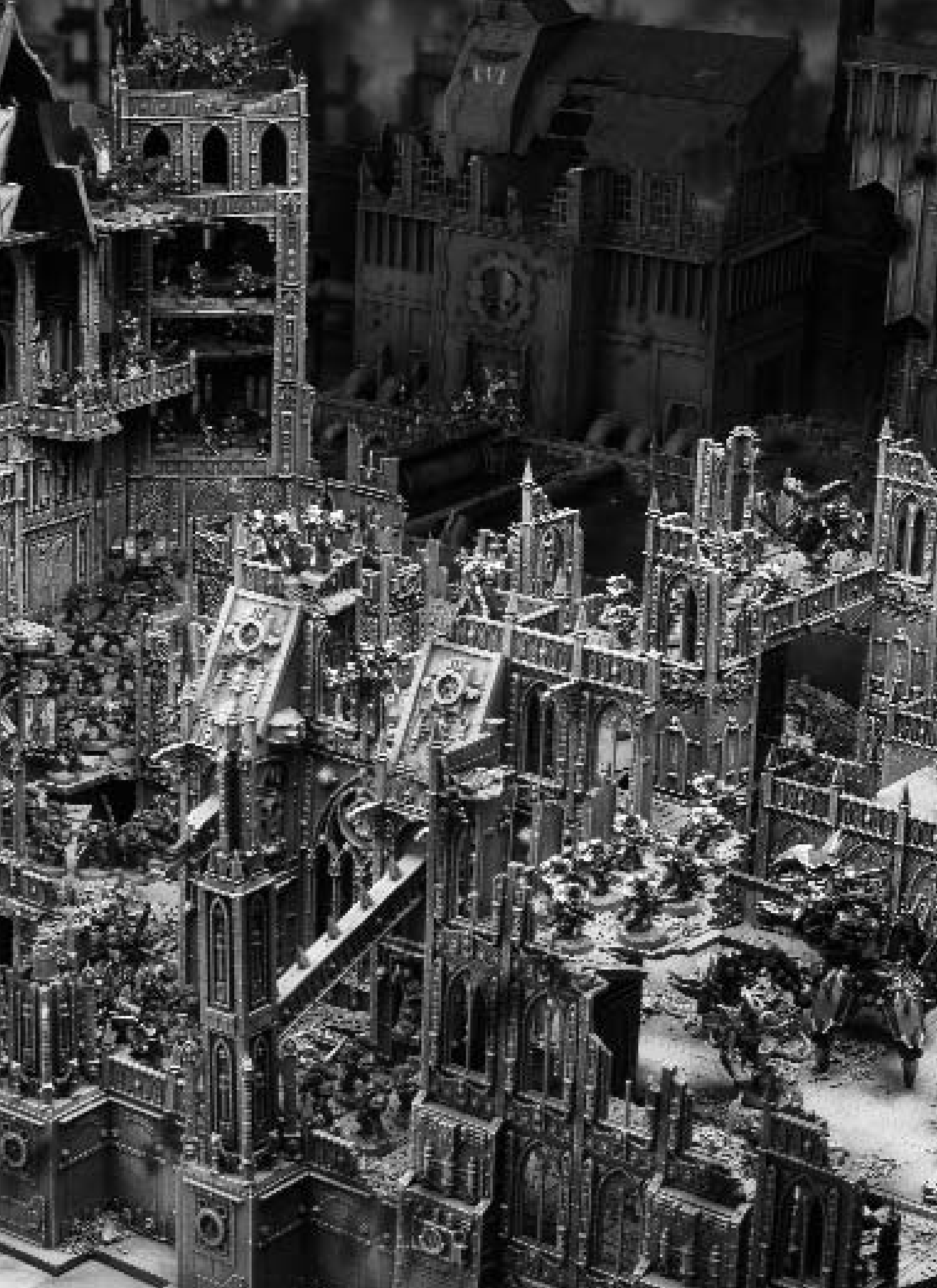

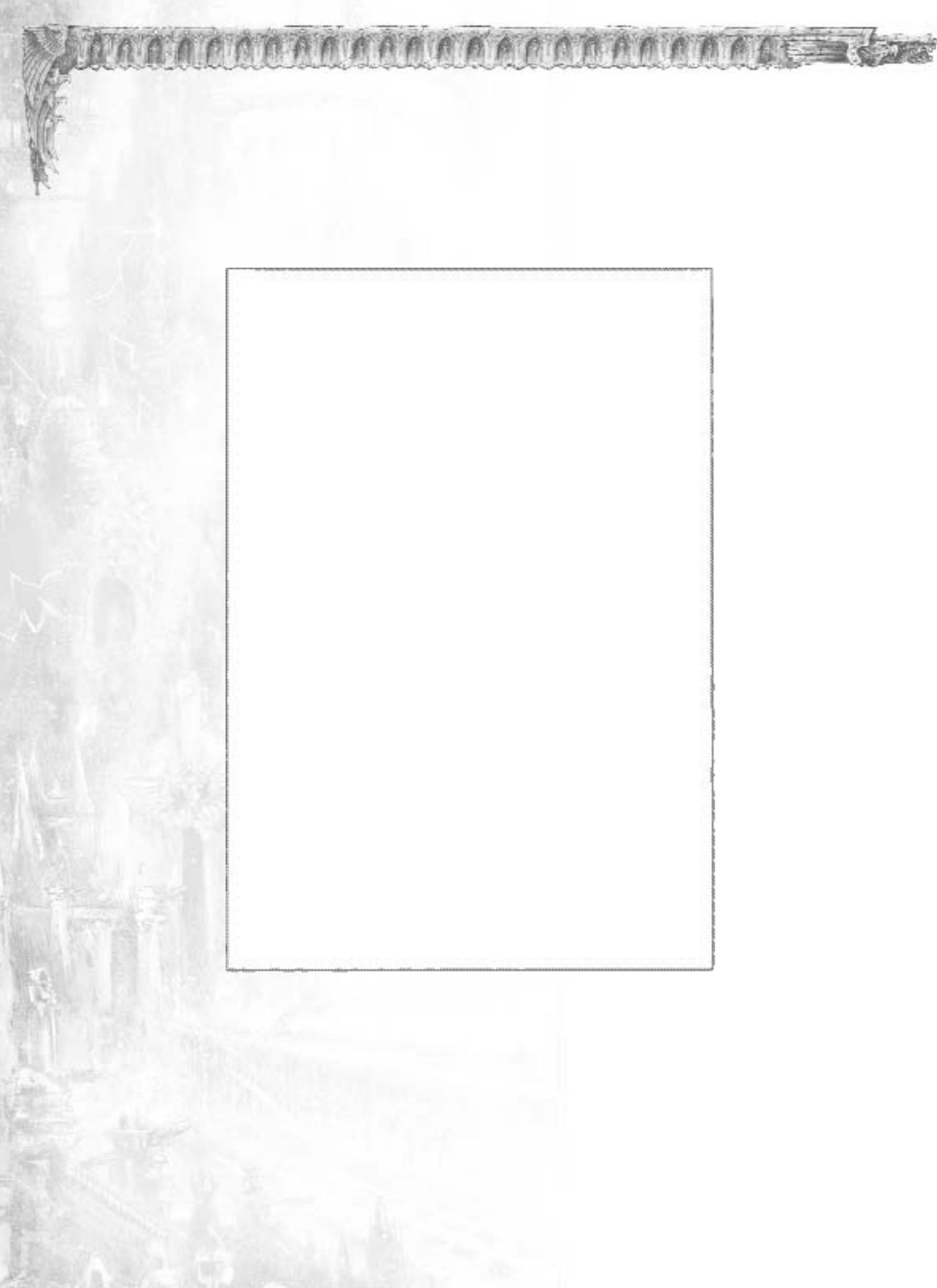

## **THE MOST IMPORTANT RULE!**

*Warhammer 40,000 is an involving game, with many different armies, weapons and possibilities. In a game of this size and complexity there are bound to be occasions where a particular situation lies outside these rules, often when unusual models interact. At other times you may know the rule is covered but you just can't seem to find the right page. Then again you may know the rule, but the reality of exactly where your models are on the table may make it a really close call – measuring assault moves and deciding if a key model is in cover are classic examples.*

*All of these instances can lead to arguments, so it is important to remember that the rules are just a framework to create an enjoyable game. Winning at*

*any cost is less important than making sure both players – not just the victor – have a good time. If a dispute does crop up then work out the answer in a gentlemanly manner. Many players simply like to roll-off and let the dice decide who is right, allowing them to get straight back to blasting each other to pieces. After the game you can happily continue your discussion of the finer points of the rules, or agree how you will both interpret them should the same situation happen again. You could even decide to change the rules to suit you better (this is known as a 'house rule').*

*The most important rule then is that the rules aren't all that important! So long as both players agree, you can treat them as sacrosanct or mere guidelines – the choice is entirely yours.*

# DICE

## **DICE (D6)**

In a Warhammer 40,000 battle you often need to roll dice to see how the actions of your models turn out – how effective their shooting is, what damage they've done to a vehicle, how far they fall back from enemy fire, and so on. Almost all of the dice rolls in Warhammer 40,000 use standard six-sided dice (usually referred to as 'D6').

## **ROLLING A D3**

In rare circumstances you may be told to roll a D3. Since there's no such thing as a three-sided dice, use the following method for determining a score between 1 and 3. Roll a D6 and halve the score, rounding up. Thus 1 or 2=1, 3 or 4=2 and 5 or 6=3.

## **RE-ROLLS & ROLL-OFFS**

### **Re-rolls**

In some situations the rules allow you a 're-roll' of the dice. This is exactly as it sounds – pick up the dice you wish to re-roll and roll them again. The second score counts, even if it means a worse result than the first, and no single dice can be re-rolled more than once regardless of the source of the re-roll. If you re-roll a 2D6 or 3D6 roll, you must re-roll all of the dice and not just some of them, unless the rule granting you the re-roll explicitly specifies otherwise.

### **Roll-offs**

If the rules require players to roll-off, this simply means that each player rolls a dice and the player that scores the highest result wins the roll-off. If the players roll the same result, both dice must be rolled again until one player is the winner.

## **MODIFYING DICE ROLLS**

Sometimes, you may have to modify the result of the dice roll. This is noted as D6 plus or minus a number, such as D6+1 or D6-2. Roll the dice and add or subtract the number to or from the score to get the final result. For example, D6+2 means roll a dice and add 2 to the score, giving a total of between 3 and 8.

You may also be told to roll a number of dice in one go, which is written as 2D6, 3D6, and so on. Roll the indicated number of dice and add the scores together, so a 2D6 roll is two dice rolled and added together for a score of between 2-12. Another method is to multiply the score of a dice by a certain amount, such as D6x5 for a total between 5 and 30. Finally, a combination of methods may be used, such as 3D6-3 giving a total of 0-15.

## **SCATTER DICE**

Some weapons are fairly random in their accuracy and require you to roll a scatter dice to determine where their shots land. The scatter dice is marked on four sides with an arrow, and on two sides with a special 'HIT' symbol. Simply roll the scatter dice near the target point – if an arrow is rolled this shows in which direction the shot has deviated. If a HIT symbol is rolled this means the shot is bang on target. Some weapons may scatter automatically, with no chance of a direct hit, in which case you will find a small arrow on the HIT side to determine the direction.

---

**Reason begets doubt;  
doubt begets heresy.**

---

# MODELS & UNITS

## MODELS

The Citadel miniatures used to play games of Warhammer 40,000 are referred to as 'models' in the rules that follow. Each model is an individual playing piece with its own capabilities. Models represent an enormous variety of troops ranging from Gretchin, the small, weak slaves of the Orks, to noble Space Marines, the protectors of Mankind, to Wraithlords, mighty Eldar constructs containing the souls of the dead. To represent all these differences, each model has its own characteristics profile as described in the next section.

## BASES

Citadel miniatures are normally supplied with a plastic base. If so, they must be glued onto their bases before they can be used in the game.

Some players like to mount their models on impressive scenic bases. As mounting your models on different-sized bases might affect the way they interact with the rules, make sure before the game that your opponent does not mind this.

## UNITS

Warriors tend to band together to fight in squads, teams, sections or similarly named groups – individuals do not normally go wandering off on their own for obvious reasons! In Warhammer 40,000, we represent this by grouping models together into units.

Units fight in loose groups with gaps between each model. This gives the troopers the freedom to move over difficult terrain quickly, and enables them to take advantage of such things as minor folds in the ground, scrub, and other small features, to shelter from enemy fire. Similarly, artillery batteries consist of large guns and the crew that fire them, vehicle squadrons are made up of a number of vehicles and so on. The different elements of the unit have to stay together to remain an effective fighting force. This is detailed more fully in the Movement section (see page 12).

A unit will usually consist of several models that fight as a group, but it can also be a single, very large or powerful model, such as a battle tank, a monstrous alien creature or a lone hero. In the rules that follow, all of these things are referred to as 'units'. The different types of unit are detailed overleaf.

Thought for the day:

**Wisdom is the beginning of fear.**

## MEASURING DISTANCES

A model is considered to occupy the area of its base, so when measuring distances between two models, use the closest point of their bases as your reference points. For models supplied without a base (like some large vehicles) use the model's hull or body instead.

When measuring distances between two units, use the closest models as your reference points, as shown in the diagram below. So, for example, if any model in a unit is **within 2"** of an enemy unit/model, the unit is said to be **within 2"** of that enemy unit/model.

In general, players are not allowed to measure any distance except when the rules call for it (e.g. after declaring an assault or firing at an enemy, to work out a rule's area of effect, when deploying their forces, etc).

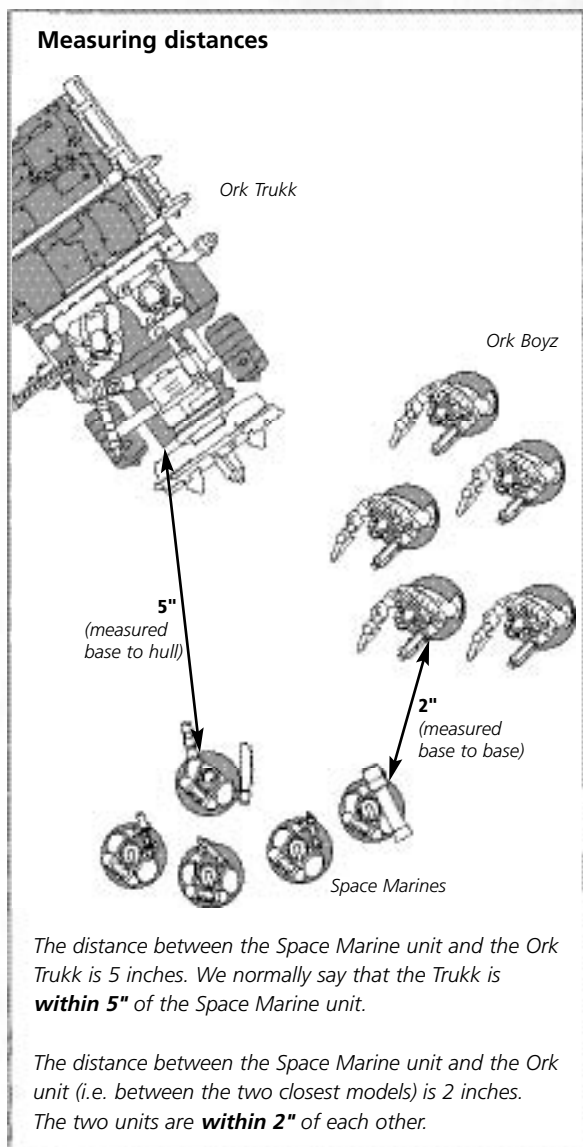

# UNIT TYPES

In order to make it easier to learn the basic rules, the first few sections of the book, covering **Movement, Shooting, Assault and Morale** are written with respect to infantry units, because these are by far the most common unit type in the game. The other types of unit are also defined here and then explained in detail later in specific sections that cover their unique rules. The unit types in Warhammer 40,000 are as follows:

## INFANTRY

Infantry units include all types of foot soldiers, whether human or alien. A typical unit of infantry is between five and ten models strong but can be much larger. In rare cases, an infantry unit may comprise only a single model. Infantry are fairly slow moving, but can cross almost any terrain (given enough time) and make the best use of cover to avoid enemy fire. Infantry are the most common and dependable units in Warhammer 40,000 and the bulk of the rules are concerned with them.



*Space Marines of the Ultramarines Chapter*



*Flesh Hound of Khorne*

## BEASTS AND CAVALRY

Consisting of particularly vicious hunting animals or a rider with a living mount, beasts and cavalry are able to swiftly carry the battle to the enemy. Beasts and cavalry have a profile like other infantry, but are able to make use of a special faster move when they assault an enemy unit.

Beast and cavalry units are typically quite rare and small in number. Just like bikers, cavalry riders may not dismount during the game and so have a characteristic profile that takes into account both the beast and rider. We assume that if one is killed, the other is also incapacitated or simply flees the battlefield.

## MONSTROUS CREATURES

Some creatures are just too big to fit into the ordinary infantry unit category. These are towering giants that are capable of crushing a tank – like the Tyranid Carnifex, a creature bio-engineered and evolved to become a living battering ram. While monstrous creatures use many of the infantry rules, their size and destructive capability make them a lot more dangerous. Fortunately for their foes, a monstrous creature unit will usually consist of a single model.



*Tyranid Carnifex*



*Blood Angels  
Assault Marine*



*Ork Zzap Gun and Gretchin crew*

## JUMP INFANTRY

Jump infantry are equipped with jump packs, jet packs, wings, teleport devices or other means of moving quickly over short distances. They commonly take advantage of these by dropping onto the battlefield in the midst of the enemy – heroically or foolishly depending on your perspective. Jump infantry can move like normal infantry or activate their jump device to make a high-speed move, leaping over intervening terrain and models. Jump infantry tend to be a rare and valuable commodity in most armies.

## BIKES AND JETBIKES

These units are riders mounted on a variety of conventional bikes or jetbikes. They are capable of moving really quickly, and will often have weapon systems built onto their bikes. Both types of bike manoeuvre much faster than infantry and jetbikes are able to glide over obstructions, such as buildings, without being slowed. Their only major weakness is the risk of crashing when moving through terrain. Note that, to keep things simple, riders may not dismount during the game and therefore these models have a combined characteristic profile that factors in both the bike and rider.



*Eldar Jetbike*

## VEHICLES

Vehicle units include all kinds of war machines. Battle tanks, grav-tanks, Monoliths and Dreadnoughts all fall into this category. Most vehicles can move more rapidly than infantry but need to stick to open ground to avoid getting bogged down. Vehicle units are represented by single models in the case of tanks and other large vehicles, or as a group of smaller vehicles. Vehicle crew members – the drivers, commanders and gunners – are assumed to be an integral part of their machine, and if their vehicle is destroyed they are considered to be lost along with it. Note that bikes and jetbikes have their own unit type, and are not counted as vehicles.



*Imperial Guard Leman Russ  
battle tank*

# CHARACTERISTICS

In Warhammer 40,000, there are many different types of warriors, ranging from the mighty Space Marines to the brutal Orks, the agile Eldar to the dreaded Tyranids. To represent the different abilities of these creatures in the game, each model has a profile made up of nine numbers that describe the various aspects of their physical and mental make-up. These are called characteristics.

The characteristics are: Weapon Skill (WS), Ballistic Skill (BS), Strength (S), Toughness (T), Wounds (W), Initiative (I), Attacks (A), Leadership (Ld) and Armour Save (Sv).

For all models except vehicles these characteristics are given a value on a scale of 0 to 10 – the higher, the better (except for a model's Armour Save, where the opposite is true!).

Certain pieces of wargear or special rules may modify a model's characteristics positively or negatively, by adding to it (+1, +2, etc.) or even multiplying it (x2, x3, etc.). However no modifier may raise any characteristic above 10 or lower it below 0. Saves can at best be modified to 2+.

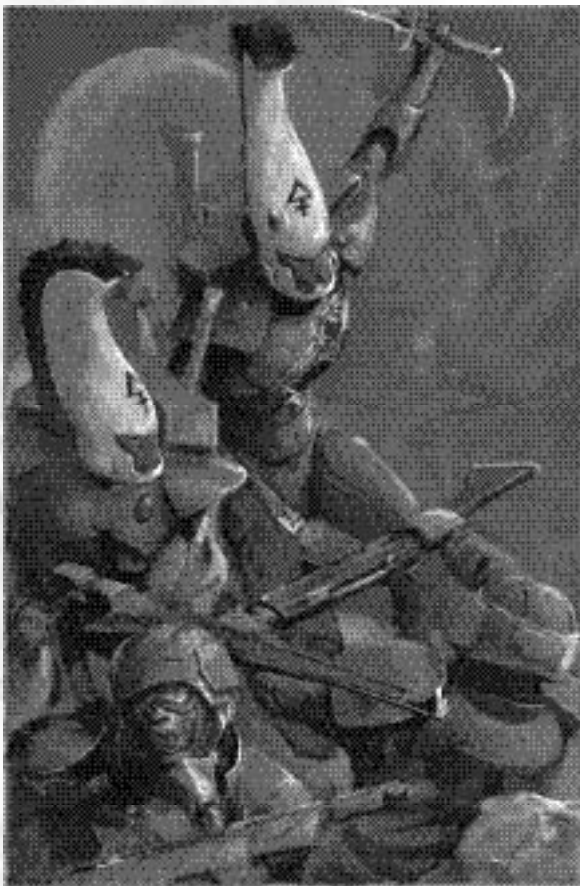

## WEAPON SKILL (WS)

This characteristic defines how skilled and vicious a warrior is with his weapons in close combat. The higher the score, the more likely the warrior will land blows on a close combat opponent. An average human soldier has WS3, while a genetically-enhanced Space Marine will have WS4 or even WS5.

## BALLISTIC SKILL (BS)

Ballistic Skill shows how accurate a creature is with ranged attacks, such as guns, rockets or energy weapons. The higher this score is, the easier a creature finds it to hit when it shoots at something. Some monsters have natural weapons that can be used at range (they may be able to spit venom, for example) and their BS is also used to determine whether they hit or not.

## STRENGTH (S)

Strength shows how physically strong a creature is. An exceptionally puny creature may have a Strength of 1, a deadly Wraithlord has S10 and most humans have S3. Strength tells us how hard a creature can hit in close combat and therefore how easily it can hurt an enemy.

## TOUGHNESS (T)

Toughness measures a creature's ability to resist physical damage and pain, and includes such factors as the thickness of its flesh, hide or skin. The tougher a creature, the better it can survive enemy blows or shots. A human is T3, while a resilient Ork is T4.

## WOUNDS (W)

Wounds show how much damage a creature can take before it either dies or is so badly hurt it can't fight any more. Most man-sized creatures have only a single Wound. Heroes and large monsters are often able to withstand several injuries that would slay a lesser creature, and so have a Wounds value of 2, 3, or more.

## INITIATIVE (I)

How alert a creature is and how quickly it reacts is shown by its Initiative. In close combat, faster creatures gain a massive advantage over slower ones because they get to strike first. A normal human is Initiative 3, while an agile Eldar Aspect Warrior is Initiative 5.

## ATTACKS (A)

Warriors of exceptional skill and particularly ferocious monsters can unleash a flurry of blows against their opponents. This characteristic indicates the number of dice a model rolls when fighting in close combat. This is normally 1 for most models, but a heroic leader or a large monster can have 3 or even more Attacks. The number of Attacks a creature makes may be increased if it has the added impetus of assaulting into its foes or is fighting using two weapons, for example.

## LEADERSHIP (LD)

The Leadership (Ld) of most warriors is around an average value of 7 or 8. A creature with a higher Leadership value is courageous, steadfast, or very well-trained. A creature with a lower value is temperamental, unpredictable or cowardly. Models that represent generals, heroes, sergeants and other such characters often have a high Leadership that allows them to lead others, inspiring them on to greater feats of valour.

## ARMOUR SAVE (SV)

A creature's Armour Save (Sv) gives it a chance of avoiding harm when it is struck or shot. Most creatures have an armour save based on what kind of armour they are wearing, so this characteristic may be improved if they are equipped with better armour. Other creatures may receive a natural saving throw from having thick bony plates or a chitinous shell.

## VEHICLE CHARACTERISTICS

The Warhammer 40,000 universe is home to all sorts of tanks, war machines and other combat vehicles, both human-built and alien. To reflect the many differences between creatures of flesh and blood and constructs of steel and iron, vehicles have many different rules and their own set of characteristics. Vehicle characteristics are described in the Vehicles section (see page 56).

## ZERO-LEVEL CHARACTERISTICS

Some creatures have been given a '0' for certain characteristics, which means that they have no ability whatsoever in that field (the same is also occasionally represented by a '-'). This usually applies to creatures unable to use missile weapons, and so they have a BS of 0, but it might apply to other characteristics too. A defenceless model will have no Attacks whatsoever, while a model with WS0 will be hit automatically by his enemies in close combat. A warrior with an Armour Saving Throw of '-' has no armour save at all.

## CHARACTERISTIC PROFILES

Each model in Warhammer 40,000 has a profile that lists the value of its characteristics. At the back of this book, and in the Codex books for each army, you will find profiles for many races and creatures.

Below are the profiles for an Ork Boy and a Space Marine of the Imperium:

	WS	BS	S	T	W	I	A	Ld	Sv
Ork Boy	4	2	3	4	1	2	2	7	6+
Space Marine	4	4	4	4	1	4	1	8	3+

As you can see, they are similar in some respects. They have the same Weapon Skill and the same Toughness value. They both have 1 Wound, which is the norm for man-sized creatures. The Ork has more Attacks in close combat, representing its great ferocity,

but when it comes to BS, S, I, Ld and Sv, the Space Marine is superior. The Space Marine's Ballistic Skill of 4 means that he will hit more often when shooting. In hand-to-hand combat, the greater Strength value gives the Space Marine a better chance of killing the Ork and his superior Initiative means that he gets to strike first. The Space Marine has a Leadership of 8, which is slightly higher than the average. The Space Marine's thicker armour gives him another marked advantage over the Ork, as most shots or blows that hit the Space Marine are deflected on a D6 roll of 3 or more. The Ork instead needs a result of 6 to be saved by its primitive type of armour.

Obviously, an Ork is no match for a Space Marine when fighting one-on-one, but, as Orks are usually found in large numbers, they can be lethal opponents, even for Space Marines!

## MULTIPLE MODIFIERS

If a model has a combination of rules or wargear that both add to and multiply one of its characteristics, first multiply the basic value and then add the extra points. For example, if a model with Strength 4 has both '+1 Strength' and 'double Strength', its final Strength will be 9 ( $4 \times 2 = 8$ ,  $8 + 1 = 9$ ).



## CHARACTERISTIC TESTS

During a battle, a model might have to take a test on one of its characteristics, commonly its Strength, Toughness or Initiative. For example it might have to test its Toughness to resist the effects of a lethal gas.

In order to take the test, roll a D6. To succeed, you must score equal to or lower than the value of the characteristic involved. Note that if a 6 is rolled, then the model automatically fails the test regardless of the characteristic's value or any other modifier that might apply, and conversely a 1 is always a success.

Of course, if a model has to take a test for one of its characteristics with a value of 0, it automatically fails.

## LEADERSHIP TESTS

Tests made against the Leadership characteristic (like Morale checks) are different from other tests. In the case of a Leadership test, roll 2D6 (two dice added together, as explained earlier). If the result is equal to or less than the model's Leadership, the test is passed.

If a unit includes models with different Leadership values, always use the one with the highest Ld value.

Modifiers may apply to the Leadership characteristic in particularly trying circumstances – for example, -1 if the unit suffered wounds from an Ordnance barrage weapon, as described later.

## POINTS VALUES

Generally, you'll find characteristic profiles come along with one other piece of information – the model's points value. This represents the relative battlefield value of the creature in question. Points values take into account a number of different factors including characteristics, different races' overall strengths and weaknesses, basic weapons, unit size, rarity and so forth. Choosing forces that are worth a specific points total allows players to organise an evenly matched battle.

For comparison, a Space Marine is worth 15 points, and an Ork is 6 points. This means that an Ork horde would normally outnumber a Space Marine force by more than two to one. It is just as well that Space Marines are really hard!



# THE TURN

**A tremendous amount of action takes place in a battle: squads are constantly manoeuvring and shooting, tanks rumble into action and artillery fire roars overhead in a torrential downpour of destruction. A game of Warhammer 40,000 represents the ebb and flow of battle but, in order to turn the chaos into a manageable game, players alternate taking turns moving and fighting with their units. So, one player will move and fight with his forces first, then his opponent will move and fight. Then the process repeats with the first player moving and fighting again, and so on until the end of the game.**

During his turn, a player can usually move and fight with all of his units. For convenience, moving, shooting and fighting in close combat are dealt with one after the other. This means that you move all of the models you want to first, then you shoot with any who can, and finally you resolve all close combats. This process helps to keep track of what is going on and makes it easier to know when one player's actions are over and his opponent can start his turn.

## GAME TURNS AND PLAYER TURNS

In a complete game turn, both players get a player turn, each one divided into Movement, Shooting and Assault phases (see Turn Sequence, below). Exactly what is going to happen in each phase is described in the following sections of this book.

### THE TURN SEQUENCE

#### 1 The Movement phase

The player can move any of his units that are capable of doing so. See the Movement rules for more details of how to move your forces.

#### 2 The Shooting phase

The player can shoot with any of his units that can see an enemy. See the Shooting rules for more details about how to resolve this.

#### 3 The Assault phase

The player can move any of his units to assault the enemy if they are close enough. Assaults are bloody, desperate affairs where units are fighting in close combat. This means that both forces can fight in an Assault phase, but only the player whose turn it is can move into an assault. The Assault rules will tell you more about them.

Hence one game turn will comprise two player turns. Whenever a rule uses the word 'turn', both in this rule book and in the Codexes, it means 'player turn', otherwise it will clearly state 'game turn'.

*So, for example, in game turn 1 a player will take his player turn 1 and go through his Movement, Shooting and Assault phases. Then the other player will take his player turn 1 and go through his Movement, Shooting and Assault phases, thus ending game turn 1. Game turn 2 will then follow.*

## WHO GETS THE FIRST TURN?

Which player gets the first turn of the game can be determined in a number of different ways. Normally, both players roll a D6 and the player with the highest score deploys his army first and then takes the first player turn. The mission you are fighting will specify exactly how this works. Fighting a variety of different missions is covered in more detail in the Organising a Battle section, on page 90.

## THE END OF THE GAME

The standard missions presented in this book last a random number of game turns (five to seven turns), determined by a dice roll. However the final section of the book includes ideas for creating your own missions, which could end in a number of ways. A battle could last a specific number of game turns, so that both players know when the end is nigh.

Alternatively, players might be able to win a 'sudden death' victory that ends the game immediately – for example, if they destroy the power generator they win straight away. You could also decide to end a battle at a pre-set time if you only have a limited amount of time to play in.

## VICTORY

Once the game is finished, the players determine who has won, as dictated by the mission they are playing (see the Organising a Battle section on page 90). For now it is enough to know that Warhammer 40,000 standard missions generally revolve around capturing tactical objectives or inflicting the most damage upon the enemy.

## TURN SEQUENCE EXCEPTIONS

There are times when a player is allowed to perform actions during their opponent's turn (fighting in an assault being the most common example). It may also be convenient to interrupt a player's turn because of some event occurring, like a booby trap being triggered. Whatever the reason, after the interruption, the turn sequence always continues as normal.



# THE MOVEMENT PHASE

**Although the Movement phase is the easiest to perform, it's probably the most tactically important. Getting models into the right position on the battlefield is often the key to victory. For the time being we'll just explain how squads of infantry move, as they are by far the most common units in the game. Vehicles, jump infantry, bikes and certain other units move in different ways to represent their greater mobility, and these will be discussed in detail later.**

In his turn, a player may move any of his units – all of them if he wishes – up to their maximum movement distance. Once a unit has completed all of its movement, the player selects another unit and moves that one, and so on, until the player has moved all of the units he wishes to move. Note that a player doesn't have to move all (or indeed any) of his units. A unit that doesn't move is often more effective at shooting, as we will explain later in the rules. Once you have started moving a unit, you must finish its move before you start to move another unit. You may not go back and change the move already made by a previous unit.

## MOVEMENT DISTANCE

Infantry move up to six inches (6") in the Movement phase. This represents most creatures moving at a reasonable pace but stopping several times to scan the surrounding landscape for enemies, communicate with their commanders, etc. Even warriors who are moving in a part of the battlefield where no enemies are apparent can only move 6". This is because your units lack your own god-like knowledge that there are no enemies around. It is perfectly fine to measure a unit's move in one direction, and then change your mind and decide to move it somewhere else (even the opposite way entirely!) or decide not to move it at all.

## MODELS IN THE WAY

A model may not move into or through the space occupied by another model (which is represented by its base or by its hull) or through a gap between friendly models that is smaller than its own base (or hull) size. A model cannot move so that it touches an enemy model during the Movement and Shooting phases – this is only possible in an assault during the Assault phase. To keep this distinction clear, a model may not move within 1" of an enemy model unless assaulting.

## DIFFERENT MOVEMENT DISTANCES IN A UNIT

All of the models in a unit move at the speed of the slowest model.

## RANDOM AND COMPULSORY MOVEMENT

Sometimes, a unit may have to move a random distance instead of the usual 6" or be forced to move in a certain way (directly towards the closest enemy, for example). Such situations are discussed later.

## TURNING AND FACING

As you move the models in a unit, they can turn to face in any direction, without affecting the distance they are able to cover. Infantry models can also be turned to face their targets in the Shooting phase, so don't worry about which way they are pointing at the end of their Movement phase (although dramatically facing off against their foes is traditional).

## MOVING AND CLOSE COMBAT

Units already locked in close combat with the enemy may not move during the Movement phase.



## Moving models

When moving models, it's a common mistake to measure the distance and then place the model on the far side of the tape measure. This is incorrect, as it adds the entire length of the model's base to the distance moved. While this is not a huge error on a 25mm base, it makes a considerable difference on a vehicle, in which case it might almost double the move (as shown below). The two diagrams here show examples of the right and wrong way to move your models.

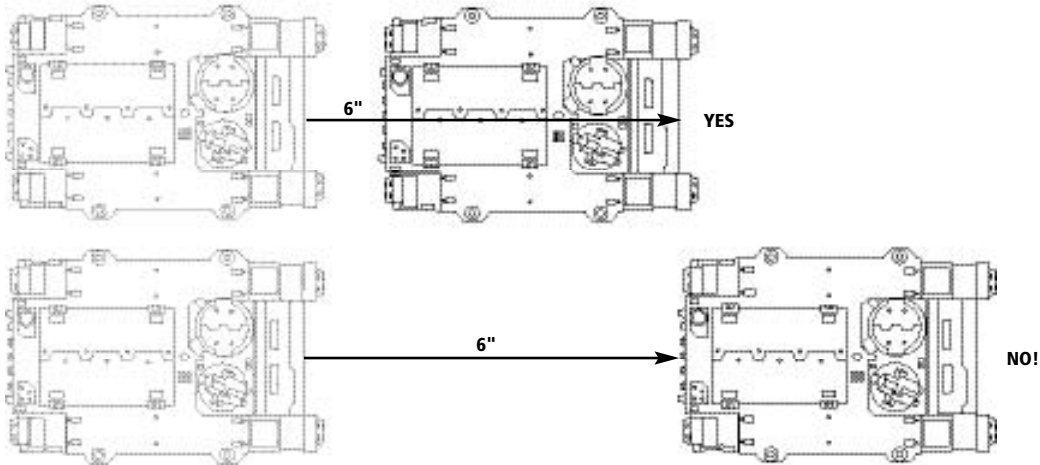
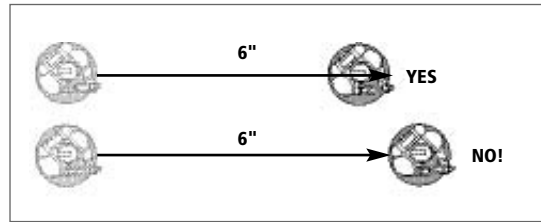

## UNIT COHERENCY

When you are moving a unit, the individual models in it can each move up to their maximum movement distance – but remember that units have to stick together, otherwise individual models become scattered as the unit loses its cohesion as a fighting force. So, once a unit has finished moving, the models in it must form an imaginary chain where the distance between one model and the next is no more than 2". We call this 'unit coherency'.

During the course of a game, it's possible a unit will get broken up and lose unit coherency, usually because it takes casualties. If this happens, the models in the unit must be moved in such a way that they restore coherency in their next Movement phase. If the unit cannot move for some reason in its next turn (because they are pinned down by a barrage or sniper fire, for example), then they must move to restore unit coherency as soon as they have the opportunity.

**"Follow me if I advance.**

**Kill me if I retreat.**

**Avenge me if I die."**

Warmaster Solon

### Unit Coherency

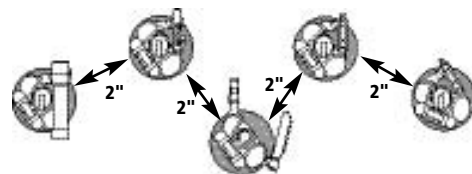

*In coherency.*

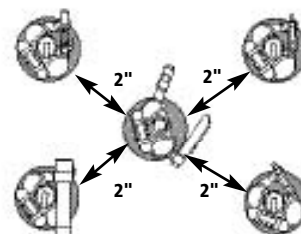

*In coherency.*

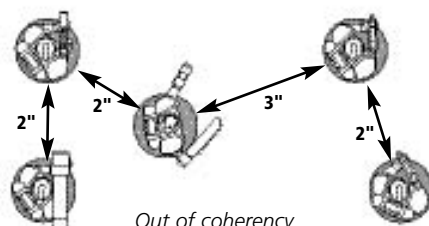

*Out of coherency.*

## TERRAIN

The galaxy is a vast place with millions of different warzones: ice worlds, desert worlds, hive worlds, feral worlds and many other exotic types of battlefield – if you can imagine it, then it probably exists somewhere. The terrain covering these worlds can vary from broad, empty plains to sky-scraping towers of plexiglass and plasteel, from verdant jungles to barren moonscapes or baking hot deserts. How to represent terrain on the battlefield is discussed later (see page 88).

For now, we're going to discuss terrain only in terms of how infantry move through it.

### TERRAIN TYPES

Terrain provides useful cover from enemy fire, but can also impede the movement of your units. Troops can be slowed by pushing through or climbing over barriers and obstructions. There are three general classes of terrain: clear, difficult and impassable.

- **Clear terrain** can be moved across without any penalty, and generally covers most of the battlefield.
- **Difficult terrain** slows down models wishing to move through it, and can sometimes be dangerous to models passing through it.
- **Impassable terrain** cannot be moved across or into.

### Guidelines on categorising terrain

It is a relatively simple matter to classify terrain within these four categories, and it is important that you and your opponent agree what class of terrain each feature falls into before starting your game.

- Clear terrain includes open areas, such as fields, moorland, grass, deserts, ash wastes and gentle hills. This could be embellished with the odd tree, shrub or cactus (or alien equivalents) for visual appeal.
- Difficult terrain includes areas of rubble, jungles, woods, ruins, brush and scrub, rocky outcrops, boggy ground, low walls, hedges, fences, razor wire, barricades, steep hills, streams and other shallow water (as well as terrain features that combine several of these types, such as a ruin surrounded by woods). If the terrain feature includes hazards, such as booby traps, carnivorous plants, toxic vents, erupting geysers and the like, then it may be additionally categorised as both difficult and dangerous terrain.
- Impassable terrain includes deep water, lava flows, steep rocky cliffs and buildings that models cannot enter, as agreed with your opponent. Remember that other models, friends and enemies, also count as impassable terrain.
- Buildings that models can enter, like bunkers, bastions and other fortifications.

You will notice that buildings appear in more than one category. Buildings will be treated in detail in their own section, on page 77.

### AREA TERRAIN

Sometimes a terrain feature has clearly defined edges, such as a crater, a stream or an intact building. Other times, however, this might be slightly less clear, as in the case of marshes, woods, ruins and other types of rough ground. In reality a wood might be a tangled, overgrown mass of foliage, without a clear edge. If it is represented like this on your tabletop, then it will be very difficult to stand models on it, and it would be difficult to decide if the models are inside or outside it.

For the clarity of the game it is important to be able to tell where the boundary of the terrain feature is, as these pieces normally count as difficult terrain. This is where we need to introduce the concept of 'area terrain'. You can show the boundary of a piece of area terrain by using a flat baseboard, an outline of lichen or sand, or by painting a slightly different colour on your gaming board. Trees, rocks, ruins, or whatever is appropriate for the kind of area terrain you are representing, are usually placed within the boundary of the area terrain's base.

When moving models into this area, you may temporarily remove the rocks, trees, etc. (if they are not glued in place!) to make moving the models easier. Remember, however, to put them back where they originally were (or as close as possible!) after you finish moving, as they may affect the line of sight of models shooting through that area terrain.

You should discuss all such terrain features with your opponent before the game and agree exactly what everything counts as and where boundaries of terrain features lie. When the game is underway, it will be harder to discuss it quite so impartially.

#### **Wobbly Model Syndrome**

*Sometimes you may find that a particular piece of terrain makes it hard to put a model exactly where you want. If you delicately balance it in place, it is very likely to fall as soon as somebody nudges the table, leaving your beautifully painted miniature chipped or even broken. In cases like this we find it is perfectly acceptable to leave the model in a safer position, as long as both players have agreed and know its 'actual' location. If later on your enemy is considering shooting at the model, you will have to hold it back in the proper place so he can check line of sight.*

*Of course if you prefer things to be completely clear and exact, then stick to simple, flat terrain!*

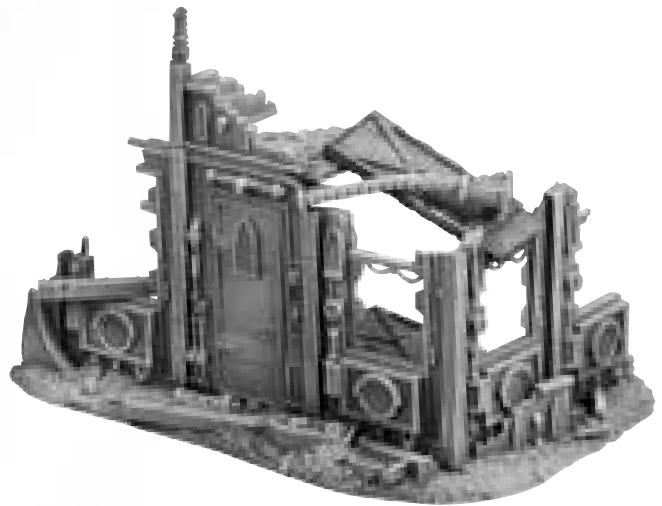

*Both the wood and the ruin are examples of area terrain. As you can see, their bases clearly define their extent on the table top. Both these features are also difficult terrain, and players may agree that the ruin counts as dangerous too.*

## MOVING THROUGH DIFFICULT TERRAIN

During a game of Warhammer 40,000, there can be two slightly different cases of units moving through difficult terrain.

If any of the models in a unit start their move inside difficult terrain, the unit is affected by the terrain and must take a difficult terrain test. Roll two D6 and select the highest – this is the maximum distance in inches that all of the models in the unit (not just the ones in difficult terrain!) may move.

If a unit starts its move outside difficult terrain, the player must declare if he wants his unit to try to enter difficult terrain as part of their move. If he chooses not to, the unit moves as normal but may not enter difficult terrain. If he chooses that they will do so, the unit must take a difficult terrain test as described above. Even if the distance rolled is too short for any of the models to reach the difficult terrain, the unit is still slowed down as described above. We assume that they are cautiously approaching the terrain, using their sensors to ascertain that no enemy is hiding in there.

If you take the difficult terrain test, you are never compelled to move the models, as you may not have rolled high enough to make it worth moving at all. However, if you roll the dice, the unit is still considered to have moved for the purposes of firing, as detailed later in the Shooting rules.

Note that as part of their move through difficult terrain, models may move through walls, closed doors and windows, and all sort of similarly solid obstacles, unless the players have agreed that a certain wall or obstacle is impassable. This represents the warriors bashing their way past locked doors and windows, using explosives or their weapons to create breaches in light walls, climbing over low obstacles and so on.

## DANGEROUS TERRAIN

As mentioned previously, some terrain features will be dangerous to move through. This is represented by the dangerous terrain test. Roll a D6 for every model that has entered, left or moved through one or more areas of dangerous terrain during its move. On the roll of a 1, the model suffers a wound, with no armour or cover saves allowed (wounds and saves are explained in the next section).

## IMPASSABLE TERRAIN

Models may not be placed in impassable terrain unless the models concerned have a special rule in their profile granting them an exception (like being able to fly above the terrain) or both players agree to it.

---

**Blessed is the mind too small for doubt.**

---

# THE SHOOTING PHASE

**As the two armies engage each other, guns thunder ceaselessly with plasma blasts, shells and shrapnel raining down on both sides.**

In a Warhammer 40,000 battle, we split up the firing so that each player's force fires during the Shooting phase of his own turn. During the Shooting phase, any and all of your units may fire. You can choose any order for your units to shoot, but you must complete all the firing by one unit before you move on to the next.

Normally each model in a firing unit can fire a single weapon. Some models, including vehicles, may be able to fire more than one weapon, as detailed later.

The shooting process can be summarised in six steps, as described below.

## THE SHOOTING SEQUENCE

- 1 Check line of sight & pick a target.** Pick one of your units, check its line of sight and choose a target for it. All models in the unit that can see at least one enemy model in the target unit may open fire.
- 2 Check range.** At least one target model must be within range of the weaponry of your firing models.
- 3 Roll to hit.** Roll a D6 for each shot fired. The model's BS determines what score they must equal or beat to hit their target.
- 4 Roll to wound.** For each shot that hits, roll again to see if it wounds the target. The score needed is determined by comparing the Strength of the firing weapons with the Toughness of the target.
- 5 Take saving throws.** Each wound suffered may be cancelled by making a saving throw. Saving throws usually derive from the armour worn by each model, from being in cover, or some other piece of wargear or ability. If the target unit includes different types of models, you will first have to allocate the wounds onto specific models.
- 6 Remove casualties.** The target unit suffers casualties for any wounds that have not been saved.

Once you've completed this shooting sequence with one of your units, select another and repeat the sequence. Once you have completed steps 1 to 6 for each unit in your army, carry on to the Assault phase.

The rules for the Shooting phase end with details of the different categories of ranged weapon available to warriors in the 41st Millennium.

## DISALLOWED SHOOTING

Certain situations prevent a unit from firing. The most common are:

- Units that are locked in close combat with the foe.
- Units that are running (see overleaf).
- Units that have gone to ground because of enemy fire in the previous turn (see page 24).

In addition to the above, certain types of weapons can only be fired if the unit did not move in the same turn. However, this will only prevent models with that weapon from shooting – not the whole unit.

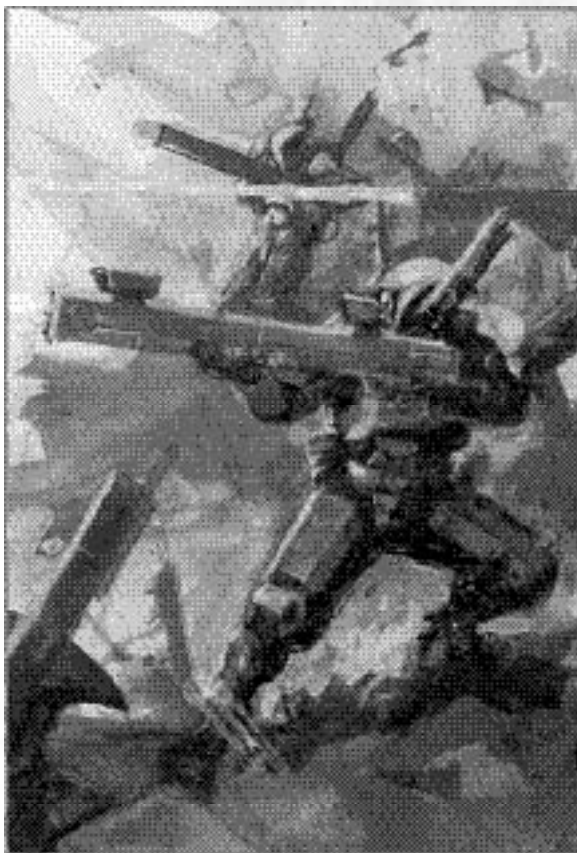

## RUN!

At times, warriors may have to quickly redeploy, literally running from cover to cover or simply concentrating on movement and giving up their chance to shoot. In their Shooting phase, units may choose to run instead of firing, immediately moving D6" (we find that this is a popular choice for units

that have no ranged weaponry or no target!). Running movement is not affected by difficult terrain – it is always simply D6" – but models running through dangerous terrain must test as normal. Units that run in the Shooting phase cannot assault in the following Assault phase.

## CHECK LINE OF SIGHT & PICK A TARGET

A firing unit can choose a single enemy unit that is not locked in combat as its target, and may not split its fire among different targets. In order to select an enemy unit as a target, at least one model in the firing unit must have line of sight to at least one model in the target unit. If no models have line of sight then a different target must be chosen.

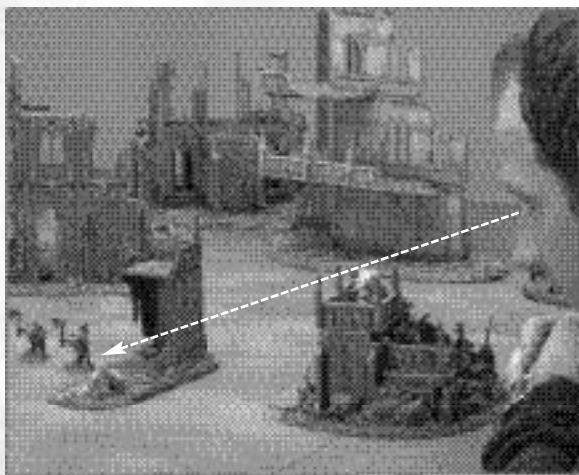

The player is checking the Space Marine's line of sight by looking from behind the firer's head to the body of the target model.

### Line of Sight

Warhammer 40,000 uses what we call 'true line of sight' for shooting attacks. This means that you take the positions of models and terrain at face value, and simply look to see if your warriors have a view to their targets. This is different to other, more abstract systems where terrain is assigned a height value and you have to calculate what warriors can see. We have chosen true line of sight because it makes the game feel much more cinematic and 'real'. There's nothing quite like getting a 'model's eye view' to bring the game to life. Of course, this method does mean that occasionally there are border-line cases when it is quite hard to decide if a model can see a target or not, but sporting players will always be generous and give their opponent the benefit of the doubt.

Line of sight literally represents your warriors' view of the enemy – they must be able to see their foe through, under or over the tangle of terrain and other fighters on the battlefield. Of course your models are made of plastic or metal, so they can't tell you what they can see – you'll have to work it out for them. In some cases it will be obvious – if there is a hill or a tank blocking their view, the enemy may be blatantly out of sight. In other cases two units will be plainly in view of each other, as there is nothing at all in the way. Many times however, it will be more difficult to tell if line of sight is blocked or not, so players will have to stoop over the table for a 'model's eye view'. This means getting down to the level of your warriors, taking in the view from behind the firing models to 'see what they can see'. You will find that you can spot lurking enemies through the windows of a ruined building, and that high vantage points become very useful for the increased line of sight that they offer.

Line of sight must be traced from the eyes of the firing model to any part of the body of at least one of the models in the target unit (for 'body' we mean its head, torso, legs and arms). Sometimes, all that may be visible of a model is a weapon, an antenna, a banner or some other ornament he is wearing or carrying (including its wings and tail, even though they are technically part of its body). In these cases, the model is not visible. These rules are intended to ensure that models don't get penalised for having impressive standards, blades, guns, majestic wings, etc.

### OWN UNIT

There is one important exception to the rules for line of sight. Firing models can always draw line of sight through members of their own unit (just as if they were not there), as in reality they would take up firing positions to maximise their own squad's firepower.

### WHICH MODELS CAN FIRE?

All models in the firing unit that have line of sight to at least one model in the target unit can fire.

A player may choose not to fire with certain models if he prefers (as some models may have one-shot weapons, for example). This must be declared before checking range, as all of the models in the unit fire at the same time.

## CHECK RANGE

All weapons have a maximum effective range, which is the furthest distance they can shoot. If a target is beyond this maximum range, the shot misses automatically. This is why you have to choose your target before measuring the range. Here are some examples of weapon ranges:

Weapon	Maximum Range
Laspistol	12"
Boltgun	24"
Autocannon	48"

When you're checking range, simply measure from each firer to the nearest visible model in the target unit.

Any model that is found to be out of range of all of the models he can see in the target unit misses automatically – his shots simply do not reach.

**"Victory does not always rest with the big guns; but if we rest in front of them, we shall be lost."**

Commander Argentius

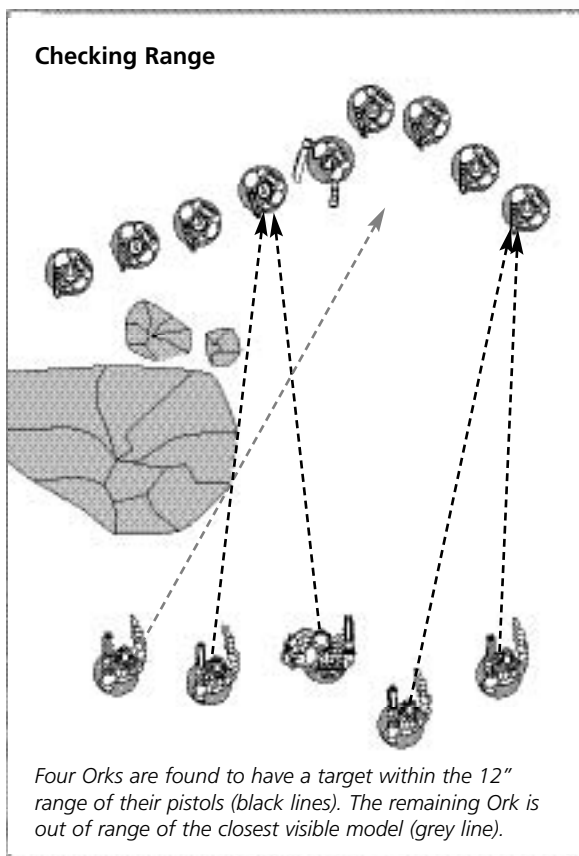

## MOVING & SHOOTING

Whether a unit has moved or not can make a big difference to its firing. If the warriors hold a position, take up firing stances and aim at their targets properly, some weapons can hit targets further away than if they are firing on the move. Other guns are so heavy that they can only be used if their firers halt completely to brace themselves or set up their weapons on the ground. This is explained in more detail in the Weapons section later, but for the time being it's enough to know that moving can make a difference to a unit's shooting.

The most important thing to remember is that the whole unit counts as moving if any of its models moved in the Movement phase.



## ROLL TO HIT

To determine if the firing models have hit their target, roll a D6 for each shot that is in range. Normally troopers will only get to fire one shot each. However, some creatures or weapons are capable of firing more than once, as we'll explain in more detail later. The dice score needed to hit will depend on how accurate the firers are, as shown by their Ballistic Skill characteristic (or BS). The chart below shows the minimum D6 roll needed to score a hit.

Firer's BS	1	2	3	4	5
Score needed to hit	6	5+	4+	3+	2+

For example, if the shooters are a unit of five Space Marines with a BS of 4, you would roll five dice and each roll of a 3 or more would score a hit.

To Hit rolls are easy to remember if you just subtract the BS of the shooter from 7. This will give you the number you need; e.g. a model with a BS of 2 needs to roll a 5 or more (7-2=5).

Note that the minimum roll needed to hit is always at least 2. When rolling to hit, there is no such thing as an automatic hit and a roll of a 1 always misses.

**The reward for treachery is retribution**

## BALLISTIC SKILL OF 6 OR BETTER

Very rarely a model may have a BS of 6 or even more. If a model has a BS of 6 or higher, it gains a re-roll whenever it rolls a 1 to hit with ranged attacks. The second roll has normally a lower chance of hitting, and the number needed is given in the chart below in italics after the slash.

Firer's BS	6	7	8	9	10
Score needed to hit	2/6	2/5	2/4	2/3	2/2

For example, a model with BS 7 fires a shot with its pistol. It rolls a 1, missing, but thanks to its exceptional BS it can re-roll the dice. This time, however it won't hit on a 2, but rather on a 5.

If a model has a special rule that already confers it a re-roll to hit (like a master-crafted weapon, for example), then that re-roll takes precedence and the chart above is not used. Instead the chances to hit on the re-roll are the same as the first shot, depending of the firer's BS. Remember a dice can only ever be re-rolled once!

## FAST ROLLING WITH DIFFERENT WEAPONS

When a unit fires, all of its weapons are fired simultaneously, so you should ideally roll all of its To Hit dice together. Sometimes there will be different weapons firing, or firers with different BS in the same unit, in which case we find it easiest to use different coloured dice, so that those shots can be picked out. For example, a squad may include several bolters, a plasma gun and a lascannon, in which case you could use white dice for bolter shots, a green dice for the plasma gun and a red dice for the lascannon. Alternatively, you can simply make separate dice rolls for different weapons or shooters, as long as it is clear which dice rolls represent which shots.

---

**"Let the Orks come by the thousand, or by the tens of thousands; we shall be ready for them. This world is the Emperor's, not theirs, and we shall wash it clean with their blood."**

Pedro Kantor, Master of the Crimson Fists

---



## ROLL TO WOUND

Hitting your target is not always enough to put it out of action. The shot might result in nothing more than a superficial graze or flesh wound.

To decide if a hit causes a telling wound, compare the weapon's Strength characteristic with the target's Toughness characteristic. Each weapon has its own Strength value, given in the description of the weapon. Here are some examples of different weapons and their Strength characteristics.

Weapon	Strength
Boltgun	4
Plasma gun	7
Lascannon	9

Consult the chart below, and cross-reference the weapon's Strength (S) with the target's Toughness (T). The number indicated is the minimum score on a D6 needed to convert the hit into a wound. Just like rolling To Hit, roll the dice together and, once again, use different coloured dice to pick out weapons with different Strengths or roll them separately.

*Example: a Space Marine with a boltgun shoots at an Ork and hits him. A boltgun has a Strength of 4 and the Ork has a Toughness of 4. Referring to the chart, a score of 4 or more is needed to convert the hit into damage. If the roll is 4 or more, the Ork takes a wound.*

## MULTIPLE TOUGHNESS VALUES

Quite rarely, a unit will contain models with differing Toughness characteristics.

To keep things simple, roll to wound using the Toughness characteristic that is in the majority in the target unit. If no majority exists, use the highest value in the unit.

*For example, in a unit containing Gretchin and an Ork Runtherd, the Gretchin's Toughness of 3 is used for all models. Only if the unit is reduced to two models (the Runtherd and a single Gretchin) at the moment when the enemies roll to wound, must they roll against the Ork's Toughness of 4 for both models.*

### Speed rolling

*You'll soon get used to the system of rolling to hit, to wound and to save. We find it is quickest to pick up the dice that rolled a successful result at each stage and roll them again.*

### Cocked dice

*Occasionally a dice will end up in a crevice in your terrain or in the crack between two sections of board and doesn't lie flat. We call this a 'cocked dice'. Some players use a house rule that if any dice is not completely flat on the table, it must be re-rolled. More common is for players to re-roll the dice only if they can't be sure of the result. Of course, if your gaming surface is very textured and results in a lot of cocked dice (or simply if you prefer a tidy battlefield) you can make all your rolls in a tray or box lid.*

### Dice on the floor

*It is generally accepted that if a dice ends up on the floor, it doesn't count – so you don't need to shine a torch under the sofa to find out if you made your save or not! Most gamers agree that such dice can be rolled again. However, one player we know has a house rule that if your dice misses the table, you have failed the roll – after all, if you can't hit a huge table with a tiny dice, then what chance have your warriors got!*

## TO WOUND CHART

		Toughness									
		1	2	3	4	5	6	7	8	9	10
Strength	1	4+	5+	6+	6+	N	N	N	N	N	N
	2	3+	4+	5+	6+	6+	N	N	N	N	N
	3	2+	3+	4+	5+	6+	6+	N	N	N	N
	4	2+	2+	3+	4+	5+	6+	6+	N	N	N
	5	2+	2+	2+	3+	4+	5+	6+	6+	N	N
	6	2+	2+	2+	2+	3+	4+	5+	6+	6+	N
	7	2+	2+	2+	2+	2+	3+	4+	5+	6+	6+
	8	2+	2+	2+	2+	2+	2+	3+	4+	5+	6+
	9	2+	2+	2+	2+	2+	2+	2+	3+	4+	5+
	10	2+	2+	2+	2+	2+	2+	2+	2+	3+	4+

*Note that N on the chart means the hit has no effect. A target with the Toughness indicated cannot be harmed by a hit of such puny Strength. Also note that a roll of 1 never scores a Wound, regardless of its Strength.*

## TAKE SAVING THROWS

Before he removes any models as casualties, the owning player can test to see whether his troops avoid the damage by making a saving throw. This could be because of the target's armour, some other protective device or ability, or intervening models or terrain.

If all the models in a unit are the same, and have a single Wound each, such as a squad of Eldar Rangers or Necron Warriors, then this is a very simple process. You roll all the saves for the unit in one go (as described below), and a model of your choice is removed as a casualty for each failure.

On the other hand, it is common for units to include models with different weapons or wargear and characters with different profiles (and sometimes even different armour). In these cases we need to know exactly who has been wounded, and this requires an extra step in the shooting process. The wounds the unit has suffered must be allocated onto specific models before saving throws are taken. This extra step is explained after the basic rules (see page 25).

## ARMOUR SAVES

Most troops wear some sort of protective clothing or armour, even if it's only a helmet! Some creatures may have a form of natural protection, such as a chitinous exo-skeleton or thick bony plates. If a model has a Sv value of 6 or better on its profile, it is allowed a further dice roll to see if the armour stops it being wounded. This is called an armour saving throw.

Roll a D6 for each wound the model has suffered from incoming fire and compare the results to the model's Sv characteristic. If the dice result is equal to or higher than the model's Sv value, the wound is stopped. If the result is lower than the Sv value, the armour fails to protect its wearer and the model suffers a wound. This means that, differently from other characteristics, a Sv value is better if it has a lower number.

The following table shows how the minimum D6 score required varies between three types of armour:

Armour Type	Sv
Ork armour	6
Imperial Guard flak armour	5
Space Marine power armour	3

*Example: a Space Marine wearing power armour is hit and wounded. The Space Marine is entitled to a saving throw of 3, so a D6 is rolled resulting in a score of 5. The damage is therefore saved, and the model is unharmed – the shot bounces off his power armour.*

### Armour piercing weapons

Some powerful weapons are quite capable of punching through even the thickest types of armour. This is shown by a weapon having an Armour Piercing value,

usually referred to as AP. Nearly all weapons have an Armour Piercing value. Some sample AP ratings for different weapons are shown below:

Weapon	AP
Boltgun	5
Heavy bolter	4
Lascannon	2

The AP rating indicates the armour save the weapon can ignore – so lower means more powerful. A weapon shown as 'AP –' has no Armour Piercing value and will never disallow the target's armour save.

- If the weapon's Armour Piercing value is equal to or lower than the model's armour save then it is sufficiently powerful to punch straight through the armour and the target gets no armour save at all. The armour is ineffective against the shot.
- If the weapon's Armour Piercing value is higher than the armour, the target can take his save as normal.

*Example: a boltgun with an AP of 5 can pierce armour which has a Sv of 5+ or 6. A heavy bolter has an Armour Piercing rating of 4 so saves of 4+, 5+ or 6 are ignored. A lascannon with its AP of 2 ignores even the best armour it is possible to wear!*

## INVULNERABLE SAVES

Some warriors are protected by more than mere physical armour. They may be shielded by force fields, enwrapped by mystic energies or have an alien metabolism that can shrug off hits that would put holes in a battle tank. Models with wargear or abilities like these are allowed an invulnerable saving throw. Invulnerable saves are different to armour saves because they may always be taken whenever the model suffers a wound – the Armour Piercing value of attacking weapons has no effect. Even if a wound normally ignores all armour saves, an invulnerable saving throw may still be taken.

**“As our bodies are armoured with adamantium, our souls are protected with loyalty. As our bolters are charged with death for the Emperor's enemies, our thoughts are charged with wisdom. As our ranks advance, so does our devotion, for are we not Marines? Are we not the chosen of the Emperor, his loyal servants unto death?”**

Chaplain Fergas Nils

## COVER SAVES

A position in cover shields troops against flying debris and enemy shots, enabling them to get their heads down or crawl amongst the rocks and (hopefully) avoid harm. Because of this, units in or behind cover receive a cover saving throw. The great thing about cover saving throws is that they are not affected by the Armour Piercing value of the attacking weapon, so units in cover will normally get a saving throw regardless of what's firing at them.

### What counts as Cover?

Cover is basically anything that is hiding a target or protecting it from incoming shots. For example, a soft obstacle (like a hedge) that would hide soldiers behind it, but would not even slow down enemy shots, confers a 5+ save, purpose-built fortifications confer a 3+ save, most other things confer a 4+ save. More detail can be found in the Cover chart below. Before deploying their armies, it is a very good idea for players to go through all the terrain pieces on the battlefield quickly and agree what kind of cover each will offer.

## COVER CHART

Cover Type	Save
a) Razor wire, Wire mesh	6+
b) High Grass, Crops, Bushes Hedges, Fences	5+
c) Units (friends and enemies), Trenches, Gun pits, Tank traps, Emplacements, Sandbags, Barricades, Logs, Pipes, Crates, Barrels, Hill crests, Woods, Jungles, Wreckage, Craters, Rubble, Rocks, Ruins, Walls, Buildings, Wrecked vehicles	4+
d) Fortifications	3+

### When are models in Cover?

When any part of the target model's body (as defined on page 16) is obscured from the point of view of the firer, the target model is in cover. This is intentionally generous, and it represents the fact that the warrior, unlike the model, will be actively trying to take cover (as well as the smoke, explosions and flying debris that are mercifully absent from our tabletop battlefields).

Firers may of course shoot over intervening terrain if they are tall enough or high up on some terrain piece so that their line of sight is completely clear. As usual, check the firers' line of sight by taking a good look from behind their heads, and 'see what they see'.

### Intervening models

If a target is partially hidden from the firer's view by other models, it receives a 4+ cover save in the same way as if it was behind terrain.

This does not mean that intervening models literally stop the shots, but rather that they obscure the sight of the firers or otherwise spoil their aim. A successful cover save in this case might mean that the firer has not shot at all, missing the fleeting moment when the target was in its sights. This is because, in the case of intervening friends, the firer would be afraid of hitting his comrades; while in the case of intervening enemies, the firer is distracted by the more immediate threat.

Scenic rocks and other decorative elements that players might have placed on the base of their models are always ignored from the point of view of determining cover (you cannot take your cover with you!).

---

**"If all else fails: duck. As a defensive stratagem it's unreliable, but incredibly reassuring for a moment or two."**

---

Lord Corvis of Petrax



## Exceptions

In order to keep the game flowing at a faster pace, we have made a few exceptions to the cover rules given on the previous page, namely:

- **Own unit:** In the same way as they can trace line of sight through members of their own squad, models can always shoot, and be shot at, through members of their own unit without conferring or receiving a cover save.
- **Inside area terrain:** Target models whose bases are at least partially inside area terrain are in cover, regardless of the direction the shot is coming from. This represents their increased chance of diving into or behind a piece of covering terrain.
- **Firing through units or area terrain:** If a model fires through the gaps between some elements of area terrain (such as between two trees in a wood) or through the gaps between models in an intervening unit, the target is in cover, even if it is completely visible to the firer. Note that this does not apply if the shots go over the area terrain or unit rather than through it (see the photographic diagram below).
- **Firing out of area terrain:** Models that are inside area terrain firing out will position themselves with good fields of vision. Therefore they may fire through up to 2" of the area terrain they are occupying without that terrain conferring a cover save to the target. Remember, of course, that models still need to see their target in order to be able to shoot at all.
- **Firing over a barrier:** Models that are in base contact with a linear piece of terrain they can see over, such as a low wall, barricade, tank trap or a fence, can fire at enemies on the other side without the barrier getting in the way of their shots.

## Units partially in cover

Sometimes, a unit will only be partially in cover, with some of its models in cover and some not. In this case you must decide if the majority of the unit is in cover. Models that are completely out of sight are considered to be in cover for this purpose.

If half or more of the models in the target unit are in cover, then the entire unit is deemed to be in cover and all of its models may take cover saves.

If less than half of the models in the target unit are in cover, then the entire unit counts as exposed and none of its models may take cover saves.

Of course being in cover or not often depends on the position of the firer as well as the target. If only one model is shooting, it will be easy to tell how many models in the target unit are in cover from the firer's point of view. If multiple models are shooting, you will need to work out how many models are in cover from the point of view of the majority of the firing models that are in range. If the majority of the firers have a clear shot to the majority of the models in the target unit, the unit receives no save. Otherwise it does. This may sound complex, but you will find that in reality in most cases it is quite obvious if a unit is in cover or not.

In situations where it's not obvious whether a unit is in cover or not, the normal solution is to strictly apply the majority rule above, and count how many models are in cover from the point of view of each of the firing models in range. As this process might prove to be rather time-consuming, for a faster (albeit less precise) solution, the players may agree to treat these units as in cover, but with a cover save of one less than normal (for example a 5+ save if partially in cover behind a building or another unit, which normally would offer a 4+ save). See the diagrams opposite for examples of units partially in cover.

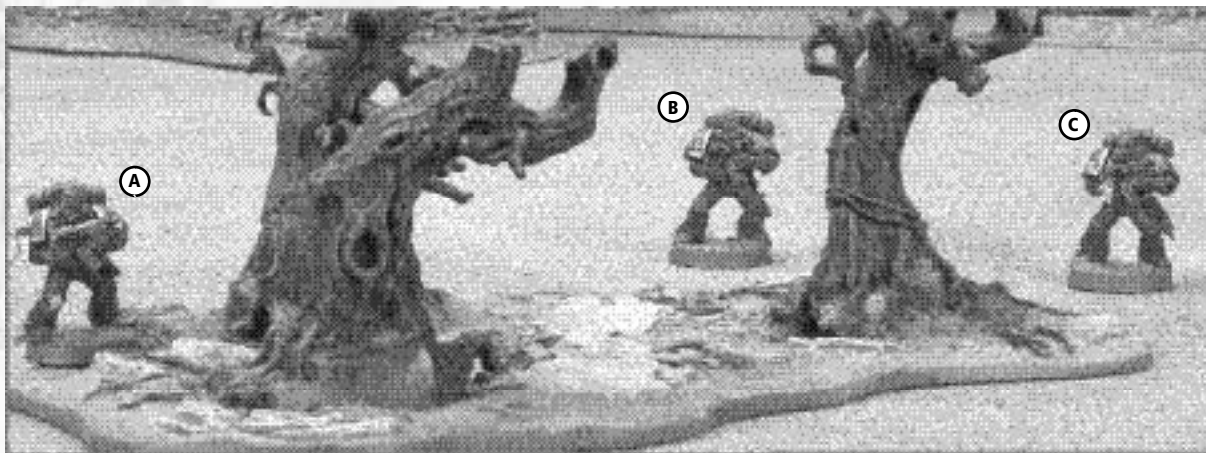

Model A is inside the area terrain and so is in cover. Model B is not inside the area terrain, but is between two elements of that area terrain (the same as if it was between two models of an intervening unit), so it is in cover. Model C is not in cover.

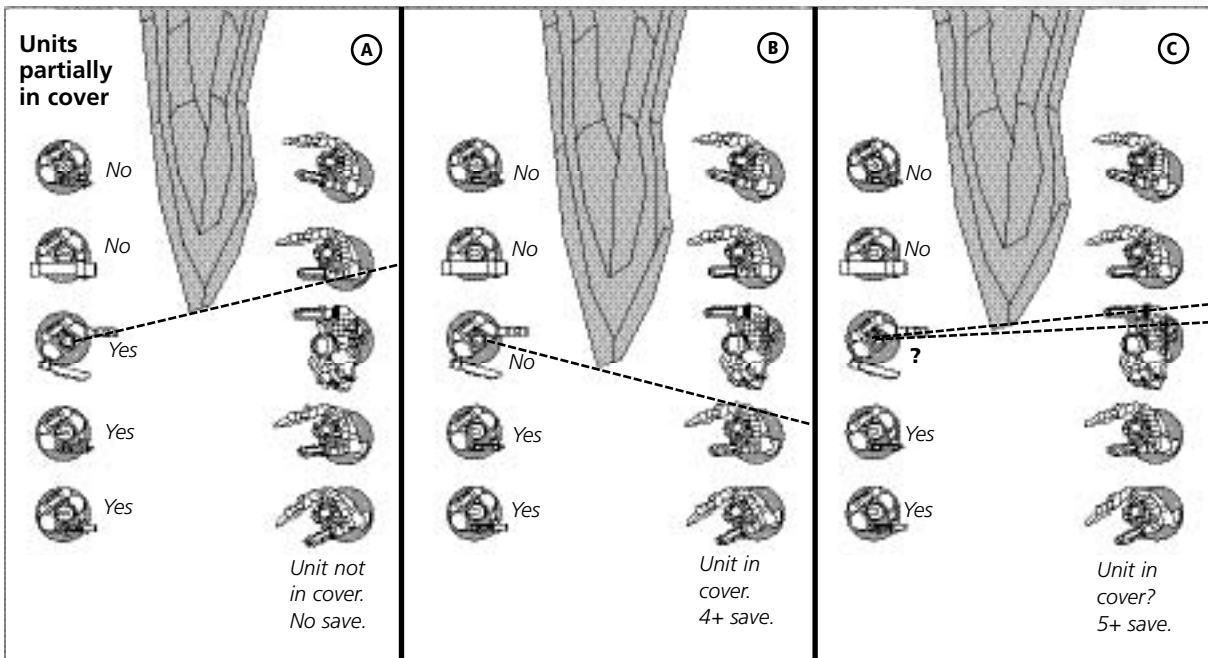

In case A, the majority of the firing Space Marine squad (i.e. three models out of five) have a clear shot to the majority of the models in the target unit (i.e. they have a clear shot to three or more Orks out of five). The Ork unit receives no cover save.

In case B, only two out of five Space Marines have a clear shot to the majority of the models in the target unit. The Ork unit receives a 4+ cover save (as rocks are in the way).

In case C, two Space Marines have a clear shot to the majority of the models in the target unit, and two Space Marines do not. The players check from the point of view of the model in the middle of the unit, and decide that it is practically impossible to be sure if he has a completely clear shot to at least three Orks. In this case, the players agree to give the Ork unit a cover save of 5+.

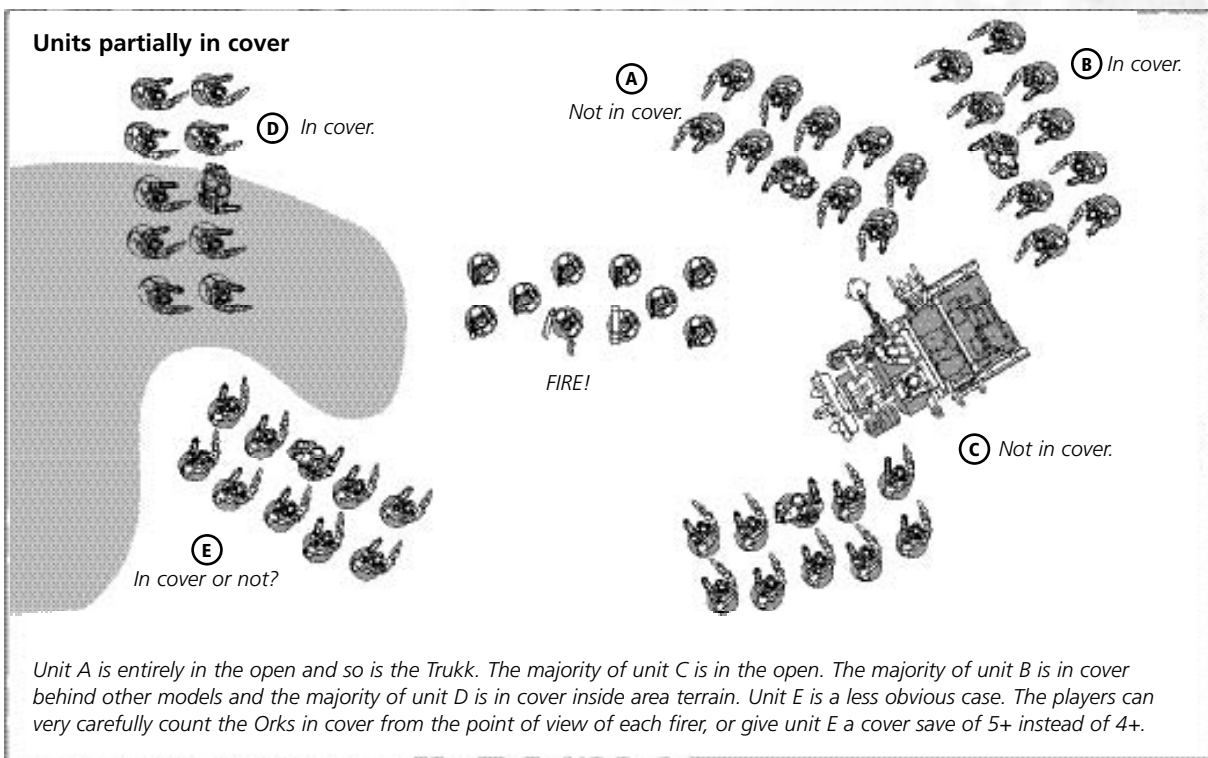

Unit A is entirely in the open and so is the Trukk. The majority of unit C is in the open. The majority of unit B is in cover behind other models and the majority of unit D is in cover inside area terrain. Unit E is a less obvious case. The players can very carefully count the Orks in cover from the point of view of each firer, or give unit E a cover save of 5+ instead of 4+.

## GOING TO GROUND

If warriors come under heavy fire, they may decide to keep their heads down and stay alive a little longer while they wait for reinforcements.

After the enemy has rolled to hit and wound against any of your units, but before you take any saves or remove any models, you can declare that the unit is going to ground. To represent this, place a suitable marker next to the unit (you may alternatively want to lay the models down). Models in a unit that has gone to ground immediately receive +1 to their cover saving throws. Units that are not currently in a position that would give them a cover save can still go to ground by diving to the floor (or some other evasion technique) and receive a 6+ cover save.



The drawback of going to ground is that the unit can do nothing until the end of its following turn. At the end of its following turn the unit returns to normal, the marker is removed and the unit is free to act as normal from then on.

Whilst it has gone to ground the unit may do nothing of its own volition, but will react normally if affected by enemy actions (for example, it will take Morale tests as normal). If the unit has to fall back, it will return to normal immediately. If assaulted, the unit will fight as usual, but gains no advantage for being in cover because they are not set to receive the enemy charge (see page 36).

**“He that may still fight, heal him.  
He that may fight no more,  
give him peace.  
He that is dead,  
take from him the Chapter’s due.”**

– Master of the Apothacarion Aslon Marr

## MODELS WITH MORE THAN ONE SAVE

Sometimes, a model will have a normal armour save and a separate invulnerable save – a good example is a Space Marine Chaplain who is protected by both power armour and a Rosarius-generated force field. As if this wasn’t enough the model might be in cover as well. In these cases, the model only ever gets to make one saving throw, but it has the advantage of always using the best available save.

For example, if the Chaplain described above was standing in a fortified building and was wounded by an AP3 weapon his power armour would be of no use, as the shot’s AP is equal to or lower than his armour save. The force field grants a 4+ invulnerable save. However, the fortified building grants a 3+ cover save. Neither of these saves is affected by the AP of the weapon so the Chaplain uses the cover save to give him the best chance of surviving.

If a unit can benefit from different types of cover, for example being behind a hedge (5+ cover save) and a low wall (4+), the unit uses the best cover save available (in this case 4+).

## MAXIMUM SAVE

Some models gain additional benefits from rules that may increase any of their saves by +1 or +2. However, no save (armour, cover or invulnerable) can ever be improved beyond 2+. A roll of 1 always fails.

## REMOVE CASUALTIES

For every model that fails its save, the unit suffers an unsaved wound. Of course this also includes wounds against which no save can be attempted, such as those from weapons with very high AP. Most models have a single Wound on their profile, in which case for each unsaved wound one model is immediately removed from the table as a casualty. As long as all the models in the unit have the same profile, special rules, weapons and wargear, the player who owns the unit can choose which of his models is removed.

Note that any model in the target unit can be hit, wounded and taken off as a casualty, even models that are completely out of sight or out of range of all of the firers. This may seem slightly strange, but it represents the fact that the real action on the battlefield is not as static as our models. In reality the warriors, both the firers and the targets, would be moving around and real bullets have a nasty habit of ricocheting or simply going through covering terrain!

Casualties are not necessarily dead – they may be merely knocked unconscious, too injured to carry on fighting or incapacitated in other some way. In any case, they are no longer fit to participate in the battle.

## COMPLEX UNITS

The rules for taking saving throws and removing casualties, as presented so far, assume that all the models in the target unit are identical in gaming terms. By this we mean they have the same profile of characteristics, the same special rules and the same weapons and wargear.

Of course many units include different models, and when this is the case an extra step is needed to determine which warriors have been hit by which weapons. This is worked out as follows:

Once the number of wounds caused by the firing unit has been determined, the player controlling the target unit must decide which models have been wounded, allocating the wounds to the warriors of their choice. Remember that any model in the unit can be wounded, not just those in range or in view.

The player must allocate one wound to each model in the target unit before he can allocate a second wound to the same model.

Once all models in the target unit have one wound allocated to them, the process is repeated and the player must allocate a second wound to all models in the target unit before he can allocate a third wound to a model, and so on, until all wounds from the firing unit have been allocated.

We find that the clearest way of doing this is to literally pick up the dice that have scored wounds and place them next to the models that they have wounded. It is still important to know which weapon has caused which wound, because they may negate the target's save, so sticking with the same coloured dice used when rolling to hit will really help.

## TAKING SAVING THROWS

Having allocated the wounds, all of the models in the unit that are identical in gaming terms take their saving throws at the same time, in one batch. Casualties can then be chosen by the owning player from amongst these identical models. If there is another group of identical models in the unit, the player then takes all of their saves in one batch, and so on.

Finally, the player rolls separately for each model that stands out in gaming terms. If one of these different models suffers an unsaved wound, then that specific model must be removed. Note that if a model carrying a different weapon to the rest of the unit is killed and removed, his squad-members are not allowed to pick up his gun. We can assume that he was the only one trained to use the weapon, or that the weapon itself has been damaged and is now useless.

The diagram below shows an example of how this process works. You'll find that it is quite intuitive once you have tried it a few times.

### Allocating wounds on complex units

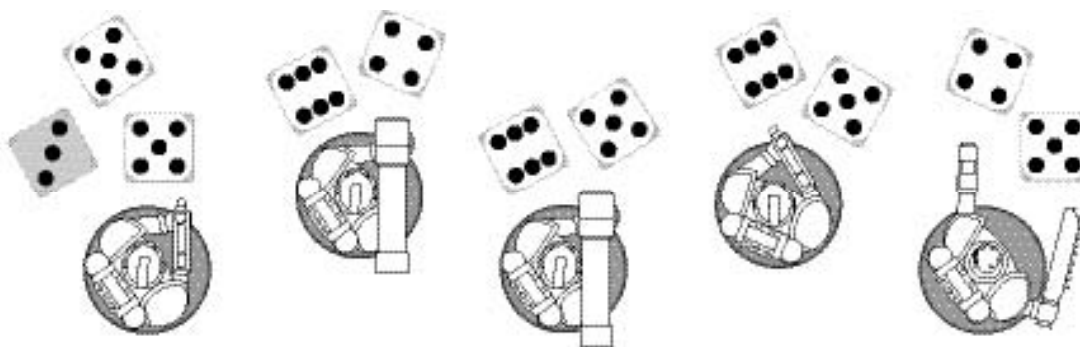

*This Space Marine Devastator combat squad consists of five models: two Space Marines armed with bolters, two armed with missile launchers and one Veteran Sergeant (who has a different profile and wargear from the rest of the squad). They are hit by a volley from a nearby enemy squad and suffer eleven wounds – ten wounds from weapons whose AP is not high enough to pierce their armour, and one from a weapon that can (e.g. an AP1 melta-gun). This amounts to two wounds per model and a single spare wound.*

*The player controlling the Space Marines picks up the dice that scored a wound and uses them to show how he is going to allocate the wounds (shown above). He allocates one normal wound, the melta-gun one (the grey dice) and*

*the spare wound on a Space Marine with a bolter, and then two normal wounds on every other model. He is trying to minimise the damage by allocating both the worst wound (the melta-gun's) and the spare wound on the same model.*

*He goes on to roll the four saves for the Space Marines with bolters in one go, failing two. He should remove three models (two unsaved wounds plus one wound with no armour save from the melta-gun), but as there are only two models in this group of identical models, he just removes them both. Then he rolls the four saves for the Space Marines with missile launchers in one go, failing one and removing one of the models. Finally he takes the two saves for the Veteran Sergeant, passing both.*

---

## MULTIPLE-WOUND MODELS

---

Especially tough and heroic individuals such as Space Marine commanders, or horrendous alien monstrosities such as Tyranid Hive Tyrants, can sustain more damage than ordinary troopers and keep on fighting. To show this, they have more than one Wound on their characteristic profile.

When such a multiple-wound model suffers an unsaved wound, it loses one Wound from its profile. Once the model has lost all of its Wounds, it is removed as a casualty (so a model with 3 Wounds would only be killed after it had been wounded three times). Keep track of how many wounds such models have suffered on a piece of scrap paper, or by placing a dice or marker next to them.

### INSTANT DEATH

Even though a creature might have multiple Wounds, there are plenty of weapons in the 41st Millennium that are powerful enough to kill it instantly. If a model suffers an unsaved wound from an attack that has a Strength value of double its Toughness value or greater, it is killed outright and removed as a casualty. It can be imagined that the creature is vapourised, burned to a pile of ash, blasted limb from limb or otherwise mortally slain in a suitably graphic fashion.

*Example: a Space Marine Captain is Toughness 4 and has 3 Wounds. Ordinarily, he could survive being wounded twice before being removed as a casualty on the third wound suffered. However, if he were to have the misfortune to be wounded by a krak missile (Strength 8 – normally used for knocking out battle tanks), he would become a casualty immediately because the missile's Strength is double his Toughness.*

Some models can gain improvements to their Toughness by using wargear items like bikes, Chaos Marks, etc. When it comes to instant death, such bonuses do not count (ie, riding a bike won't save you from being obliterated by a lascannon blast!). In these cases two values will be shown for the Toughness characteristic of the model, one of which is in brackets. Use the lowest value for working out instant death.

---

**BURN THE HERETIC!**

**KILL THE MUTANT!**

**PURGE THE UNCLEAN!**

---

## UNITS OF MULTIPLE-WOUND MODELS

Units consisting of models with multiple wounds on their profile, such as Tyranid Warriors and Ork Nobz, are quite rare. Working out how to allocate wounds and remove casualties from such units can be quite complex, so if you don't have any in your army, feel free not to finish reading this page!

If a unit consists entirely of models that are identical in gaming terms and have multiple wounds, then take all the saves for the unit in one go.

If the unit includes different models, first allocate the wounds suffered. Then take saves for identical models at the same time as normal.

Once you have determined the number of unsaved wounds suffered by a group of identical multiple-wound models, you must remove whole models as casualties where possible. Wounds may not be 'spread around' to avoid removing models. Track any excess wounds with a note or a marker as noted above. Multiple-wound models in the unit that are unique are rolled for individually and their unsaved wounds must be recorded separately.

*For example, let us examine a unit of four Ork Nobz, which have 2 Wounds each. Three of the Nobz are identical, while one has been upgraded with a better weapon. If the unit suffers nine wounds, the player must allocate two on each model, leaving a spare wound that he will allocate on a normal Nob. The player then takes seven saves for the three normal Nobz, failing three. He cannot put a single wound on each Nob, but must remove one model as well as recording that one normal Nob has suffered a wound. He then takes the two saves for the upgraded Nob and fails one, so he must record that the upgraded Nob has suffered a wound as well. The unit is then fired upon by another enemy and suffers a single wound. This will automatically kill the wounded Nob and cannot be allocated to the remaining healthy Nob.*

If amongst the unsaved wounds there are some that inflict instant death, the player must first, if possible, remove one unwounded model for each unsaved wound that causes instant death, and then proceed as normal (this is done for each group of identical multiple-wound models). This rule is designed to stop players avoiding single wounds by putting them on a model that has suffered instant death anyway.

*In the example above, if one of the three unsaved wounds on the normal Nobz caused instant death, the player would remove one unwounded Nob for that wound and then another normal Nob for the remaining two unsaved wounds. This would leave only one normal Nob and the upgraded Nob, which suffered one wound.*

# WEAPONS

By the 41st Millennium, warfare has spawned innumerable weapons, ranging in capability from the simple but efficient laspistol to the barely controllable energies of the plasma cannon. In this section we describe how characteristics and special rules reflect the differences between different weapons.

Every weapon has a profile that consists of several elements, for example:

Name	Maximum Range	Strength	Armour Piercing	Type
Boltgun	24"	4	5	Rapid Fire

## MAXIMUM RANGE

Ranges are all given in inches. If the weapon's range is given as 'Template' then the weapon fires using the teardrop-shaped Flamer template (the exact method is explained later).

## STRENGTH

As explained in the Shooting rules, when rolling to wound for shooting hits, you use the weapon's Strength rather than the firer's.

## ARMOUR PIERCING (AP)

This value shows how good the weapon is at punching through armour. The lower the number, the better the weapon is at piercing armour, cancelling the target's armour save. See the Shooting rules for more on armour saves and AP values.

## TYPE

All weapons are classified as either Rapid Fire, Pistol, Assault, Heavy or Ordnance. These rules (found overleaf) are a measure of the weapon's portability and affect the way it can be fired in relation to the model's movement during that turn's Movement phase.

Some weapons such as storm bolters and multi-lasers fire multiple shots. Where this is the case the number of shots a weapon fires is noted after its type. For example, a multi-laser fires three shots in each Shooting phase so its type is noted as Heavy 3.

Remember that the player can decide that any model in a firing unit is not going to fire its weapon. However, if a model does fire, it must do so at full effect and cannot reduce its weapon's firepower (for example, it cannot fire only two shots from its Heavy 3 weapon).

Some weapons may be able to fire in different ways, representing different power settings or different types of ammo. Where this is the case, there will be a separate line in the weapon's profile for each.

## ADDITIONAL CHARACTERISTICS

In addition to its type, a weapon may have some additional characteristics that define the way they work. These are added to the weapon type in the weapon's profile, and include characteristics like 'gets hot!' or 'blast'. A weapon may have any number of these characteristics in addition to its type.

---

**To a Space Marine, the boltgun is far more than a weapon; it is an instrument of Mankind's divinity, the bringer of death to his foes. Its howling blast is a prayer to the gods of battle.**

---

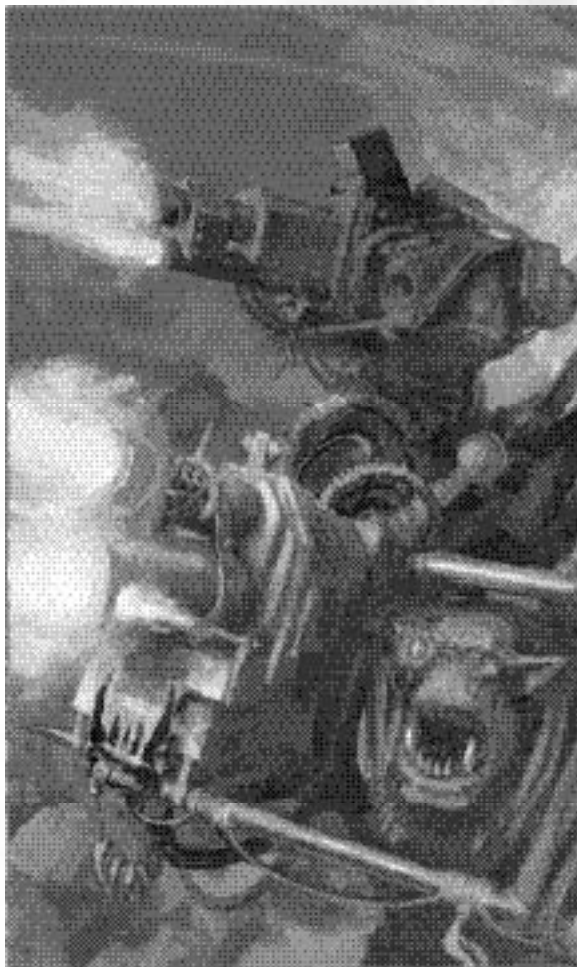

## WEAPON TYPES

### RAPID FIRE WEAPONS

Rapid fire weapons are very common and usually come in the form of semi-automatic rifles. Their versatility means they can be fired effectively 'from the hip' when a squad is advancing, spraying shots into the enemy whenever they present themselves, or instead used for aimed single shots against targets at greater distances.

Models armed with a rapid fire weapon can move and fire two shots at targets up to 12" away.

If the unit has not moved, models armed with rapid fire weapons may instead fire one shot at targets over 12" away, up to the weapons' maximum range. If such a unit is found to have firing models both within 12" of the target and further away, the firers within 12" will fire two shots, while those further away will fire one.

Models that shoot with rapid fire weapons in the Shooting phase cannot assault into close combat in the ensuing Assault phase.

Example	Range	S	AP	Type
Boltgun	24"	4	5	Rapid Fire

### ASSAULT WEAPONS

Assault weapons are fired by warriors as they move forward into the attack. They either fire so rapidly or are so indiscriminate that you don't have to do much more than point and shoot. For example, a flamer is a weapon that fires a fan-shaped gout of burning fuel, so it's just as accurate whether you are moving and firing or not. This means they are very good for moving and assaulting things... hence the name!

Assault weapons shoot the number of times indicated – whether you move or not and regardless of range.

Models carrying assault weapons can fire them in the Shooting phase and still assault into close combat in the Assault phase.

Example	Range	S	AP	Type
Big Shoota	36"	5	5	Assault 3

### Look to your wargear!

#### RAPID FIRE WEAPONS (firer may not assault)

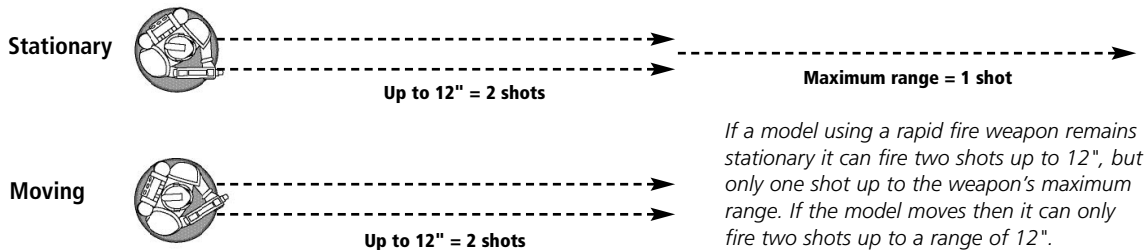

#### ASSAULT WEAPONS (firer may assault)

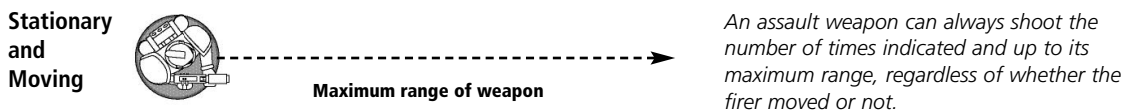

#### HEAVY WEAPONS (firer may not assault)

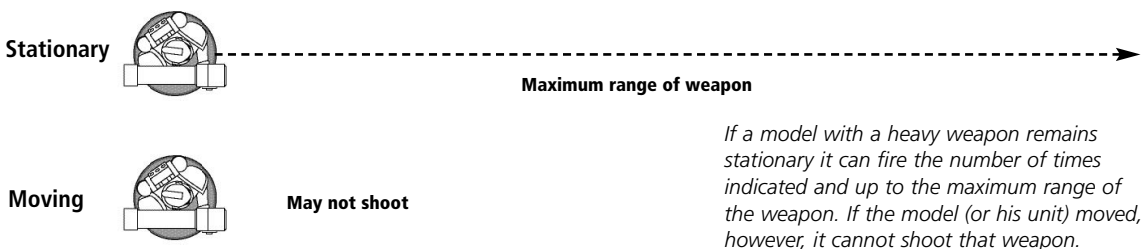

## HEAVY WEAPONS

These are heavy, man-portable weapons, such as missile launchers, or lighter weapons that require reloading between each shot, careful set-up or bracing against their considerable recoil.

If a unit moves then it cannot shoot heavy weapons – they either move or shoot, but not both. Remember that if any models move, their whole unit counts as having moved for that turn, and this will prevent models with heavy weapons from firing even if those specific models stayed still. When shooting, heavy weapons always fire the number of times indicated regardless of range. They are very good for laying down long range supporting fire or taking out tanks and monstrous creatures. Units that fire heavy weapons in the Shooting phase may not assault into close combat in the Assault phase.

Example	Range	S	AP	Type
Lascannon	48"	9	2	Heavy 1



## PISTOL WEAPONS

Pistol weapons are light enough to be carried and fired one-handed, but as they often have a less powerful charge, their range is limited. On the plus side, they are handy enough to allow a trooper to fight in close combat with a combination of a pistol and sword, axe or other close combat weapon.

All pistols are effectively Assault 1 weapons with a range of 12" (unless differently specified in their profile). In addition a pistol counts as a close combat weapon in the Assault phase.

Example	Range	S	AP	Type
Bolt Pistol	12"	4	5	Pistol

## ORDNANCE WEAPONS

Ordnance weapons are so huge and powerful that they cannot be physically carried by infantry, but must be mounted onto a vehicle or be built into the structure of a bunker or fortress. Their rules are covered in the Vehicles section on pages 58 and 60.

Example	Range	S	AP	Type
Battle Cannon	72"	8	3	Ordnance 1, Large Blast

## ADDITIONAL WEAPON CHARACTERISTICS

These extra weapon characteristics are represented by additional rules that are added to a weapon's type.

### TEMPLATE

These are particularly indiscriminate short-ranged devices, such as flame throwers, which affect a broad, cone-shaped area represented by a template (see diagram). They are indicated by having the word 'template' for their range instead of a number.

Instead of rolling to hit, simply place the template so that its narrow end is touching the base of the model firing it and the rest of the template covers as many models as possible in the target unit without touching any friendly models. Against vehicles, the template must be placed to cover as much of the vehicle as possible without also touching a friendly model. Any models fully or partially under the template are hit. Against vehicles, use the direction of the firer to determine which armour facing is attacked. Because template weapons bathe the area in burning fuel, cover saves are ignored when resolving wounds, even by models inside area terrain! Wounds inflicted by template weapons do not have to be allocated on the models actually covered by the template, but can be put onto any model in the unit.

Example	Range	S	AP	Type
Flamer	Template	4	5	Assault 1

### Multiple template weapons

If a unit is firing more than one template weapon, resolve each shot, one at a time, as described above, determining and recording how many hits are scored by each template. Finally, fire any other weapon in the unit, then add up all of the hits and roll to wound.

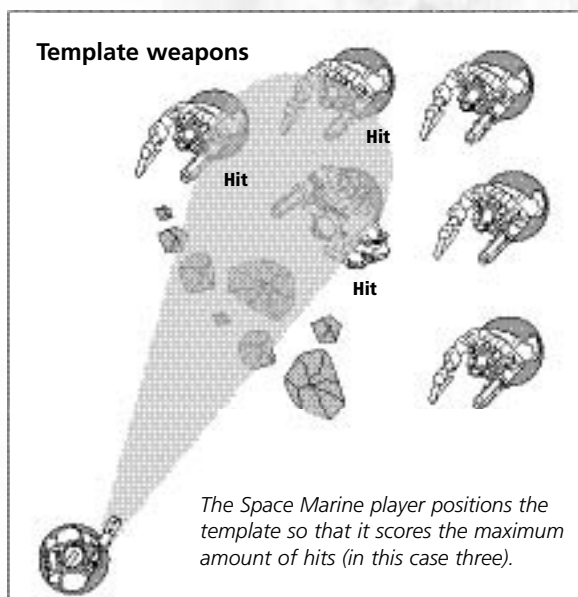

## BLAST

Blast weapons fire shells, missiles or bolts of energy that explode on impact.

When firing a blast weapon, models do not roll to hit, instead just pick one enemy model visible to the firer and place the blast marker (see diagram) with its hole over the base of the target model, or its hull if it is a vehicle. You may not place the marker so that the base or hull of any of your own models is even grazed by it.

Next, check if the shot has landed on target. If the hole at the centre of the marker is beyond the weapon's maximum range, the shot is an automatic miss and the marker is removed.

If the target is in range, the large area affected by the blast means it's going to be very hard to miss completely. Nonetheless, the shot may not land exactly where it was intended to. Roll the scatter dice and 2D6 to see where the shot lands. If the scatter dice rolls a hit symbol the shot lands on target (ignore the 2D6). If an arrow is rolled, the marker is shifted in the direction shown by the arrow a number of inches equal to the total of the 2D6 minus the firing model's BS (to a minimum of 0).

*For example, a BS4 Space Marine fires a frag missile and rolls an arrow result on the scatter dice. The 2D6 roll is a 7, so the blast is moved 3" (7 minus 4) in the direction indicated by the arrow.*

Note that it is possible, and absolutely fine, for a scattering shot to land beyond the weapon's range and line of sight, representing the chance of ricochets, the missile blasting through cover and other random chance. In these cases hits are worked out as normal, and can hit units out of range and sight (or even your own troops, or models locked in combat).

If the shot scatters so that the hole in the centre of the marker is beyond the table's edge, the shot is a complete miss and is discarded.

Once the final position of the blast marker has been determined, take a good look at the blast marker from above – all models whose bases are completely or partially covered by the blast marker are hit (as shown in the diagram).

Once the number of hits inflicted on the unit have been worked out, the firer rolls to wound as normal and then the controlling player may allocate these wounds on any model in the unit, not just the ones under the marker.

Example	Range	S	AP	Type
Missile	48"	4	6	Heavy 1,
Launcher (frag)				Blast

### Blast weapons

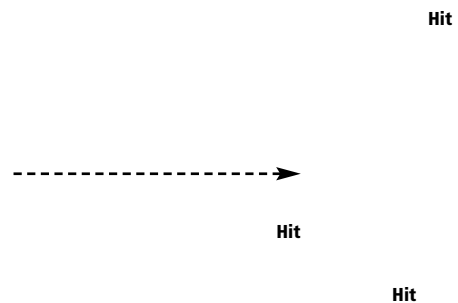

*The Space Marine player rolled a hit, so the blast marker is left in place, scoring three hits on the Ork unit.*

### Large blasts

There are two sizes of blast marker: the normal one (3" diameter) and the large one (5" diameter). This is clearly indicated in the weapon's profile. Both types of blast marker use exactly the same rules.

### Multiple blasts

If a unit is firing more than one blast weapon (for example, four Space Marine Devastators fire four frag missiles at an enemy), resolve each shot, one at the time, as described above, determining and recording how many hits are scored by each blast marker. Finally fire any other weapon in the unit, then add all of the hits together and roll to wound as normal.

### Blast weapons and re-rolls

If a model has the ability to re-roll its rolls to hit and chooses to do so after firing a blast weapon, the player must re-roll both the scatter dice and the 2D6.

### Scattering blast markers

*When rolling a scatter a dice to determine where a shot lands, you may have to move the blast marker several inches away from its intended position. If there are other potential targets nearby (and there often are!), it is quite normal for players to disagree on exactly where the blast marker should end up. This is because sitting at the opposite side of the table tends to give them a different point of view on the relative direction of the arrow on the scatter dice (and the wind always seems to nudge the blast marker slightly towards enemy models...).*

*To reduce this 'parallax error' we find that it's considerably more practical to roll the scatter dice as close as possible to the target point!*

## PINNING

Coming under fire without knowing where the shots are coming from is extremely shocking, making troopers throw themselves flat and hug cover as much as possible. Sniper fire and barrages are the most common causes of this.

If a unit other than a vehicle suffers any unsaved wounds from a pinning weapon, it must immediately take a Pinning test. This is a normal Leadership test.

If the unit fails the test, it is immediately forced to go to ground (as described on page 24). As the unit has already taken its saves, going to ground does not protect it against the fire of the pinning weapon that caused the test (or indeed of any other weapon fired by the same unit that phase) – it's too late!

As long as the tests are passed, a unit may be called upon to take multiple Pinning tests in a single turn, but if a unit has already gone to ground, no further Pinning tests are taken.

If the special rules of a unit specify that the unit can never be pinned, the unit always automatically passes Pinning tests. Such units can still choose to go to ground voluntarily.

## GETS HOT!

'Gets hot!' represents the penchant of certain unstable weapons for overloading and badly burning their user. Roll to hit as normal, except that you must roll to hit even if the target is found to be out of range. For each result of a 1 rolled on its to hit rolls, the firing model suffers a wound (normal saves apply). Because of their additional cooling systems, weapons on vehicles are not affected by this rule.

Example	Range	S	AP	Type
Plasma gun	24"	7	2	Rapid Fire, Gets Hot!

### Gets Hot! and blast weapons

Blast weapons do not roll to hit, so you must always roll a D6 before firing a Gets Hot! blast weapon to check if the weapon overheats. If you roll a 1, the weapon gets hot, it does not fire, and the firing model suffers a wound (normal saves apply). Otherwise the shot is resolved as normal.

### Gets Hot! and re-rolls

If a model has the ability to re-roll its rolls to hit (including because of BS 6+), it may re-roll Gets Hot! results of 1 without suffering a wound, unless the result of the re-roll is a 1 as well.

## TWIN-LINKED

Weapons are sometimes linked to fire together in order to increase the chances of scoring a hit through the crude expedient of blasting more shots at the target.

A set of twin-linked weapons count as a single weapon of that type, but to represent their fusillade of fire you may re-roll the dice to hit if you miss (including twin-linked blast weapons). In other words, twin-linked weapons don't get more shots than normal ones, but you get a better chance of hitting with them.

*Example: A Space Marine Land Raider is firing its twin-linked heavy bolters at an enemy. It gets three shots (as heavy bolters are Heavy 3) and may re-roll any to hit dice which don't score a 3 or higher (which is a hit for a Space Marine's BS of 4) because the weapons are twin-linked.*

### Twin-linked template weapons

Twin-linked template weapons are fired just like a single weapon, but they can re-roll the dice to wound. When fired against a vehicle, you may re-roll the armour penetration dice instead.

## RENDING

In the right circumstances, rending weapons have a chance of piercing any armour with a hail of shots, pinpoint accuracy or diamond-hard ammunition.

Any roll to wound of 6 with a rending weapon automatically causes a wound, regardless of the target's Toughness, and counts as AP2. Against vehicles, an armour penetration roll of 6 allows a further D3 to be rolled, with the result added to the total score.

Example	Range	S	AP	Type
Assault cannon	24"	6	4	Heavy 4, Rending

## SNIPER

These deadly weapons can be used to pick out a target's weak or vulnerable points.

Sniper hits wound on a roll of 4+, regardless of the victim's Toughness. In addition, all sniper weapons are also rending and pinning weapons (see above).

Against vehicles, sniper weapons count as Strength 3, which, combined with the rending rule, represents their chances of successfully hitting exposed crew, vision ports, fuel or ammo storage, etc.

Example	Range	S	AP	Type
Sniper rifle	36"	X	6	Heavy 1, Sniper

## BARRAGE

Certain weapons launch their shells high up into the air so that they plunge down upon their target, passing over any intervening cover en route and even striking targets that are out of sight.

Note that in older Codex books barrage weapons were identified by having a G (guess) before their range (e.g. Range: G48"). This is the same as having the word 'barrage' under their Type.

All barrage weapons use blast markers and consequently use the rules for blast weapons, with the following exceptions:

- To determine if a unit wounded by a barrage weapon is allowed a cover save, always assume the shot is coming from the centre of the marker, instead of from the firing model. Remember that models in area terrain get their cover save regardless of the direction the shot is coming from.
- Some barrage weapons have a minimum range as well as a maximum range (e.g. Range: 12" - 48"). If the centre of the marker is placed by the firer within the minimum range (before rolling for scatter), the shot misses automatically and is removed.
- Death raining from the sky is a truly terrifying experience, therefore all barrage weapons are pinning weapons as well (see Pinning).
- Barrage weapons can fire at a target they cannot see, but if they do this, the BS of the firer makes no difference and the blast marker scatters a full 2D6" if an arrow is rolled on the scatter dice.

Example	Range	S	AP	Type
Lobba	48"	5	5	Heavy 1, Blast, Barrage

### Multiple barrages

If a unit has more than one barrage weapon, they are all fired together in a salvo, as follows:

First place the blast marker for the weapon in the firing unit that is closest to the target. If the target is in range, roll for any scatter as described above.

Once the first marker is placed, roll a scatter dice for each other barrage weapon fired by the unit. If an arrow is rolled, place the marker in the direction indicated so that it is adjacent and touching the edge of the first marker placed (as shown in the diagram). If a hit is rolled, the firing player places the marker so that it touches any part of any marker in the salvo that has already been placed. Note that it is perfectly fine if, through this process, some markers are placed overlapping one another.

Once all of the markers are in place, work out the number of hits scored for each blast marker as usual for blast weapons and then roll to wound as normal.

### Multiple barrage weapons

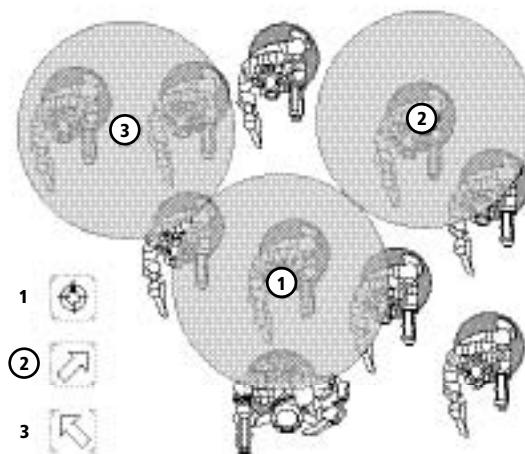

The original marker (1) scores a hit and does not scatter, while arrows are rolled for the second (2) and third (3) markers, which are placed accordingly. The number of hits scored is worked out separately for each marker, and in this case the salvo scores a total of nine hits on the unit! If, for example, a hit had been rolled for the third marker instead, the player could have placed it anywhere in contact with or over markers 1 and 2, even directly on top of the first marker (as long as it causes the most hits on the target). If he did so, the salvo would have caused a total of ten hits instead of the nine caused in the example above.

## MELTA

Melta weapons are lethal, short-ranged 'heat rays'. They roll an extra D6 when rolling to penetrate a vehicle's Armour Value at half range or less. If the weapon is more than half its maximum range away, a single D6 is rolled as normal. See the Vehicles rules later for more details on armour penetration.

Example	Range	S	AP	Type
Meltagun	12"	8	1	Assault 1, Melta

## LANCE

These weapons fire a coherent, focused beam that can bore through any armour, regardless of its thickness. Due to their unique nature, lance weapons count vehicle Armour Values higher than 12 as 12.

Example	Range	S	AP	Type
Bright lance	36"	8	2	Heavy 1, Lance

# THE ASSAULT PHASE

While firepower alone may be enough to drive an enemy back from open ground or lightly held positions, shifting a determined foe from a fortified bunker or ruined settlement will need sterner measures. In an assault, troops storm forward, screaming their battle cries, eager to strike at their foes with knives, claws, bayonets or gun butts in a desperate close combat.

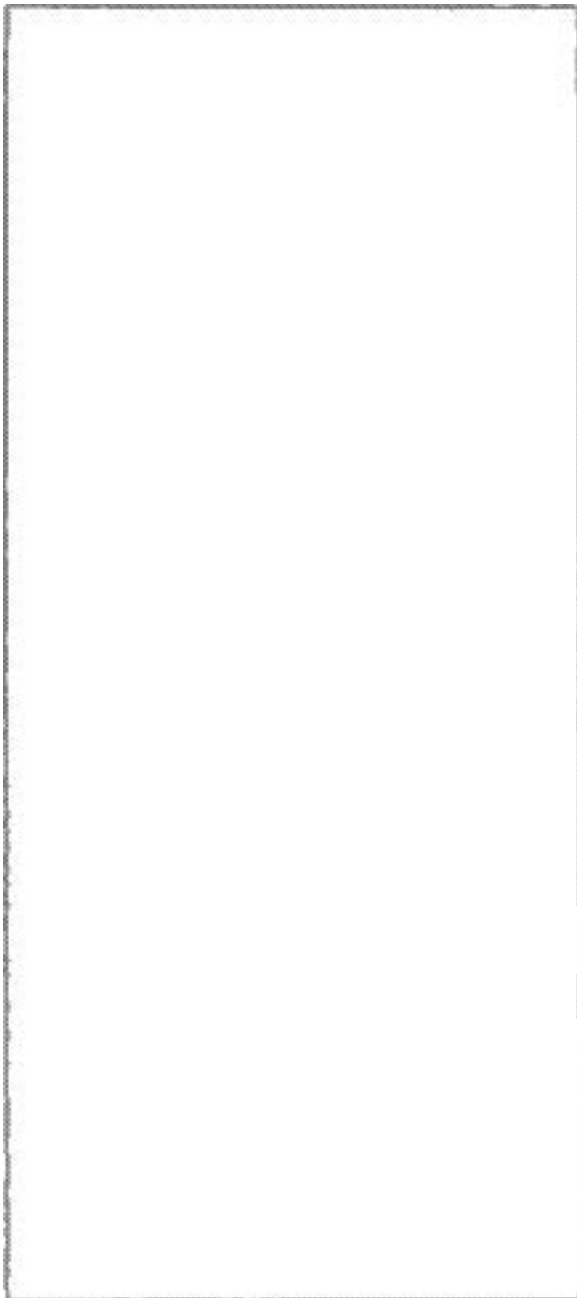

## DECLARE ASSAULTS

The maximum distance most units can move during an assault is 6". As you cannot measure the distance to the enemy before declaring the assault, if you misjudge the distance and the unit is unable to reach its target, then the unit does not move and that assault is ignored. Bear in mind that models may have to expend some of their movement to move around impassable terrain or other models in order to reach their enemy.

## DISALLOWED ASSAULTS

Units are not allowed to assault if:

- They are already locked in close combat.
- They ran in the Shooting phase (see page 16).
- They have gone to ground (see page 24).
- They shot rapid fire weapons or heavy weapons in the Shooting phase (see page 28).
- They are falling back (see page 45).

In addition to the above, a unit that fired in the Shooting phase can only assault the unit that it shot at – it cannot assault a different unit to the one it previously shot at. However, see the exception over the page for multiple targets.

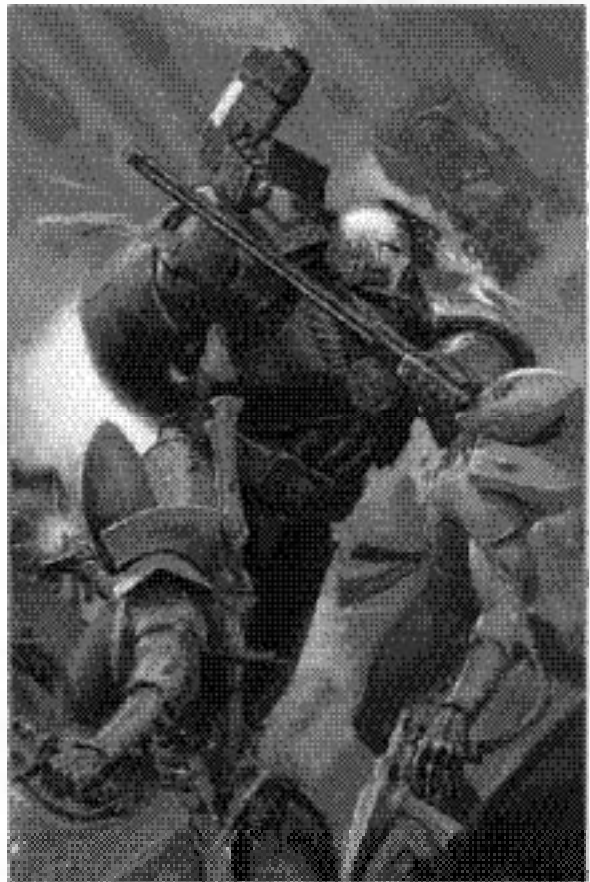

---

## MOVE ASSAULTING UNITS

---

Assaulting units must now move into close combat with the unit they have declared an assault against. A player must move all of the models in each assaulting unit before moving on to the next unit. The assaulting player decides the order in which his units will move.

### MOVING ASSAULTING MODELS

All of the models in an assaulting unit make their assault move following the same rules as in the Movement phase, with the exception that they may be moved within 1" of enemy models. This means that assaulting models may still not move through friendly or enemy models, may not pass through gaps narrower than their base, and may not move into base contact with enemy models from a unit they are not assaulting.

Assaulting units must attempt to engage as many opposing models as possible with as many of their models as possible – no holding back! Start each assault by moving a single model from the assaulting unit. The model selected must be the one closest to the enemy (going around impassable terrain, friendly models and enemy models in units not being assaulted). Move the model into contact with the nearest enemy model in the unit being assaulted, using the shortest possible route. Roll for difficult or dangerous terrain if necessary, and if the model is killed by a dangerous terrain test, start the assault again with the next closest model. If the closest model is found not to be within move distance to the enemy, that assault does not happen and no model is moved.

If the enemy is within range, then the assault move continues. After moving the first model in the unit, you can move the others in any sequence you desire. There are some constraints on their movement though:

- The most important one is that each model must end its assault move in coherency with another model in its own unit that has already moved.
- If possible, the model must move into base contact with any enemy model within reach that is not already in base contact with an assaulting model.
- If there are no such models in reach, the model must move into base contact with an enemy model that is already in base contact with an assaulting model.
- If a model cannot reach any enemy models, it must try to move within 2" of one of its own unit's models that is already in base contact with an enemy.
- If this is impossible, it must simply stay in coherency.

If you follow this sequence you will end up with all the models in the assaulting unit in unit coherency, having engaged as many enemy models as possible with as many assaulting models as possible.

## ASSAULTING MULTIPLE ENEMY UNITS

As you move assaulting models, you may find it is possible to reach other enemy units that are close to the one you are assaulting.

As usual the closest attacking model must be moved to contact the closest model in the enemy unit against which the assault was declared. Then remaining models can assault models belonging to other enemy units, as long as they keep following the rules for moving assaulting models. Remember that the assaulting unit is not allowed to break its unit coherency, and this will obviously limit the potential for this kind of assault.

If the assaulting unit shot in the Shooting phase then it must declare its assault against the unit it shot at, but it can engage other enemies as described here.

---

## DEFENDERS REACT

---

When their comrades come under attack, the remaining troopers rush forward to bolster the defence.

After all assault moves have been made, the player controlling the units that have been assaulted this turn must move any member of these units that is not yet in base contact with a foe towards the enemy.

These models move up to 6" in an attempt to move into base contact with an enemy. This follows the same rules as moving assaulting models, except that models are not slowed by difficult terrain and do not take dangerous terrain tests. Also, this move may not be used to contact enemy units that are not currently involved in the assault.

---

## FIGHTING A CLOSE COMBAT

---

How effective creatures are in close combat depends almost entirely on their physical characteristics – in other words how fast, strong, tough and ferocious they are. In close combat, armour remains as useful as ever for warding off blows and shots, but ranged weaponry becomes a secondary consideration – the best gun in the galaxy won't help if your opponent is bashing your brains out with a rock!

In close combat, both players' models fight. Attacks in close combat work like shots in shooting – each attack that hits has a chance to wound. The wounded model gets a chance to save, and if it fails is (generally) removed as a casualty. How many blows are struck and who strikes first is detailed later.

There may be several separate assaults being fought simultaneously in different parts of the battlefield. If this is the case, the player whose turn it is can choose the order in which to resolve the combats, completing each combat before moving on to the next one, and so on until all combats are resolved.

## WHO CAN FIGHT?

Close combat is a swirling melee of troops leaping, spinning, hacking and slashing at one another. As well as fighting hand-to-hand, warriors will be firing pistols at point blank range at any target that presents itself.

Units that have one or more model in base contact with enemies are said to be 'locked in combat'. Within such units, the following models are said to be 'engaged' and must fight:

- Models in base contact with any enemy models.
- Models within 2" of at least one model in their unit that is in base contact with any enemy models.

All engaged models will fight in this turn's Assault phase with their full number of Attacks and use any special close combat attack they have. Any models left unengaged because they are too far from an enemy model cannot attack this turn. However, they can still be killed by the enemy, and the result of the combat will still affect them.

Working out which models are engaged in combat is done at the start of the fight, and will not change until its end, but casualties may make it difficult to remember as the fight continues, especially in a large combat. To make the distinction clear, you may find it useful to turn unengaged models so that they are facing away from their opponents. This will help you to remember once the dice start rolling.

### Engaged models

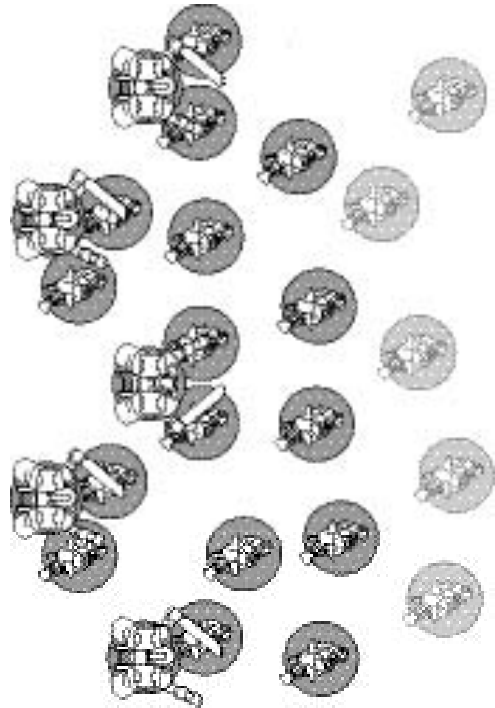

*All of the Gretchin in base contact with a Space Marine, and the ones within 2" of an Gretchin that is in base contact with a Space Marine are engaged and can therefore attack. The remaining Gretchin, shown in a lighter tone of grey, cannot attack.*



## WHO STRIKES FIRST?

It's all in the reflexes when it comes to close combat – slow, lumbering opponents can be dispatched quickly by a faster and more agile foe. Unfortunately, many cumbersome opponents, such as Orks, are tough enough to withstand a vicious pummeling and keep coming back for more.

In close combat, a model's Initiative characteristic determines who attacks first. Work your way through the Initiative values of the models engaged in the combat, starting with the highest and ending with the lowest. Models make their attacks when their Initiative value is reached, assuming they haven't already been killed by a model with a higher Initiative! If both sides have models with the same Initiative value, their attacks are made simultaneously. Note that certain situations, abilities and weapons can modify a model's Initiative.

*For example, a squad of Space Marines (Initiative 4) including a Veteran Sergeant with a power fist (which reduces his Initiative to 1) assaults a mob of Orks (Initiative 2). The Space Marines strike first at Initiative 4, followed by the Orks at 2, then the Sergeant strikes last at Initiative 1.*

---

**“Let's stomp some 'umies!”**

**Chazghkull Thraka**

---

## ASSAULTING THROUGH COVER

If, following the rules for moving assaulting models (see page 34), any model in an assaulting unit will have to go through difficult or dangerous terrain as part of its assault move, the unit must take the relevant terrain test before moving. This has two disadvantages. The first and most obvious is that such tests might cause the assault to fail altogether if the closest model cannot make it into contact with the enemy. Note that if a model stopped 1" away from the enemy in the Movement or Shooting phase, it can Assault even if its unit rolls a double 1 on its difficult terrain test.

The second disadvantage is that warriors who are assaulting through cover are subject to deadly salvos of close range fire as they slowly struggle to get to grips with their foe and may be ambushed by foes that are ready for them. To represent this, if an assaulting unit had to take a difficult or dangerous terrain test during their assault move, all of its models have their Initiative value lowered to 1 when attacking, regardless of other Initiative modifiers. Remember that assaulting models must try to engage as many enemies as possible – no holding back to avoid the test!

If all of the enemy units assaulted were already locked in combat from a previous turn or had gone to ground, this penalty does not apply as the enemy warriors are not set to receive the charge, and the unit assaulting through cover fights at its normal Initiative.

## GRENADES

Grenades in Warhammer 40,000 are generally used as part of an assault. A well-placed barrage of grenades can help immeasurably in the vital last few seconds it takes to overrun an enemy and come to grips. What follows are some of the most common types of grenades used in assaults. Any actual damage done by the grenade is assumed to be taken into account in the unit's attacks in close combat, but the unit using them gains the added benefit described below.

### Assault Grenades

**(e.g. frag grenades, plasma grenades, and so on)**

Assault grenades, like the ubiquitous fragmentation grenades or the more advanced Eldar plasma grenades, can be thrown at opponents in cover to force them to keep their heads down during an assault. The lethal storm of shrapnel (or the delayed plasma blast) from these grenades will drive opponents further under cover for a few precious moments, allowing attackers more time to close in. Models equipped with assault grenades don't suffer the penalty to their Initiative for assaulting enemies through cover, but fight as normal.

### Defensive Grenades

**(e.g., photon grenades, etc.)**

An example of defensive grenades are the photon grenades of the Tau, weapons that blind and disorientate the attacker with multi-spectral light and a sonic burst. Models assaulting against units equipped with defensive grenades gain no Assault Bonus attacks (see opposite). However, if the defending unit was already locked in combat from a previous turn, or had gone to ground, these grenades have no effect and the attackers gain the Assault Bonus attacks as normal.



## NUMBER OF ATTACKS

As explained earlier, models attack in order of Initiative. When their Initiative value is reached, models with that Initiative who are still alive must attack. It does not matter if all the enemies that they were engaged with have been killed – if a model was engaged at the start the fight (and is still alive when its turn to attack comes) it can still attack.

Each engaged model strikes with the number of Attacks (A) on its characteristics profile, plus the following bonus attacks:

- +1 Assault Bonus: Engaged models who assaulted this turn get +1 attack.
- +1 Two Weapons: Engaged models with two single-handed weapons (typically a close combat weapon and/or pistol in each hand) get an extra +1 attack. Models with more than two weapons gain no additional benefit – you only get one extra attack, even if you have more than two weapons.
- Other bonuses: Models may have other special rules and wargear that confer extra attacks.

Note that bonus attacks are an exception to the rules for characteristics' maximum modifiers and may bring a model's total attacks above 10!

*Example 1: A unit of five Space Marines with bolters normally roll five dice for their attacks in close combat. If they were assaulting they would roll ten dice (1 Attack +1 for assaulting = 2 each).*

*Example 2: A unit of five Orks with two close combat weapons normally roll fifteen dice (2 Attacks +1 for two weapons). If they were assaulting they'd roll twenty (2 Attacks +1 for assaulting +1 for two weapons = 4 each!).*

## ROLLING TO HIT

To determine whether hits are scored, roll a D6 for each attack a model gets to make. The dice roll needed to score a hit on your enemy depends on the relative Weapon Skills of the attacker and the target. Compare the WS of the attacking model with the WS of the target unit and consult the To Hit chart below to find the minimum score needed on a D6 to hit.

It is worth explaining the mechanic behind the chart, which is as follows: if the target's WS is lower than the attacker's, he hits on 3+; if the target's WS is equal or up to twice as high as the attacker's he hits on 4+, and if it is more than twice as high he hits on 5+.

Where the same roll to hit is needed, attacks should be rolled together, as this speeds up the game.

*In the previous example, the Ork player would therefore roll all of his twenty attacks together.*

### Units with different WS

A few units in Warhammer 40,000 contain models with different Weapon Skill values. Attacks against such units are resolved using the Weapon Skill of the majority of the engaged models. If there is no majority Weapon Skill, use the highest Weapon Skill of the models engaged.

*For example, a mob of 20 Gretchin (WS2) led by an Ork Runtherd (WS4) are all engaged in a combat. Since the Gretchin are in the majority, attacks against the unit are resolved using their WS of 2 – the Runtherd can't prevent the Gretchin getting hit. When the models attack, they calculate their own scores required to hit based on their individual Weapon Skill. So, when the Gretchin and Runtherd attack their enemies, the Gretchin will hit based on a comparison of their WS2 and the enemy's WS, while the Runtherd will compare his WS4 with the enemy's.*

## TO HIT CHART

		Target's Weapon Skill									
		1	2	3	4	5	6	7	8	9	10
Attacker's Weapon Skill	1	4+	4+	5+	5+	5+	5+	5+	5+	5+	5+
	2	3+	4+	4+	4+	5+	5+	5+	5+	5+	5+
	3	3+	3+	4+	4+	4+	4+	5+	5+	5+	5+
	4	3+	3+	3+	4+	4+	4+	4+	4+	5+	5+
	5	3+	3+	3+	3+	4+	4+	4+	4+	4+	4+
	6	3+	3+	3+	3+	3+	4+	4+	4+	4+	4+
	7	3+	3+	3+	3+	3+	3+	4+	4+	4+	4+
	8	3+	3+	3+	3+	3+	3+	3+	4+	4+	4+
	9	3+	3+	3+	3+	3+	3+	3+	3+	4+	4+
	10	3+	3+	3+	3+	3+	3+	3+	3+	3+	4+

NB. If a model has WS 0, all close combat attacks directed against it will hit automatically.

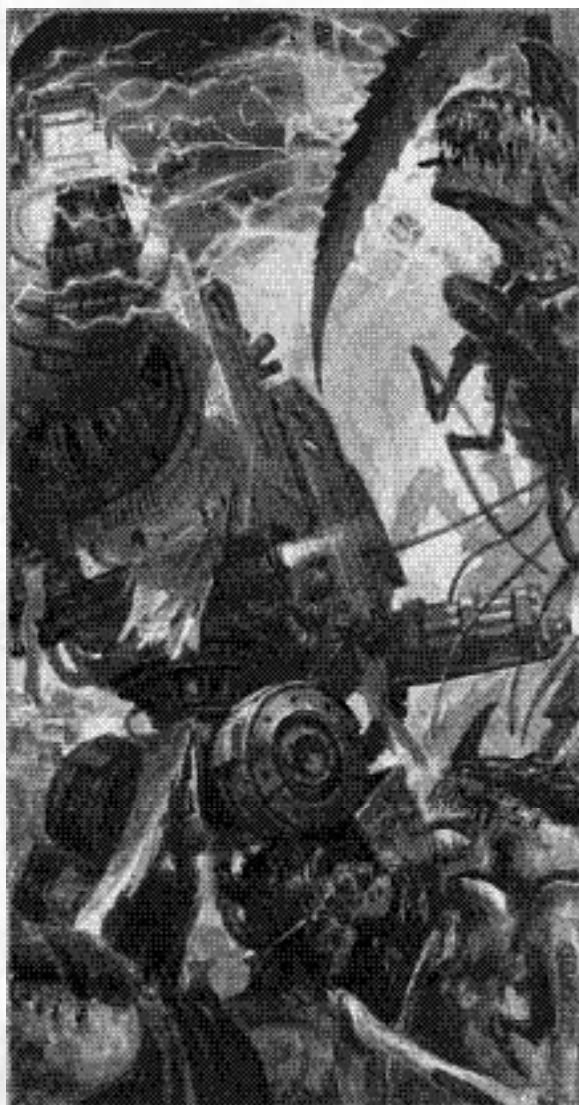

## ROLLING TO WOUND

Not all of the attacks that hit their mark will harm the enemy. They may be parried at the last moment or may merely inflict a graze or flesh wound. As with shooting, once you have scored a hit with an attack you must roll again to see if you score a wound and incapacitate your foe. Consult the chart below, cross-referencing the attacker's Strength characteristic (S) with the defender's Toughness (T). The chart, which is the same as the one in the Shooting section, indicates the minimum value on a D6 roll required to inflict a wound. In most cases, when rolling to wound in close combat, you use the Strength on the attacker's profile regardless of what weapon they are using. Some close combat weapons give the attacker a Strength bonus – this is explained later in Special Close Combat Attacks.

In a unit containing models with different Strength values, roll their attacks separately (they'll quite often have different Initiative characteristics too).

*For example, in a unit containing Gretchin and an Ork Runtherd, the Gretchin's attacks are made with their puny Strength of 2, but the Runtherd's attacks use his Strength of 3.*

### Multiple Toughness values

Quite rarely, a unit will contain models that have different Toughness characteristics. To keep things simple, roll to wound using the Toughness value of the majority of the engaged foe. If no majority exists, use the highest value in the unit.

---

**Know the mutant; kill the mutant.**

---

## TO WOUND CHART

		Toughness									
		1	2	3	4	5	6	7	8	9	10
Strength	1	4+	5+	6+	6+	N	N	N	N	N	N
	2	3+	4+	5+	6+	6+	N	N	N	N	N
	3	2+	3+	4+	5+	6+	6+	N	N	N	N
	4	2+	2+	3+	4+	5+	6+	6+	N	N	N
	5	2+	2+	2+	3+	4+	5+	6+	6+	N	N
	6	2+	2+	2+	2+	3+	4+	5+	6+	6+	N
	7	2+	2+	2+	2+	2+	3+	4+	5+	6+	6+
	8	2+	2+	2+	2+	2+	2+	3+	4+	5+	6+
	9	2+	2+	2+	2+	2+	2+	2+	3+	4+	5+
	10	2+	2+	2+	2+	2+	2+	2+	2+	3+	4+

*Note that N on the chart means the hit has no effect. A target with the Toughness indicated cannot be harmed by a hit of such puny Strength. Also note that a roll of 1 never scores a Wound, regardless of its Strength.*

### Allocating wounds

After determining the number of wounds inflicted against a unit at a particular Initiative value, the unit takes saves and casualties are removed as detailed below. Just like in the Shooting phase, if all the models in the unit are the same in gaming terms, you can carry straight on and roll all the saves in one batch. Otherwise, wounds are allocated against the target unit by the controlling player, exactly like the fire of a single enemy unit during the Shooting phase (refer back to page 25).

Either way, all of the models in the target unit can be hit, wounded and killed, including those that are not engaged. This represents the fact that each fighter is contributing his shots and blows to the swirling combat while warriors are rushing forward to replace their comrades that fall under the blows of the enemy. Indeed it is a good tactic to allocate wounds on models that are not engaged, as it will often allow your engaged models to survive long enough to attack back! Remember to use different coloured dice or otherwise mark out the wounds that have different special rules attached to them (like those inflicting instant death or those that ignore armour saves), as you would do in the Shooting phase.

### TAKING SAVES

Models struck and wounded in close combat can attempt armour saves to avoid becoming casualties. Models usually get to save regardless of the attacker's Strength, but some especially monstrous creatures and powerful close combat weapons will punch straight through armour. Otherwise, the procedure for taking saves is the same as the one described for Shooting.

Cover does not provide protection in close combat as it does against shooting. This means that models do not get cover saves against any wounds suffered in close combat, and for obvious reasons cannot go to ground.

Remember that even if the rules for a weapon or attack states that no armour save is allowed, an invulnerable save may still be made.

### REMOVING CASUALTIES

All of the rules for removing shooting casualties apply in close combat.

If a model becomes a casualty before it has an opportunity to attack, then it may not strike back. When striking blows simultaneously, you may find it more convenient to resolve one side's attacks and simply lay wounded models on their side to remind you that they have yet to attack back.

---

**The Martyr's grave is the  
foundation of the Imperium.**

---

### Removing casualties in close combat



*The Ork player  
removes casualties  
from unengaged  
models, so that his  
engaged Gretchin  
live to strike back.*

## DETERMINE ASSAULT RESULTS

Assaults are usually decisive, one side or the other quickly gaining the upper hand and forcing back their foe. Good Leadership can keep a side in the fight, but the casualties that each side inflicts are usually the most telling factor. To decide who has won the combat, total up the number of unsaved wounds inflicted by each side on their opponents. The side that caused the most is the winner. The losing side must take a Morale check and will fall back if they fail.

If both sides suffer the same number of wounds, the combat is drawn and continues next turn.

Of course, if one side destroys the enemy it wins automatically, even if it sustained more casualties!

Note that wounds that have been negated by saving throws or other special rules that have similar effects do not count, nor do wounds in excess of a model's Wounds characteristic, only the wounds actually suffered by enemy models (including all of the Wounds lost by models that have suffered instant death). In rare cases certain models can cause wounds on themselves or their friends – obviously these wounds are added to the other side's total for working out who has won.

## CHECK MORALE

Units that lose a close combat must take a Morale check to hold their ground, with a penalty depending on how severe the defeat was (see page 44). If they pass, the unit fights on – the combat is effectively drawn and no further account is made of the unit's defeat (apart from some good-natured taunting by the winner!). If they fail, they must abandon the fight and will fall back. Morale checks and falling back are covered in the Morale section on page 43.

---

## **SWEEPING ADVANCES**

When a unit falls back from combat, the victors make a Sweeping Advance, attempting to cut down the retreating enemies.

Both the unit falling back and the winning unit roll a D6 and add their Initiative value to the result. Always count the Initiative value from the model's profile without any modifiers. In a unit with mixed Initiative characteristics, count the majority value, or the highest if there is no majority.

They then compare their totals.

- If the winner's total is equal or greater they catch the fleeing enemy with a sweeping advance. The falling back unit is destroyed. We assume that the already demoralised foe is comprehensively scattered, ripped apart or sent packing, its members left either dead, wounded and captured, or at best fleeing and hiding. The destroyed unit is removed immediately. Unless otherwise specified, no save or other special rule can rescue the unit at this stage; for them the battle is over.
- If the falling back unit's total is higher, they break off from the combat successfully. Make a fall back move for the losing unit (see page 45). The winners can then consolidate as detailed below.

### **DISALLOWED SWEEPING ADVANCES**

If a victorious unit is still locked in combat with other units that are not falling back, it does not get a chance to execute a sweeping advance and the retreating enemy falls back safely.

Some troops, as detailed in their entries, are not allowed to make a sweeping advance – in such cases the enemy always manage to disengage safely.

---

### **PILE-IN!**

After the combat been resolved, it might happen that some models from units that did not fall back from the combat are not in base contact with an enemy. These models must make a pile-in move.

Just like when defenders react to being assaulted, these models move up to 6" in an attempt to move into base contact with an enemy or, if not possible, into a position in which they are engaged and will be able to fight. This follows the same rules as moving assaulting models, except that is not slowed by difficult terrain and does not trigger dangerous terrain tests. Also, a pile-in move may not be used to contact enemy units that are not currently involved in the assault.

When making pile-in moves, the player whose turn it currently is moves first. If for some reason (mass carnage, usually), his model's pile-in moves are

insufficient to move into base contact with any enemy that was involved in that fight, the player must still move them as close as possible to such enemies. The opponent will then execute his own models' pile-in moves, back into contact with the enemies they were fighting. If both units' pile-in moves combined (that's more than 12" – very unlikely!) would be insufficient to bring the combatants back together, the assault comes to an end and both sides may make consolidation moves instead, as described below.

While a unit is locked in combat it may only make pile-in moves and may not otherwise move or shoot.

---

### **CONSOLIDATION**

At the end of a combat, if a unit's opponents are all either destroyed or falling back, so that the victorious unit is no longer locked in combat with any enemy, they may consolidate. This means that they may move up to D6" in any direction, as the sudden victory may leave the warriors raring to storm onward or flat-footed and dumbfounded, according to the vagaries of fate.

Units making a consolidate move are not slowed by difficult terrain and do not trigger dangerous terrain tests. A consolidation move may not be used to move into base contact with enemy models, as this can only be done with an assault move. Consolidating models must therefore stop 1" away from all enemy models, including any that might have just fallen back from the combat that the consolidating unit has fought in.

---

### **SHOOTING INTO & OUT OF CLOSE COMBAT**

Models belonging to units locked in combat may not fire weapons in the Shooting phase. Their attention is completely taken by the swirling melee. Likewise, while especially twisted and soulless commanders may wish their warriors to fire indiscriminately into the middle of close combats in the hopes of hitting the enemy, this is not permitted. The events in a close combat move too quickly and the warriors themselves will be understandably hesitant about firing on their comrades.

While blast markers and templates may not be deliberately placed such that they cover any models locked in combat, they may end up there after scattering and will then hit any models they touch (friends and foes!).

Units that are locked in close combat do not have to take Morale and Pinning tests caused by shooting; they are considered to be much too focused on fighting to be worried about being shot at!

---

**There is no substitute for zeal.**

---

## MULTIPLE COMBATS

Combats that involve more than two units are called 'multiple combats' (see the diagram below for an example). Because of the extra complexity, they need some additional rules, which are provided on this page.

### DEFENDERS REACT

If a unit that is already locked in combat from a previous turn is assaulted by a new enemy unit, it can react as normal. Its models must be moved into base contact with models from any of the units that they are fighting, not just the enemies that just assaulted them.

### ATTACKING

In multiple combats, when it is time for a model to attack, the following extra rules apply:

- Models that were engaged with just one of the enemy units at the beginning of the combat (before any model attacked) must attack that unit.
- Models that were engaged with more than one enemy unit at the beginning of the combat (before any model attacked) may split their attacks freely between those units. Declare how they are splitting their attacks immediately before rolling to hit.

### ASSAULT RESULTS

When determining assault results in a multiple combat, total up the number of wounds inflicted by each side to see which side is the winner. Every unit on the losing side has to check their Morale (they all use the same penalty, as described in the Morale section). After all of the losing units have taken their Morale checks, any winning unit that is now free to make a sweeping advance rolls the dice and compares its total with the total of each of the falling back enemy units it was engaged with. Any that it equals or beats are destroyed. Remember that winning units can only sweep advance if all of the units they were locked with fall back or are wiped out in the fight.



After assault resolution, all units that were involved in that multiple combat must make pile-in moves towards enemies that fought in that combat. If a unit's pile-in cannot reach any such enemies, the unit must move as close as possible to the enemy to allow them to pile-in into contact. If it is impossible, both sides consolidate.

#### Multiple combat

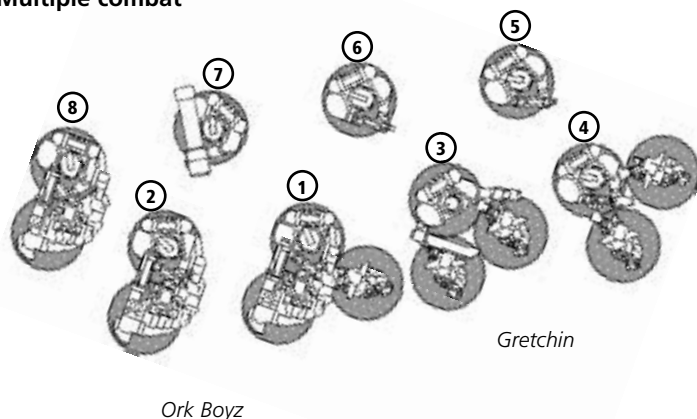

*The Space Marines have charged the Orks and Gretchin. Space Marine 1 can choose to attack either the Orks or the Gretchin (or split his attacks). Space Marines 6 and 7 can also choose to fight either enemy unit (or split their attacks), because they are within 2" of a member of their own unit who is in base contact with both enemy units.*

*Space Marines 2, 3, 4 and 8 can only attack the units they're in base contact with. Space Marine 5 can only attack the Gretchin (as he is only within 2" of members of his own unit that are in base contact with the Gretchin).*

## CLOSE COMBAT WEAPONS

On the battlefields of the 41st Millennium, close combat remains commonplace – seasoned warriors often bear a deadly array of combat knives and frag grenades, while specialised assault troops take pistols, swords and deadly power weapons into battle. In terms of rules, they are all grouped into either of the following two categories:

### NORMAL CLOSE COMBAT WEAPONS

Weapons like chainswords, rifle butts, combat blades, bayonets, etc., do not confer any particular bonus to the model using them. Remember that, in close combat, pistols count as normal close combat weapons and so the Strength and AP of the pistol are ignored.

### SPECIAL CLOSE COMBAT WEAPONS

These include more complex and powerful weapons that enhance the wielder's combat skills and confer bonuses, and sometimes penalties, to the models using them. The most widely used are listed below:

#### Power weapons

A power weapon is sheathed in the lethal haze of a disruptive energy field, which eats through armour, flesh and bone with ease. Models wounded in close combat by the attacks of a model armed with a power weapon are not allowed armour saves.

#### Lightning claws

Lightning claws are commonly used as matched pairs and consist of a number of blades, each a mini-power weapon, normally mounted on the back of the hand. A lightning claw is a power weapon and it also allows the wielder to re-roll any failed roll to wound.

#### Force weapons

These psychic weapons are described on page 50.

#### Poisoned weapons

Poisoned weapons range from blades coated in venom to hypodermic claws. They do not rely on a comparison of Strength and Toughness to wound – they always wound on a fixed number, generally shown in brackets. In most cases this is 4+. Some venoms are so lethal that the merest drop can kill – these may wound on a 3+, or even 2+ (as described in the appropriate Codex). In addition, if the Strength of the wielder is the same or higher than the Toughness of the victim, the wielder must re-roll failed rolls to wound in close combat. These weapons confer no advantage against vehicles.

#### Power fists

A power fist (or 'power claw') is an armoured gauntlet surrounded by a disruptive energy field. A power fist is a power weapon, and also doubles the user's Strength (up to a maximum of 10). Power fists, however, are difficult and cumbersome to use, so attacks with a power fist are always delivered at Initiative 1 (ignore Initiative bonuses from special rules, wargear, etc.).

#### Thunder hammers

Thunder hammers release a tremendous blast of energy when they strike. A thunder hammer uses the same rules as a power fist. In addition, all models that suffer an unsaved wound from a thunder hammer and are not killed will be knocked reeling, reducing their Initiative to a value of 1 until the end of the next player's turn. Against vehicles with no Initiative value, whenever a thunder hammer inflicts any damage result, it also inflicts a crew shaken result (see page 61).

#### Rending weapons

If a model armed with a rending close combat weapon rolls a 6 on any of his rolls to wound in close combat, the opponent automatically suffers a wound, regardless of its Toughness. These wounds count as wounds from a power weapon. Against vehicles, an armour penetration roll of 6 allows a further D3 to be rolled, with the result added to the total score.

#### Witchblades

These psychically attuned weapons are often carried by Eldar psykers. All hits scored in close combat by models armed with a witchblade inflict wounds on a roll of 2+, regardless of the target's Toughness. Armour saves are taken as normal. Against vehicles, the wielder of a witchblade counts his Strength as 9.

## FIGHTING WITH TWO SINGLE-HANDED WEAPONS

Some models are equipped with two single-handed weapons they can use in close combat, with the rules given below for the different possible combinations. Of course, if a model is using a two-handed close combat weapon (such as a rifle's butt or a two-handed battle axe), it may not use it together with another weapon.

#### Two normal close combat weapons

These models gain one bonus attack (see page 37).

#### Two of the same special weapon

These models gain one additional attack. All of their attacks, including the bonus attack, use the special weapon's bonuses and penalties.

#### A normal and a special weapon

These models gain one additional attack. All of their attacks, including the bonus attack, benefit from the special weapon's bonuses.

Power fists, thunder hammers and lightning claws are an exception to this. Only a second power fist, thunder hammer or lightning claw can confer a bonus attack to a model equipped with one of these weapons.

#### Two different special weapons

When it is their turn to attack, these models must choose which weapon to use that turn, but they never get the bonus attack for using two weapons (such is the penalty for wielding too many complex weapons!).

# MORALE

**It is a fortunate commander who can always rely on his troops to perform fearlessly. In the chaos and confusion of battle, troops can easily become demoralised, disoriented or simply terrified by the violence unleashed against them. To represent this element of the unknown, your units of troops have to check to see if their morale holds under certain circumstances. As you will have already gathered, particular events will require that your troops take a Morale check, and a unit in particularly dire straits may be forced to take several Morale checks in a single turn.**

Morale checks are a specific kind of Leadership test. Note that Leadership tests are used for other functions in Warhammer 40,000, such as using Psychic powers.

---

## MORALE CHECKS

---

Morale represents the grit, determination, or (sometimes) plain stupidity of warriors in action. Like all other Leadership-based tests, Morale checks (also called Morale tests) are taken by rolling 2D6 and comparing the total to the unit's Leadership value. If the score is equal to or under the unit's Leadership value, the test is passed and the unit does not suffer any ill effects – their nerve has held. However, if the score rolled is higher, then the test is failed and the unit will immediately fall back, as described over the page.

Some units have special rules pertaining to Morale checks that are detailed in the appropriate Codex. For example, some particularly fanatical units may be immune to the effects of morale. Some units always pass Morale checks, while a few others always pass all Leadership tests. This is a subtle but important difference. For example, units that always pass Morale checks will still have to test for Pinning.

---

**“Warriors of Ultramar! This is where we make our stand. If death is to be our fate then we shall meet it with the Emperor’s word on our lips and his light in our eyes. If we must die, we will die; but we shall never yield.”**

Marnus Calgar, Lord Macragge

---

## MORALE CHECK MODIFIERS

Certain circumstances can make Morale checks harder for a unit to pass. This is represented by applying Leadership modifiers to Morale checks, which can reduce the unit's Leadership value by -1, -2 or sometimes even more.

## INSANE HEROISM!

Occasionally, warriors will refuse to retreat even when faced with impossible odds or particularly harrowing experiences. Sometimes you can push someone just too far! A score of double 1 on the 2D6 roll always indicates the unit has passed its Morale check, regardless of modifiers.

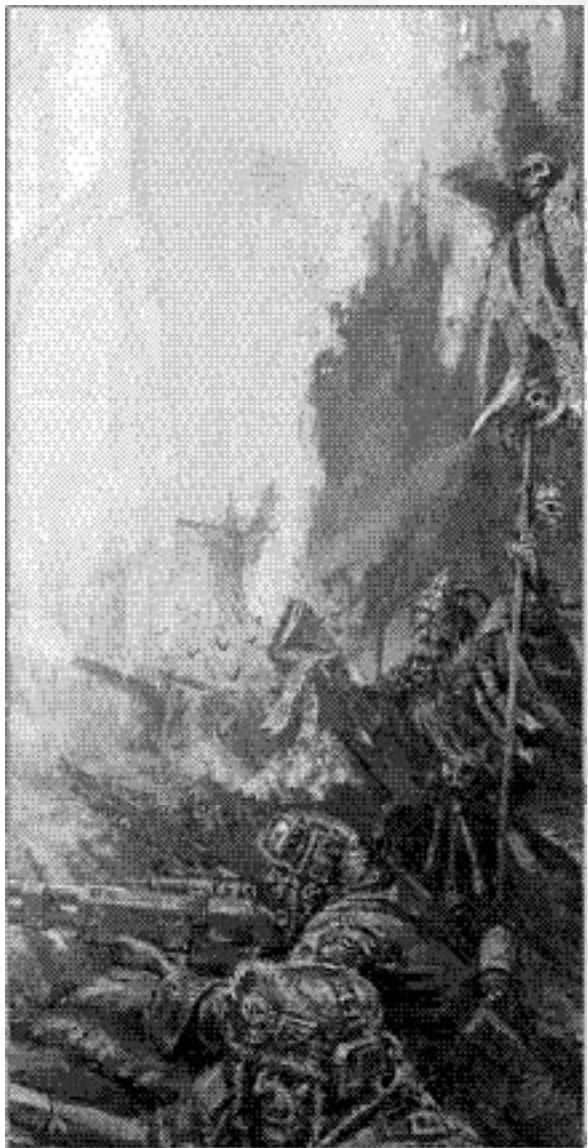

## TAKING MORALE CHECKS

Units normally have to take a Morale check in the following situations:

### A) Casualties

A unit losing 25% or more of its models during a single phase must pass a Morale check at the end of that phase, or else it will fall back. Do not count casualties caused by close combat attacks, as they are covered later in C) Losing an Assault.

A unit that is locked in close combat does not have to take Morale checks for taking 25% casualties.

*Example: A unit of five troops suffers two casualties from enemy shooting, so it takes a Morale check, which it promptly passes. Next turn, the unit, now three strong, suffers a single casualty from shooting, which is now enough for it to have to take another Morale check.*

### B) Tank Shock

Units that are overrun by an enemy tank may wisely decide it's time to abandon their position and fall back. If a tank reaches an enemy unit's position then the unit must take a Morale check to see whether or not it falls back. For a more complete explanation of how tank shock works, see the Vehicle rules on page 68.



### C) Losing an Assault

Units that lose a close combat (ie, they suffer more wounds than they inflict) must pass a Morale check to hold their ground. If they fail, they must fall back.

Units taking this Morale Check suffer a -1 Ld modifier for each wound their side has lost the combat by.

*Example: An Imperial Guard squad has lost an assault. They would normally require a 7 or less to pass the Leadership test, but since they have lost the fight by a difference of 2 Wounds (-2), they now require a 5 or less to hold their ground.*



## NO RETREAT!

It's not uncommon for units to be immune to Morale checks for losing an assault, or to automatically pass them for some reason (they may have the 'fearless' special rule, be subject to a vow or some other special rule). When such units lose a close combat, they are in danger of being dragged down by the victorious enemy despite their determination to hang on.

These units do not take Morale checks and will never fall back. Instead, these units suffer a number of wounds equal to the number their side has lost the combat by (allocated as normal).

All types of saving throws, except for cover saves, can be taken against these wounds.

*For example, after all blows are struck, a fearless unit has lost the fight by a difference of 3. The fearless unit does not take a Morale test, but it immediately suffers three wounds and will take three armour saves.*

If none of the enemies involved in the combat against a fearless unit can actually hurt it, the unit does not suffer any wounds if its side is defeated in combat, and simply continues to fight.

---

**“A good soldier obeys without question.  
A good officer commands without  
doubt.”**

Tactica Imperium

---

## FALL BACK!

A fall back move is a fighting withdrawal rather than an out-and-out rout. Sometimes a fighting retreat in the face of overwhelming odds is the only option left. A withdrawal can give troops the chance to retire to a stronger position, to regroup and mount a fresh attack, or to hold back the approaching enemy.

Units make a fall back move immediately upon failing a Morale test. In each subsequent Movement phase, they will make further fall back moves instead of moving normally, until the unit regroups, is destroyed or leaves the table.

Units normally fall back 2D6". Fall back moves are not slowed by difficult terrain, but tests for dangerous terrain are taken as normal.

Each model in the unit falls back directly towards their own table edge by the shortest possible route. If playing a mission where there is no 'own' table edge, models fall back towards the closest table edge instead.

If any model from a unit that is falling back moves into contact with a table edge, the entire unit is removed from the game and counts as destroyed, as it scatters and deserts the battle.

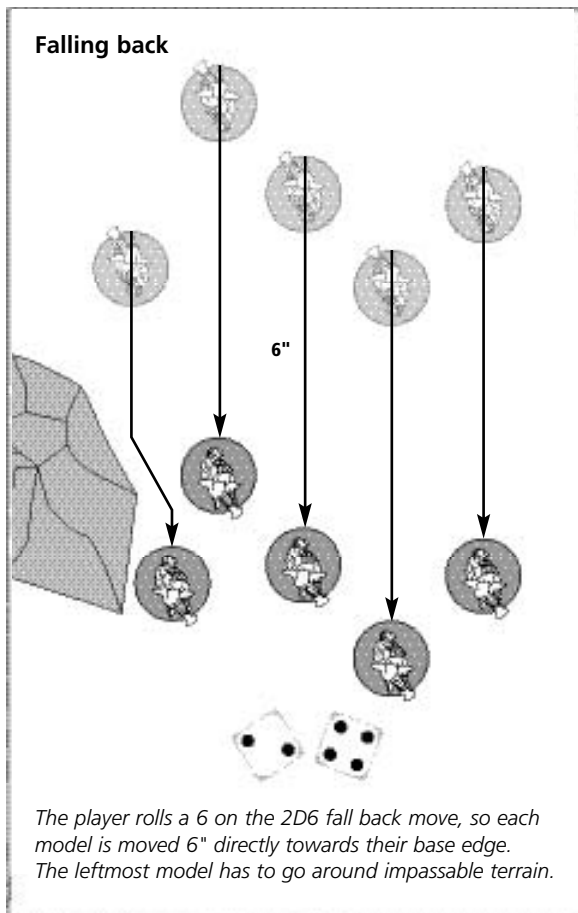

## FALLING BACK FROM CLOSE COMBAT

Models falling back from a combat will move through all enemy models that were involved in that combat (these enemies have already missed their chance of catching the falling back unit!). If any models would end their move less than 1" from one of these enemies, extend the fall back move until they are clear.

## TRAPPED!

Sometimes a unit will find its fall back move blocked by impassable terrain, friendly models or enemy models (remember they have to stay 1" away from enemy models). The models in the falling back unit may move around these obstructions in such a way as to get back to their table edge by the shortest route, maintaining unit coherency.

If the unit cannot perform a full fall back move in any direction without doubling back, it is destroyed (see diagram below).

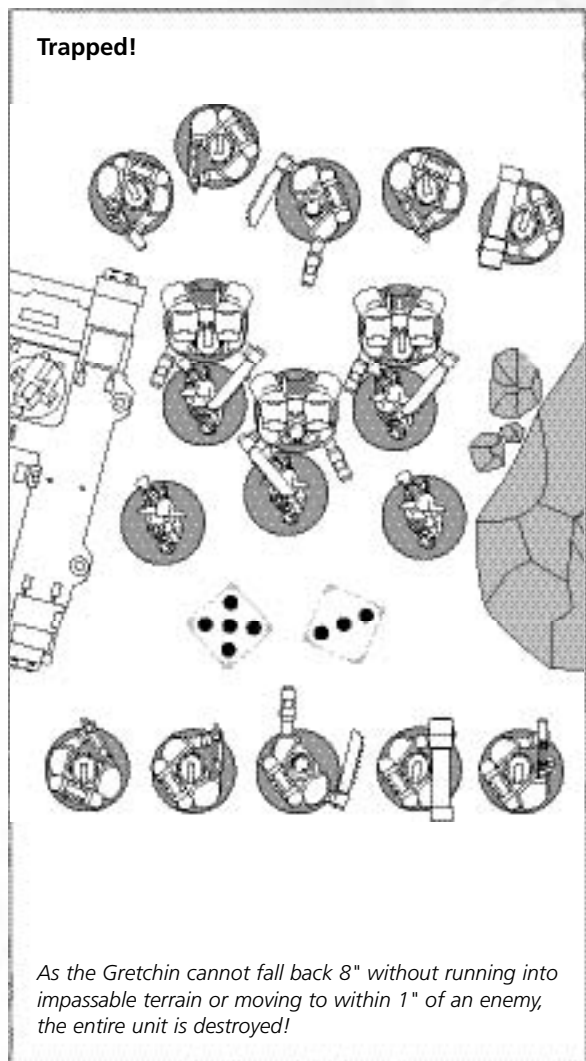

## FIRING WHILE FALLING BACK

Units that are falling back may not go to ground and automatically pass Pinning tests.

Troops who are falling back may continue to shoot, but obviously count as moving. They may of course choose to run instead of firing, but if they do so it must be towards their own table edge.

## ASSAULTS WHILE FALLING BACK

A unit that is falling back may not launch assaults.

If an enemy unit declares an assault against a unit that is falling back and is found to be in range, the falling back unit must immediately test to regroup (see right). If the test is successful, the unit regroups (without moving), and from then on the fight continues as normal, starting with the enemy moving in his assaulting models. If the test is failed, the unit is destroyed and the assaulting unit does not move at all.

Sometimes a unit that is assaulting an enemy unit that is not falling back can, as part of a multiple assault move, also contact models from a nearby enemy unit that is falling back. As soon as one assaulting model is found to be able to move into contact with the falling back unit, test to regroup as described above. If the test is successful, the unit regroups (without moving) and the assault continues as normal. If the test is failed, the falling back unit is destroyed and the assaulting model must continue its assault move as if the falling back unit was never there.

## MORALE WHILE FALLING BACK

Troops who are falling back automatically fail all Morale checks, except those to regroup (see right).

## REGROUPING

Just because a unit falls back doesn't mean it is out of the fight. Courageous officers will try to inspire their troops to rally. Warriors might regain their will to fight out of honour, duty or sheer bloody-mindedness.

A unit falling back can attempt to regroup by taking a Regroup test in the Movement phase just before they move. This is a special type of Leadership test, which falling back units cannot attempt if any of the following conditions apply:

- The unit is below half strength.
- There are enemies within 6".
- The unit is not in coherency.

Units that are assaulted while falling back must always attempt this test as soon as the enemy is found to be in assault range, and can do this regardless of any of the above restrictions (the alternative is just too bad!).

If the unit successfully passes its Leadership test, it stops falling back and regroups. The unit can immediately move up to 3" (this move is unaffected by difficult terrain, but dangerous terrain tests must be taken as normal).

Once a unit has regrouped, it cannot otherwise move during that Movement phase, but otherwise it behaves as normal. For example, it can shoot (though it always counts as moving on the turn it regroups) or run, and it can even launch an assault if it gets the chance.

If the unit fails its Leadership test, (or cannot regroup because of the restrictions given above), then it must immediately continue to fall back.

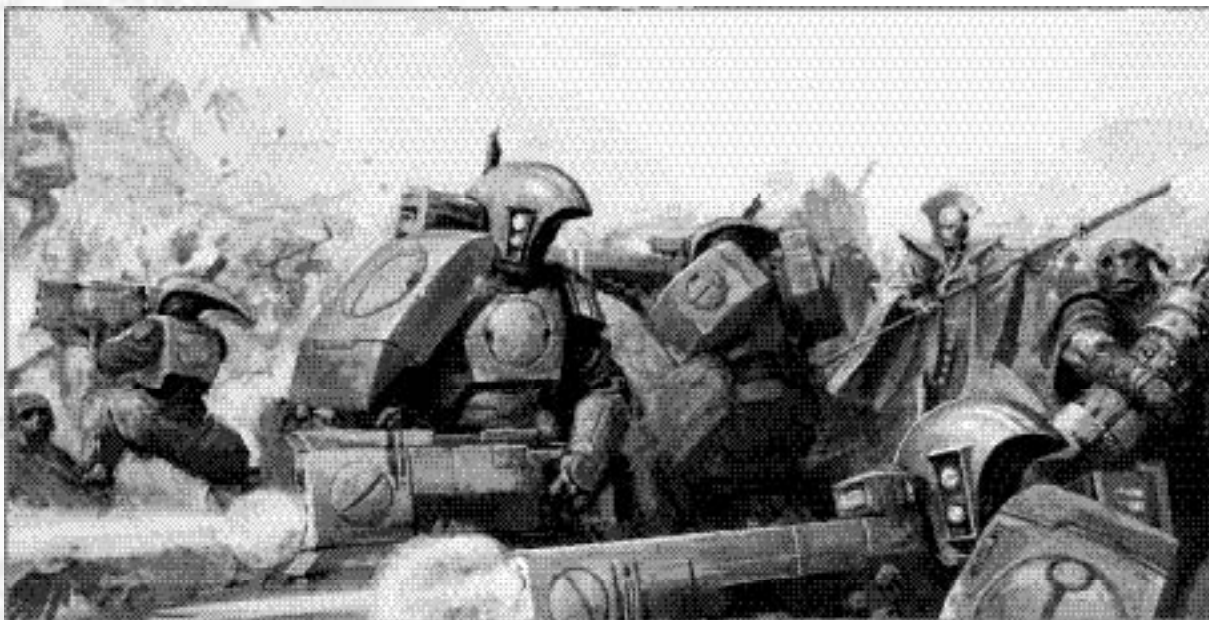

# CHARACTERS

**Veteran warriors, brilliant officers, possessed prophets and ferocious war-leaders can inspire the troops to great feats of heroism (or fiendish bravery as the case may be) and are often quicker, stronger and more skilled in combat. In Warhammer 40,000 these kinds of powerful individuals are called 'characters'.**

## CHARACTER TYPES

Warhammer 40,000 armies normally include two types of characters:

- Independent characters are represented by individual models, which fight as units in their own right. One of the most useful abilities of independent characters is to join other units in battle, so that they can move in to bolster the battle line where the fighting is fiercest. If a model is an independent character, it will have its own entry in the appropriate Codex, and its rules will also clearly state that the model is an independent character. Bear in mind that there are other models that only ever fight as units of one model, but are not independent characters.
- Upgrade characters are fielded as part of units from the start of the game, representing a squad leader or unit champion, such as a Space Marine Veteran Sergeant. They do not have an entry of their own and are effectively just another trooper in their unit, with enhanced characteristics and perhaps a wider selection of weapons and wargear choices.

### **'What You See Is What You Get'**

*Character models in particular tend to have a lot of options as to what weapons and wargear they can use – given in the army list of their Codex. The rule is that such equipment must be visually represented on the model so your opponents can clearly see what they are facing. This concept is often referred to as WYSIWYG, which stands for 'what you see is what you get'.*

*Of course, many gamers enjoy trying out different combinations of wargear in different battles. So, for example, a player might decide that for his next game a model's power sword will simply count as a close combat weapon, but he will also equip the model with melta bombs. While some tournaments may be more strict about this kind of thing, most opponents are happy to accommodate a small degree of one thing counting as another, so long as you explain exactly who has what at the start of the game.*

## CHARACTERS AS LEADERS

Remember that a unit's Leadership tests are taken using the Leadership of the model with the highest Ld value in the unit (see page 8). As characters normally have a better Ld than other warriors, this means that they make very good leaders for other units in the army.

## INDEPENDENT CHARACTERS

### MOVING INDEPENDENT CHARACTERS

Independent characters follow the Movement rules for models of their type, be it infantry, jump infantry, bike, etc. In addition, independent characters can move through difficult terrain more quickly and safely than ordinary troops. All independent characters have the 'move through cover' and 'skilled rider' special rules (see pages 75 and 76). This advantage does not extend to any vehicles they may be travelling in.



## INDEPENDENT CHARACTERS JOINING & LEAVING UNITS

Independent characters are allowed to join other units. They cannot, however, join vehicle squadrons (see the Vehicles section) and units that always consist of a single model (like most vehicles and monstrous creatures). They can join other independent characters though, to form a powerful multi-character unit!

- In order to join a unit, an independent character simply has to move so that he is within the 2" coherency distance of a friendly unit at the end of their Movement phase. If the character is within 2" of more than one unit at the end of its Movement phase, the player must declare which unit it is joining. If a character does not intend to (or cannot) join a unit, it must remain more than 2" away from it at the end of the Movement phase. This is to make clear to the opponent if the character has joined a unit or not. Note that after a character joins a unit, that unit may move no further that Movement phase.



- Alternatively an independent character may begin the game already with a unit, by being deployed in coherency with them.
- While an independent character is part of a unit, he must obey the usual coherency rules. The combined unit moves and assaults at the speed of the slowest model while they stay together.
- An independent character can leave a unit during the Movement phase by moving out of coherency distance with it.
- If an independent character moves and joins or leaves a unit that did not move, the character counts as having moved in the ensuing Shooting phase, but the unit does not.
- An independent character may not join or leave a unit during the Shooting and Assault phases – once shots are fired or assaults are launched it is too late to join in or duck out!
- An independent character may not join or leave a unit while either he or the unit is locked in combat or falling back.
- If an independent character joins a unit that has gone to ground, he immediately goes to ground as well, and vice versa. He may not leave as long as his unit has gone to ground.

### Special Rules

When an independent character joins a unit, it might have different special rules from those of the unit. Unless specified in the rule itself (as in the 'stubborn' special rule), the unit's special rules are not conferred upon the character, and the character's special rules are not conferred upon the unit. In some cases though, the independent character or the unit may lose their special rules as a result of the character joining the unit. For example, if an independent character without the 'infiltrate' special rule joins a unit of infiltrators during deployment, the unit cannot infiltrate (see the Universal Special Rules section for more details).

### Retinues

Some Codex books allow you to field characters together with a special unit that they cannot leave during the game (which is normally called a 'retinue', 'bodyguard' or similar). Where this is the case, the character counts as an upgrade character until all of the other members of this unit are killed, at which point it starts counting as an independent character and it will do so for the rest of the game.

## INDEPENDENT CHARACTERS & SHOOTING

### Shooting at independent characters

In the heat of battle it is often hard to distinguish individuals, and even harder to pick them out as specific targets. Independent characters that have joined a unit are considered part of that unit and so may not be picked out as targets. If the unit they have joined is hit, the controlling player can choose to allocate hits against the characters just like the other members of the unit. This gives you some tricky tactical choices as a character may be able to soak up more damage than the normal troopers, but will be a serious loss if he is killed.

Independent characters that have not joined a unit can be targeted as normal, being separate units.

Independent characters that are monstrous creatures can always be picked out as separate targets, unless they've joined a unit of monstrous creatures or a unit with special rules that offer them protection.

### Independent characters shooting

All independent characters shoot just like ordinary troopers, although in many cases they will have better Ballistic Skill or exotic weaponry that sets them apart. If they have joined a unit, either roll for them separately or use different coloured dice to differentiate their shooting. However, they must still fire at the same target as the unit they have joined.

## INDEPENDENT CHARACTERS & ASSAULTS

In the Assault phase, an independent character on his own can assault into close combat if within range of the enemy as normal.

If a unit that has been joined by an independent character assaults into close combat, the character assaults too, as it is part of the unit. When the attacks are resolved, however, independent characters are always treated as a separate single-model unit (as described under Multiple Combats on page 41), even though they have joined the unit. This is to make them stand out in the fight, as befits such heroic individuals, and it means that they have to be in base contact with the enemy to be able to attack. Be aware, though, that this also means that independent characters can be targeted separately by models that are engaged with them! Once all attacks have been resolved, these characters are once again treated as normal members of the unit they have joined (from determining assault results onwards).

When a unit is reacting to being assaulted, or making a pile-in move, independent characters that have joined the unit must move before other friendly models in order to get into base contact with an enemy if at all possible (otherwise they will not be able to fight). Using their own men as a screen in order to avoid the fight is a cowardly act, one that these great heroes would never consider!

### Independent characters in combat

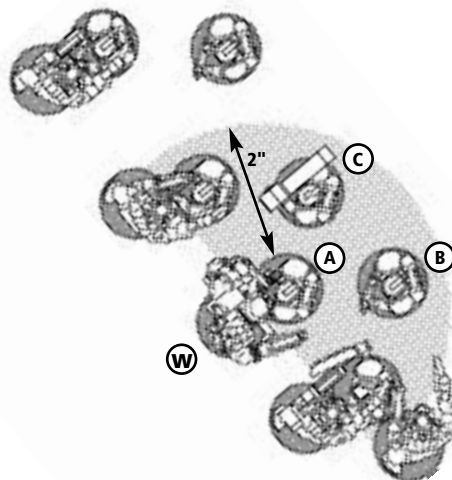

*The Ork Warboss (W) is an independent character and so counts as a separate unit. Space Marine (A) can only attack the Warboss. Space Marines (B) and (C) can attack either the Warboss or the Ork unit. All of the other Space Marines can only attack the Ork unit, as they are not engaged with the Warboss.*

## SPECIAL CHARACTERS

The 41st Millennium is filled with famous characters renowned as legendary heroes or infamous villains – these unique individuals, who stand out from normal characters because they have a personal name and not just a title, are called 'special characters'. Special characters are highly skilled and dangerous heroes who have incredible traits or skills that make them particularly valuable to an army.

For example, Commissar Yarrick is without doubt the most respected Imperial Guard Commissar in the Imperium, his inspiring presence securing the world of Armageddon against two massive Ork invasions within the space of fifty years. An army led by him can expect great benefits in terms of morale and leadership. On the other hand, Khârn the Betrayer, an Exalted Champion of the Blood God, is a mad slaughterer of men, with no thought for anything other than personal combat (at which, it must be granted, he excels).

### UNIQUE

Special characters can be either independent or upgrade characters, but each one of them is unique, so the player may not include multiples of the same special character in an army (for example, Marneus Calgar is the Master of the Ultramarines Chapter of Space Marines – you cannot field three of him!).

# PSYKERS

**Psykers are warriors gifted with awesome mental powers, which enable them to channel the baleful energy of the Warp.**

These powers vary from race to race and sometimes from one individual psyker to another. The psychic powers available to our models are not discussed further here, but are described in detail in the Codexes, where you will find complete rules for individual powers. The following general rules explain how psychic powers are employed. Exceptions to these rules are covered in the Codexes.

Psykers can use one psychic power per player turn. To use a psychic power successfully the psyker must pass a Psychic test, which is a normal Leadership test. Note that this test must always be made on the psyker's own Leadership value. Even where Leadership tests would normally be taken on the value of another model, tests for using psychic powers are always taken using the psyker's own Leadership.

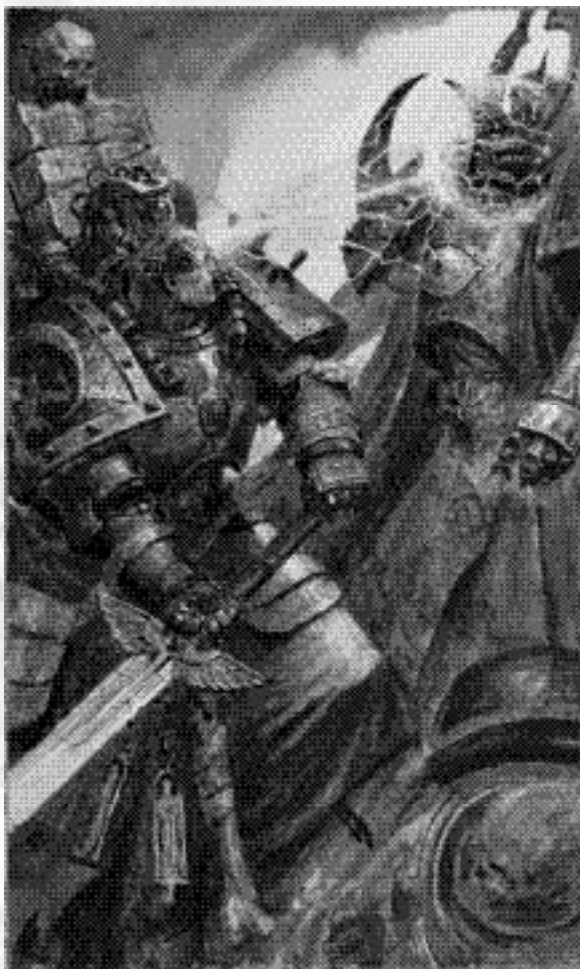

## PERILS OF THE WARP

If the result of a Psychic test is either a double 1 or double 6 this indicates that something horrible has happened to the psyker. The forces of the Daemon-haunted Warp claw at the psyker's mind and threaten to engulf and destroy him. The psyker suffers 1 wound with no armour or cover saves allowed. Invulnerable saves are allowed, but the power of the Warp is so great that successful saves must be re-rolled. Note that a psyker who rolls double 1 will still use his power, even if he is wounded or killed as a result.

## PSYCHIC SHOOTING ATTACKS

Psychic powers that take the form of shooting attacks are very common. Using a psychic shooting attack counts as firing a ranged weapon (an assault weapon, unless specified otherwise). So, for example, the psyker must be able to see his target unit, cannot be locked in combat, or must not have run in the Shooting phase if he wishes to use a psychic shooting attack. In the same way, if a psyker targets a unit with a psychic shooting attack, then he can only assault that unit in the ensuing Assault phase. Even if a psyker has a special rule allowing him to use more than one psychic power per turn, he can use only one psychic shooting attack (as models can fire only one ranged weapon per turn). However, if he is allowed to fire more than one ranged weapon per turn, he can replace the firing of any of the weapons he is allowed to fire with a psychic shooting attack (but still cannot use the same power twice in a turn).

## FORCE WEAPONS

Force weapons are potent psychic weapons used exclusively by trained psykers. They have the same effects as power weapons, but also confer to the wielder one additional psychic power, used in close combat, that can instantly extinguish the life force of any opponent.

Roll to hit and wound as normal, allowing any invulnerable saving throws the victim might have. The psyker may then take a Psychic test to use the weapon's power against any one opponent that suffered an unsaved wound by the weapon in that player turn. The normal rules for using psychic powers apply (remember that a psyker may normally use only one power per turn). If the test is passed, the enemy model suffers instant death, regardless of its Toughness value. This power has no effect against vehicles, models that are immune to instant death and any other model that does not have a Wounds value.

# UNIT TYPES

**The armies of the 41st Millennium are remarkably diverse and include many specialist warriors and exotic creatures.**

In this section, you will find the rules for each of these unit types, namely monstrous creatures, jump infantry, bikes & jetbikes, beasts & cavalry and artillery. Note that vehicles are also a different unit type, but they are so vastly different that they have an entire section of the rules devoted to them.

Except for the rules detailed in this section for each unit type, these units follow the same rules as infantry.

## MONSTROUS CREATURES

These terrifying monsters tower over their opponents, butchering all the enemies who face them and hurling tanks out of their path. Greater Daemons, Eldar Avatars and Tyranid Carnifexes count amongst their number.

### MOVEMENT

All monstrous creatures have the 'move through cover' special rule (see page 75). They simply bash their way through trees and ruins!

### SHOOTING

Instead of firing a single weapon, monstrous creatures can fire two of their weapons once per Shooting phase. They must, of course, fire both of them at the same enemy target. In addition, monstrous creatures have the 'relentless' special rule (see page 76).

Unless otherwise specified in their special rules, monstrous creatures cannot go to ground, voluntarily or otherwise. In addition, for a monstrous creature to be in cover, at least 50% of its body (as defined on page 16) has to be in cover from the point of view of the majority of the firing models. Also, standing in area terrain does not automatically confer a cover save to monstrous creatures – the 50% rule takes precedence. Cover for them works exactly as for vehicles (see page 62). As usual, if you cannot clearly tell if 50% of the model's body is covered, modify its cover save by -1.

### ASSAULT

All wounds inflicted in close combat by a monstrous creature ignore armour saves, just like those from a power weapon. In addition, monstrous creatures roll an additional D6 for armour penetration (2D6 + Strength) when attacking a vehicle in close combat.



## JUMP INFANTRY

Some special troops use devices that allow them to move at great speed across the battlefield, making them especially good at assaulting enemy troops and outflanking their positions. The Space Marines use jump packs, which utilise high powered controlled bursts from turbines to make bounding leaps across the field of battle, jumping over terrain with ease. Other races tend to have their own particular versions, such as Orks, whose Stormboyz use rudimentary 'rokkit packs' to close with the enemy, and Eldar, whose Swooping Hawks soar elegantly on light wings supported by gravitic motors. Sometimes the technology will be more exotic, such as that used by Eldar Warp Spiders, who utilise short-ranged teleport devices for a similar effect.

### MOVEMENT

Jump infantry can use their jump packs (or equivalent) and move up to 12" in the Movement phase. This is optional and they can choose to move as normal infantry if they wish. When using jump packs, they can move over all other models and all terrain freely. However, if a moving jump infantry model begins or ends its move in difficult terrain, it must take a dangerous terrain test. Jump infantry models may not end their move on top of other models or impassable terrain, except that they can end their move on top of impassable terrain if it is actually possible to place the models on top of it. If they do that, however, they treat the impassable terrain as dangerous terrain. All jump infantry units may enter the battle by 'deep strike', as explained on page 95.

### Fall back moves

Jump infantry fall back 3D6", because they always use their jump packs when doing this. They move over any terrain and models when falling back, but if they end their move in difficult terrain (or on top of flat impassable terrain) they must still take a dangerous

terrain test. They cannot end their move on top of other models, and must alter the direction of their fall back move as little as possible in order to avoid them, just as a normal unit would when falling back on foot. If they cannot do this, they are trapped and destroyed.

### SHOOTING

Jump infantry follow the same rules as infantry.

### ASSAULT

Jump infantry assault 6" like normal infantry. This move is slowed by difficult terrain in the same way as other infantry, because the unit always covers the last few yards of an assault on foot.

#### **Different Unit Types**

*So far the rules have just dealt with troops that move around on foot – infantry. This section covers different unit types, and these not only add new tactical elements to your games, but also more complexity to the rules. These unit types have different rules for the way they move, how terrain affects them, how far they can assault, and so on. You will find that Codexes often add even more changes and exceptions for specific models. In any given situation during a battle, if the Codex doesn't say any different, follow the rules for the appropriate unit type, and if those rules don't say anything different, follow the basic rules for infantry.*

*If you're just starting out, you may find it easier to use just infantry units in your first game or two, while you get used to the basic rules. On the other hand, if you do want to jump straight in, we suggest that you just read those unit type rules that apply to models in your collection.*

## JET PACKS

Some jump infantry are equipped with a special type of jump pack, referred to as a jet pack. Jet packs are designed to provide stable firing platforms rather than a means of getting into close combat. The most frequent users of this technology are the Tau. Jet packs differ from jump packs in the following ways:

- In the Movement phase, they only move 6" when using their packs, but are always allowed to move 6" in the Assault phase, even if they don't assault. When jet packers move in the Assault phase and do not assault, they treat difficult terrain just as other jump infantry do in the Movement phase.

- Models with jet packs have the 'relentless' special rule (see page 76).



## BIKES

Troops mounted on bikes excel at hit-and-run attacks. They are able to use their high speed to strike deep into enemy territory, complete their mission and escape before an enemy is able to react. A skilled commander will recognise the benefit of having bikes at his disposal, and is able to use them for advanced reconnaissance, as well as to outflank a slower enemy. Indeed, in open ground, bikes are easily capable of outrunning all but the fastest vehicles. Riding through heavy terrain can be somewhat dangerous however, but many riders take great pride in their superior driving skills and daring. These warriors are often regarded as dangerously hot-headed risk-takers, but their effectiveness cannot be denied.

### ADDITIONAL PROTECTION

Bikes are large, solid constructions, and are often fitted with protective armour and shields to deflect and absorb incoming fire. Bike riders benefit from the protection offered by their bike, which increases their Toughness characteristic by 1. Note that this increase does not affect the model's Toughness for the purposes of instant death (see page 26).

---

**Hope is the beginning of unhappiness.**

---

## MOVEMENT

Bikes can move up to 12" in the Movement phase. Bikes are not slowed down by difficult terrain. However, they treat all difficult terrain as dangerous terrain instead.

Bikes also have the 'turbo boosters' special rule (see page 76).

### Fall back moves

As bikes are so fast moving, they fall back 3D6", rather than 2D6". Remember that they treat all difficult terrain as dangerous.

## SHOOTING

Bikes cannot run in the Shooting phase.

Bikes have the 'relentless' special rule (see page 76).

Each bike in a unit may fire with one weapon for each rider on the bike. Thus a Space Marine Attack Bike with a driver and passenger in sidecar can fire two weapons.

## ASSAULT

Bike assault moves are not slowed down by difficult terrain. However, each model entering or moving through difficult terrain, or assaulting an enemy who is standing in difficult terrain or behind an obstacle, must take a dangerous terrain test.

## JETBIKES

Jetbikes are powered by anti-gravitational technology that allows them to hover a few metres above the ground and make powered boosts over obstacles. They are ideal for making raids on unsuspecting enemies, hitting hard and then using their superior speed and handling to escape.

Jetbikes are the same as bikes, with the following exceptions:

- In the Movement phase, jetbikes can move over all other models and all terrain freely. However, if a moving jetbike begins or ends its move in difficult terrain, it must take a dangerous terrain test. Jetbikes may not end their move over other models or impassable terrain, except that they can end their move on top of impassable terrain if it is actually possible to place the models on top of it. If they do that, however, they treat the impassable terrain as dangerous terrain.
- In the Assault phase, jetbikes are treated like normal bikes when assaulting, as they must move close to the ground in order to fight.

- When falling back, jetbikes move over any terrain and models, but if they end their move in difficult terrain (or on top of flat impassable terrain) they must still take a dangerous terrain test. They cannot end their move on top of other models, and must alter the direction of their fall back move as little as possible in order to avoid them, just as a normal unit would when falling back on foot. If they cannot do this, they are trapped and immediately destroyed.

### Eldar Jetbikes

The Eldar are the undisputed masters of anti-grav technology, and their jetbikes form swift moving attack forces that are justifiably feared by any who have faced them. Their favourite tactic is to suddenly emerge from cover, open fire and then dive back into cover before the enemy can retaliate.

All Eldar jetbikes (including Dark Eldar ones) are allowed to move 6" in the Assault phase, even if they don't assault. When Eldar jetbikes move in the Assault phase and do not assault, they treat difficult terrain in the same way as other jetbikes do in the Movement phase.



---

## BEASTS & CAVALRY

As well as squads of warriors fighting on foot, and the armoured bulk of vehicles, many armies of the 41st Millennium make use of fearsome predators and beasts, such as Warp Beasts and Flesh Hounds, to augment their forces. Other warriors ride to battle on horses, grunting boar-like monstrosities, daemonic steeds and countless other strange creatures. These unit types are referred to as 'beasts' if they have no rider, or as 'cavalry' if they do. They both, however, follow the rules given in this section.

When closing on their enemies, they are able to move at far greater speeds than warriors on foot, and as such are able to launch deadly charges and counter charges.

### MOVEMENT

Beasts and cavalry move like infantry.

### Fall back moves

Beasts and cavalry fall back just like infantry, except that they move 3D6" due to their speed.

### SHOOTING

Although beasts generally do not shoot, cavalry frequently can. They follow the same rules as infantry when they do so.

### ASSAULT

Beasts and cavalry have the 'fleet' special rule (see page 75).

Beasts and cavalry are capable of making an especially fast assault to charge their enemies. When assaulting they move up to 12".

If assaulting through cover, beasts and cavalry are slowed by difficult terrain – roll for the distance they can move just as you would for infantry, but double the result of the highest scoring dice.

Otherwise, they assault just like infantry.

---

**"I have seen war in all its forms.**

**I have seen feral world savages braining each other with stones, and I have seen the death of a whole planet at the hands of a virus bomb. I have seen Space Marines drop to certain death, and win. I have seen Titans crush whole platoons underfoot. But there is no more stirring sight in war than the charge of massed cavalry."**

Dravin Gratz

---

## ARTILLERY

Some weapons are so large and powerful that a single man could not hope to carry them by himself. They are more usually mounted on vehicles, but are sometimes utilised by infantry artillery teams, particularly if the battlefield's terrain is not suitable for vehicles. These mighty artillery weapons are mounted on wheeled supports or on anti-grav platforms, as they are simply too heavy to lug across a battlefield.

### THE UNIT

Artillery units consist of a number of crewman models and the gun models themselves. These units are quite complex as they include some vehicle models and some infantry models. The gun models are treated as vehicles with an Armour Rating of 10 (see the Vehicles section). Any glancing or penetrating hit will destroy a gun – do not roll on the Vehicle Damage table, the gun model is simply removed. If all the crewman models are killed, the guns are immediately removed as well.

Sometimes the player has the choice of adding leaders or additional models to the crew of an artillery unit. These models are part of the crew in all respects and may operate the guns as normal, even if they are otherwise slightly different from the rest of the crew. Independent characters that join the unit, however, do not count as crew and cannot operate the guns.

### MOVEMENT

Artillery units are slowed by difficult terrain like infantry, but gun models must also take dangerous terrain tests when they pass through it. There must be at least one crewman per gun to allow the unit to move – if there are fewer than this, then the unit may not move.

### SHOOTING

Unlike other vehicles (see next section), the gun models cannot fire if they moved at all in that turn's Movement phase. Any crewman that is within 2" of a gun in the Shooting phase can fire it. The crewman firing the guns may not fire any weapons they are carrying, while the other crew members (and any independent character that joined the unit) are free to fire their side arms, and can even shoot against a different unit than the one targeted by the unit's guns. The guns themselves cannot split fire. When firing the guns, there must be a line of sight to the target from both the gun model and the crewman firing it (unless they are barrage weapons, of course). Ranges are measured from the gun model.

When firing against an artillery unit, roll for each hit inflicted: on a 1-4 a gun is hit, on a 5-6 a crewman is hit. Roll to wound the crewmen and to penetrate the guns' armour separately.

If an artillery unit goes to ground, this has no additional protective effect on the unit's guns.

Artillery units cannot run in the Shooting phase.

## ASSAULT

Artillery units may not launch assaults as long as they include any gun models.

If they are assaulted, move the assaulting models in base contact with the crew and guns as normal, but from then on the guns are ignored. All engaged enemies roll to hit and to wound against the crew (even if they are only engaged with guns). Engaged crew models can of course fight back, but the guns do not.

## MORALE & FALL BACK MOVES

For the purposes of Morale and other Leadership tests, and for combat resolution, always ignore the gun models, as if they were not there. Because they need at least one crewman per gun in order for the unit to move, if an artillery unit does not have one crewman per gun when it is forced to fall back, the gun models without crewmen are abandoned and immediately removed. The rest of the unit then falls back as normal. If an artillery unit is forced to fall back from close combat and the enemy is free to make a sweeping advance, then the artillery unit automatically loses the Initiative roll and is caught and destroyed by the victor.

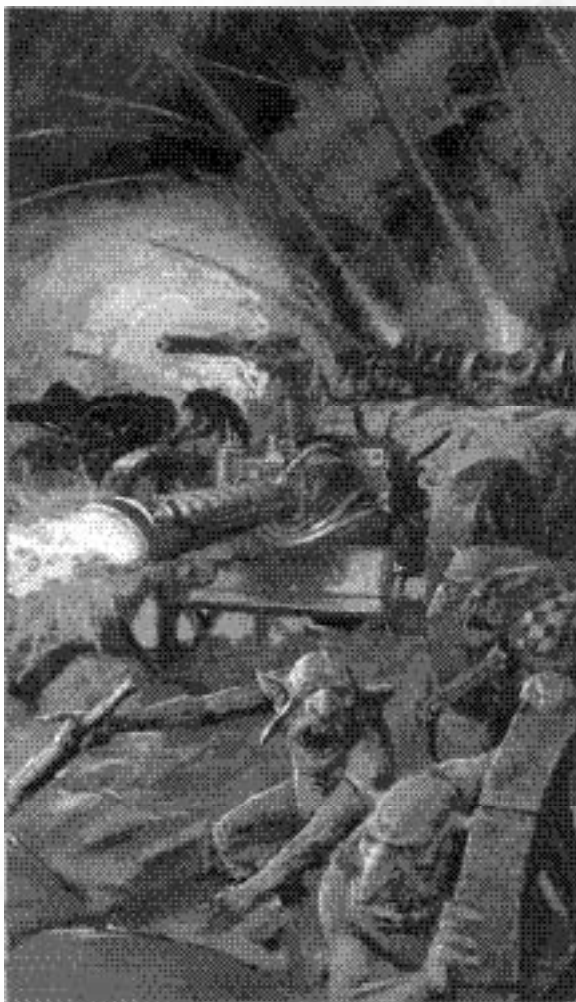

# VEHICLES

Because vehicles do not fight in the same manner as creatures of flesh and blood, their rules differ from other models in a number of ways, detailed here.

## VEHICLE CHARACTERISTICS

Vehicles have characteristics that define how powerful they are in a similar way to troops. However, their characteristics are different. Shown here is one example of a vehicle's profile:

Name	Type	Front Armour	Side Armour	Rear Armour	BS
Leman Russ	Tank	14	12	10	3

## TYPE

The different types of vehicle are: transport, tank, open-topped, fast, skimmer and walker. These types can be combined to define, for example, a fast skimmer or an open-topped walker, in which case the vehicle has all of the rules for all of its types.

The first part of this section presents the rules common to all vehicles. Then, each of the vehicle types has a separate entry, listing their unique rules and any exceptions to the normal vehicle rules (walkers being by far the most different).

## ARMOUR VALUE

The Armour Value of a vehicle tells you how hard it is to damage. Vehicles have separate Armour Values to represent the protection on their front, sides and rear. Armour Values typically range from 10 to 14, depending on which side of the vehicle is being attacked, usually with the lightest armour on the rear to represent vulnerable fuel tanks, engine compartments, etc.

## BALLISTIC SKILL

Vehicles have a BS value just like troops and it represents the accuracy of the crew as they blast away at their enemy with the vehicle's weapons.

## VEHICLES & MEASURING DISTANCES

As vehicle models do not usually have a base, the normal rule of measuring distances to or from the base cannot be used. Instead, for distances involving a vehicle, measure to or from their hull (ignore gun barrels, dozer blades, antennas, banners and other decorative elements).

There is however a notable exception, a vehicle's weaponry. When firing a vehicle's weapons, ranges are measured from the muzzle of the firing weapon, whilst line of sight is determined from the weapon's mounting point and along its barrel (as explained later).



## VEHICLES AND MOVEMENT

The distance a vehicle moves influences the amount of weapons it may fire and how easy a target the vehicle will be if assaulted, as described later.

- A vehicle that remains stationary will be able to bring its full firepower to bear on the enemy.
- A vehicle that travels up to 6" is moving at combat speed. This represents the vehicle advancing slowly in order to keep firing, albeit with reduced firepower.
- A vehicle that travels more than 6" and up to 12" is moving at cruising speed. This represents the vehicle concentrating on moving as fast as possible without firing its guns.

Moving a maximum of 12" may seem relatively slow for a vehicle, but it represents a cross-country speed rather than travelling on a road.

Vehicles can turn any number of times as they move, just like any other model. Vehicles turn by pivoting on the spot about their centre-point, rather than 'wheeling' round. Turning does not reduce the vehicle's move. This means that a vehicle may combine forward and reverse movement in the same turn providing it does not exceed its maximum move. Pivoting on the spot alone does not count as moving, so a vehicle that only pivots in the Movement phase counts as stationary (however, immobilised vehicles may not even pivot). Just like other units, vehicles cannot move over friendly models.

### **Crash, bang, wallop**

*One of the greatest pleasures to be had in the Warhammer 40,000 game is zooming vehicle models about the battlefield, unleashing the firepower of armoured behemoths and, conversely, blowing up those vehicles that belong to the enemy. The destruction of a vehicle is usually a spectacular event that can totally change the course of the game, and vehicle wrecks become important pieces of terrain unto themselves. But how best to represent such high-octane carnage?*

*Some like to demonstrate their vehicular misfortune by turning a destroyed tank onto its top or side. A few go even further and sculpt battle damage underneath the vehicle to complement this approach. However, many vehicles have delicate parts on top, so players often object to treating their beautifully-painted tanks in such a rough and ready manner, and adopt a different solution. We know several gamers who use cotton wool to represent the smoke billowing from destroyed vehicles, a visually pleasing solution and doubly handy if someone spills their tea.*

## TERRAIN EFFECTS

Vehicles attempting to move through broken terrain are not slowed down like other units, but risk becoming stuck, bogged down or damaged.

Vehicles are not slowed down by difficult terrain, but treat all difficult terrain as dangerous. Roll a D6 for every vehicle that has entered, left or moved through one or more areas of dangerous terrain during its move. A result of 2-6 on the dice means that the vehicle can carry on moving. A result of 1 means that the vehicle halts immediately and suffers an Immobilised damage result, so if it was attempting to enter difficult terrain it stops just outside.

When discussing terrain at the beginning of the game, it is perfectly fine for players to agree that some terrain has different effects on vehicles than it does on other units. For example, players may agree that tank traps are dangerous or even impassable to vehicles, but clear terrain for other units. Similarly, you could agree that vehicles (or just certain vehicle types) treat barbed wire as clear terrain, and so on.

### **ROADS**

Vehicles, with the exception of walkers and skimmers, that move at Cruising Speed following a road for their entire Movement phase may move up to an extra 6".

### **Battle damage**

*As you read on you will find that there are some damage results that debilitate rather than destroy vehicle models. Tanks can find themselves immobilised by a thrown track, have their weapon systems crippled or shot off altogether, or be stunned into inactivity for a turn. Marking these events is a little more difficult. Some players leave the weapons and turrets on their models unglued so that they can be carefully removed during battle. This helps with ease of transport and is a great way to represent Weapon Destroyed results – just take the relevant weapon off altogether.*

*A different approach is to place a dice on or next to the vehicle, showing the number that corresponds with the appropriate damage result. You could even invest in a set of damage markers. These have specific icons for each of the damage results, so you just need to place the relevant marker on or next to the vehicle when damage is inflicted. As with many aspects of the wargaming hobby, there is no 'right answer' – just make sure that your opponent is happy with whatever convention you decide upon.*

## VEHICLES SHOOTING

When a vehicle fires, it normally uses its own BS characteristic and shoots like other units – all its weapons must fire at a single target unit.

### MOVING AND SHOOTING VEHICLE WEAPONRY

The number of weapons a vehicle can fire in the Shooting phase depends on how fast it has moved in that turn's Movement phase, as detailed below.

In addition, the normal penalties of movement on shooting rapid fire and heavy weapons do not apply – when fired from a vehicle, these weapon types always fire as if the firing model had not moved, regardless of whether it actually did or not. Note that vehicles cannot run.

- Vehicles that remained stationary may fire all of their weapons (remember that pivoting on the spot does not count as moving).
- Vehicles that moved at combat speed may fire a single weapon (and its defensive weapons, as explained below).
- Vehicles that moved at cruising speed may not fire.

There are a few exceptions to these rules: ordnance, ordnance barrage, defensive and optional weapons.

#### Defensive weapons

Any vehicle weapons of Strength 4 or less (or with no Strength value) are classified as 'defensive' weapons.

A vehicle that moved at combat speed can fire all of its defensive weapons in addition to the single weapon it is usually allowed to fire.

#### Optional weapons

Some vehicles have, among the options of their army list entry, the possibility of buying additional weapons, such as one-shot missiles and pintle-mounted guns. Firing one of these additional weapons counts as firing one of the vehicle's normal weapons (unless they are defensive weapons, as described above).

#### Ordnance weapons

Firing a massive ordnance weapon requires the attention of all the gunners of the vehicle, so no other weapons may be fired that turn (not even defensive weapons!). In return, they are better at penetrating armour (see page 60). Unless their profile specifies otherwise, all ordnance blast weapons use the large blast marker.

---

**The Emperor asks only that you obey.**

---

#### Ordnance Barrage weapons

Differently from other unit types, vehicles carrying ordnance barrage weapons can choose to fire them either directly or as a barrage – declare before you fire.

If fired directly at the target, they are treated exactly like normal ordnance weapons (ignoring the minimum range in the weapon's profile).

Alternatively, the vehicle may fire these weapons as an ordnance barrage. In this case, the crew must carefully calculate the firing trajectory, so only vehicles that remained stationary may fire an ordnance barrage weapon (and may, of course, fire no other weapons that turn).

Just like normal barrages, ordnance barrages may have a minimum range (see their profile), they cause Pinning tests, and their targets work out their cover save as if the shot came from the centre of the blast marker. If fired at a target that is out of sight, the BS of the firer makes no difference and the blast marker scatters a full 2D6 if an arrow is rolled on the scatter dice. In addition, ordnance barrages are even more terrifying than normal ones – Pinning tests caused by ordnance barrages are taken with a -1 Ld modifier.

#### VEHICLE WEAPONS & LINE OF SIGHT

Just like infantry, vehicles need to be able to draw a line of sight to their targets in order to shoot at them. When firing a vehicle's weapons, point them against the target and then trace the line of sight from each weapons' mounting and along its barrel, to see if the shot is blocked by terrain or models. If the target unit happens to be in cover from only some of the vehicle's weapons, then work out if the target gets cover saves exactly as if each firing weapon on the vehicle was a separate firing model in a normal unit.

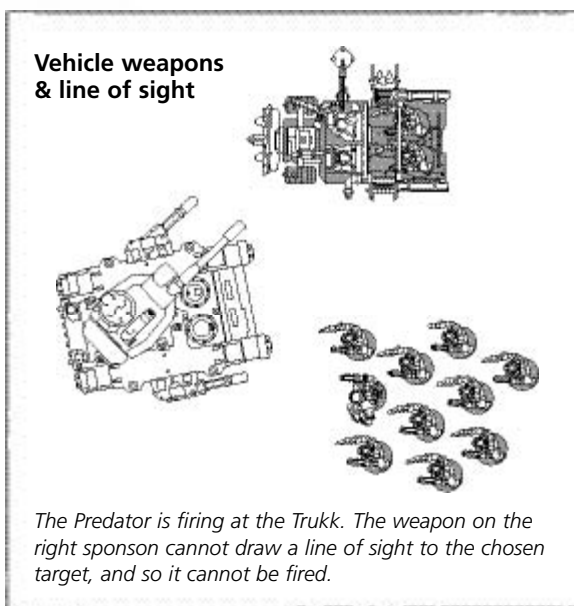

On some models it will be actually impossible to literally move the gun and point it towards the target, because of the way the model is assembled or because the gun has been glued in place. In this case, players should assume that the guns on a vehicle are free to rotate or swivel on their mountings. In order to make clear how much any gun is supposed to rotate, refer to the vehicle's entry, where each weapon has been classified as either turret-mounted, pintle-mounted (or 'bolt-on'), sponson-mounted or hull-mounted. Then apply the following guidelines:

- Turret-mounted weapons can usually rotate 360°, together with the entire turret, unless the design of the model prevents this.
- Hull-mounted weapons can fire in a 45° arc from their mounting point (see diagram).
- Sponson-mounted weapons vary greatly, as some can cover the full 180° of the flank they are mounted on (or even slightly more), while others are more limited. This is determined by the shape and position of the sponson's mounting (see diagrams).
- Pintle-mounted (or bolt-on) weapons can either fire in a 360° arc, if they are mounted on the vehicle's turret; or can fire in a 45° arc from their mounting point, if they are mounted on the vehicle's hull.

In the rare cases when it matters (your tank might be targeting a sniper high up in a bell tower), assume that guns can swivel vertically roughly by 45°, even if the barrel on the model itself cannot physically do that!

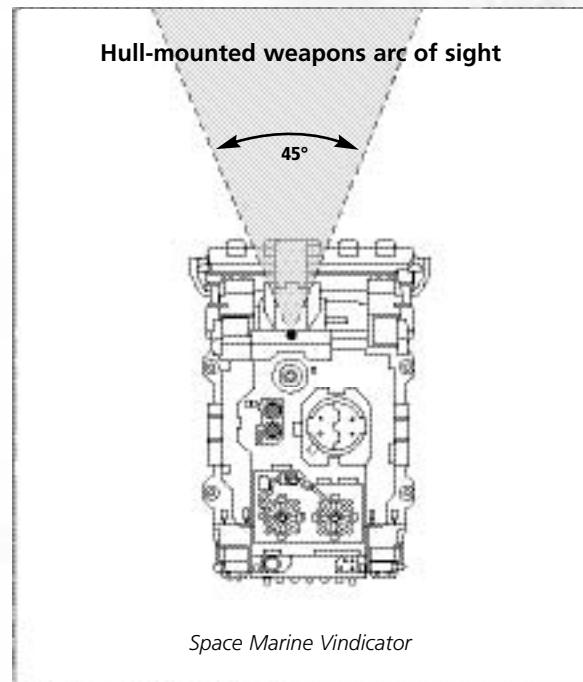
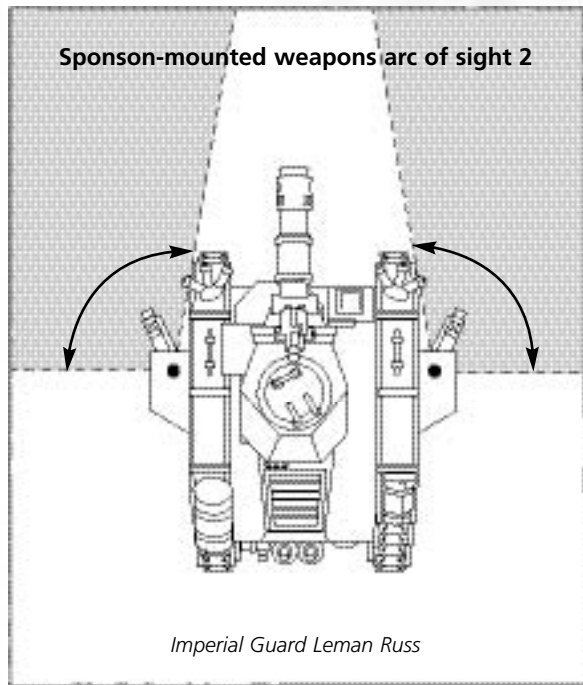
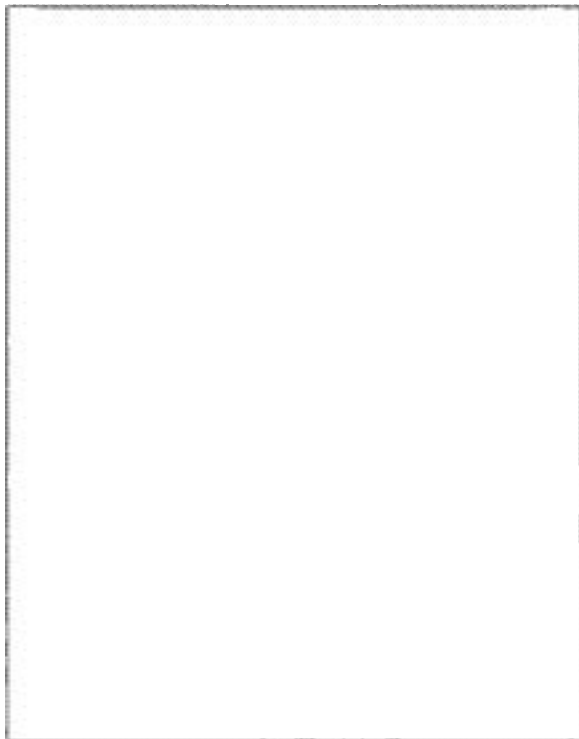

**“What I cannot crush with words  
I will crush with the tanks of the  
Imperial Guard.”**

*Lord Solar Macharius*

## SHOOTING AT VEHICLES

When a unit fires at a vehicle it must be able to see its hull or turret (ignoring the vehicle's gun barrels, antennas, decorative banner poles, etc.). As the whole unit must fire at the same target, often this means that some of their weapons can't damage the target vehicle, so we assume that the other members of the squad are providing covering fire, bringing forward ammunition for heavy weapons or simply keeping their heads down.

If the target vehicle is in range, roll to hit as normal. If any hits are scored, roll for each to see if they penetrate the vehicle's Armour Value, as explained next.

### VEHICLE FACING AND ARMOUR VALUES

Not all vehicles are equally armoured. Some massive tanks are protected by countless layers of reinforced adamantium and ceramite plates, while other lighter vehicles rely more on their speed to avoid incoming fire. As such, each different type of vehicle will have different Armour Values, representing not just the thickness and slope of its armour, but also how difficult a target it is because of its size and speed, how tough and numerous its crew are, and so on. Armour Values for individual vehicles also vary depending on which facing of the vehicle the shot comes from – its front, sides, or rear, as explained in the diagram.

If a unit has firing models in two different facings of a target vehicle (some models in the front and some in the side, for example), shots are resolved separately for the two facings.

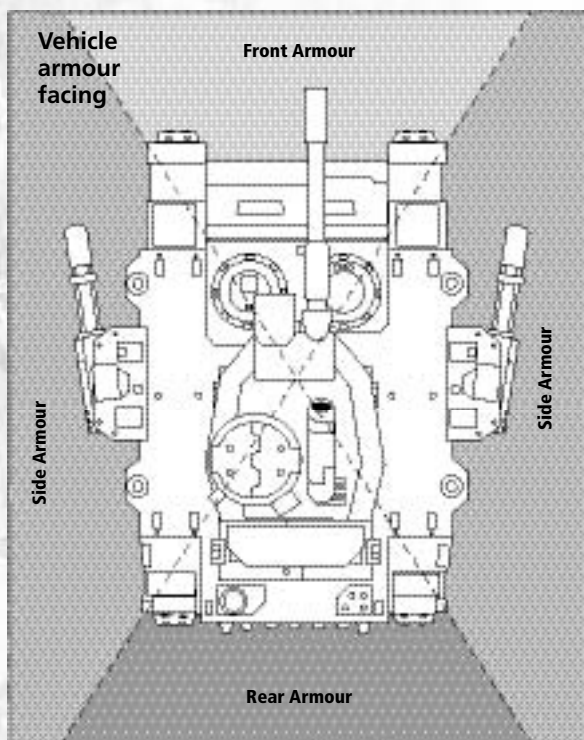

### ARMOUR PENETRATION

Hitting a vehicle is no guarantee that you will actually damage it. Once a hit has been scored on a vehicle, roll a D6 and add the weapon's Strength to it, comparing this total with the Armour Value of the appropriate facing of the vehicle.

- If the total is less than the vehicle's Armour Value, the shot has no effect.
- If the total is equal to the vehicle's Armour Value, the shot causes a glancing hit.
- If the total is greater than the vehicle's Armour Value, the shot scores a penetrating hit.

*Example: A lascannon shot hits the front of a Space Marine Predator (Armour Value 13). Rolling a D6, the player scores a 4, and adds this to the lascannon's Strength of 9, for a total of 13. Because this equals the Predator's Armour Value, it inflicts a glancing hit.*

### Ordnance weapons and Armour Penetration

Ordnance weapons (including Ordnance Barrage) hit with such force that the target's crew are turned to mush. When you roll to penetrate a vehicle's armour with an ordnance weapon, roll two dice instead of one and pick the highest result!

### Template and Blast weapons against vehicles

If a vehicle is even partially under a template weapon, it is hit on the Armour value the firer is facing.

When firing a blast weapon against a vehicle, place the marker with the hole over any part of the vehicle's hull and then roll for scatter as normal. In the case of multiple blasts, place the hole in the centre of the first marker on the vehicle's hull. If the markers scatter so that they're not over the vehicle at all, then obviously the vehicle is not affected. If a marker ends over the vehicle, it makes a big difference if the hole in the centre of the marker is over the vehicle or not:

- **The centre of the blast marker ends over the vehicle's hull.** In this case the shell or missile has hit the vehicle and exploded on it. The armour penetration roll is resolved against the Armour value facing the firer, regardless of the position of the marker, using the full Strength of the weapon. Hits from barrage weapons, however, always hit the vehicle's side armour (representing its top armour).
- **The centre of the blast marker ends outside the vehicle, but part of the marker covers its hull.** In this case the shell or missile has missed the vehicle, and only some shrapnel clanks against the vehicle's armour. The armour penetration roll is resolved against the Armour Value facing the centre of the marker, regardless of the position of the firer, and the weapon's Strength is halved (round down).

## DAMAGE ROLLS

A hit on a vehicle can have a variety of results. A vehicle's armour could be completely pierced, yet merely result in giving the crew a nasty shock. Alternatively, a lucky shot could detonate ammunition held within the vehicle, resulting in an explosion of titanic proportions. If a vehicle's armour is breached, you need to determine what damage is caused. Roll a D6 for each shot that glanced or penetrated the vehicle's armour, apply any appropriate modifiers (they are all cumulative) and look up the result on the Vehicle Damage table below.

### Glancing hits

If the shot has only caused a glancing hit, the damage to the vehicle will not be so severe. Apply a -2 modifier to the dice result.

### 'AP-' weapons

While some weapons are especially good at cutting through heavily armoured targets, others lack the penetrating power to destroy a vehicle easily. Penetrating and glancing hits inflicted by a weapon shown as 'AP-' suffer a modifier of -1 to the roll on the Vehicle Damage table.

### 'AP 1' weapons

Some weapons are so destructively powerful that they can penetrate a vehicle's heavily armoured hull with ease. If an AP 1 weapon, such as a multi-melta, scores a glancing or penetrating hit, add a modifier of +1 to the roll on the Vehicle Damage table.

### Other modifiers

Specific weapons and vehicles may have special rules that apply further modifiers to the damage roll. For example, hits on open-topped vehicles receive a +1 modifier, as explained on page 70.

## VEHICLE DAMAGE TABLE

D6	RESULT
1 or less	Crew – Shaken
2	Crew – Stunned
3	Damaged – Weapon Destroyed
4	Damaged – Immobilised
5	Destroyed – Wrecked.
6 or more	Destroyed – Explodes!

### Modifiers:

Glancing hit	-2
Hit by 'AP-' weapon	-1
Hit by 'AP1' weapon	+1
Target is open-topped	+1

## DAMAGE RESULTS

### 1 Crew – Shaken

The vehicle is rocked by the attack, but no serious damage is sustained (or perhaps the crew have decided that it is time to quickly relocate). The vehicle may not shoot until the end of its next player turn.

### 2 Crew – Stunned

The vehicle's crew is knocked about by the attack, or perhaps all of the vehicle's targeting and steering systems are temporarily scrambled (or maybe the crew have decided to temporarily bail out and take cover somewhere nearby). The vehicle may not move nor shoot until the end of its next player turn.

Note: Additional stunned and shaken results are not cumulative, so if a vehicle is shaken three times it is still only unable to fire in its next Shooting phase, not its next three Shooting phases!

### 3 Damaged – Weapon Destroyed

One of the vehicle's weapons (chosen by the attacker) is destroyed – ripped off by the force of the attack. If a vehicle has no weapons left, treat this result as an 'immobilised' result instead. This can include vehicle upgrades that function as weapons, such as pintle-mounted storm bolters or hunter-killer missiles.

### 4 Damaged – Immobilised

The vehicle has taken a hit that has crippled a wheel, track, grav plate, jet or leg. It may not move for the rest of the game. An immobilised vehicle may not turn in place but its turret may continue to rotate to select targets, and other weapons retain their normal arc of fire. Further 'immobilised' results count as 'weapon destroyed' instead.

Note: A vehicle that suffers either Damaged result when it has no weapons left and is already immobilised treats the result as 'Destroyed – Wrecked' instead.

### 5 Destroyed – Wrecked

The attack critically damages the hull and internal systems – the vehicle is destroyed. The model is left in place and becomes a wreck (see page 62).

### 6 Destroyed – Explodes

The vehicle is destroyed, as its fuel and ammo detonate, ripping it apart in a spectacular explosion. Flaming debris is scattered D6" from the vehicle, and models in range suffer a Strength 3, AP- hit. The vehicle is then removed and is replaced with an area of difficult ground representing scattered wreckage or a crater (if you have one).

Note: Vehicle drivers, gunners and other crew are killed if their vehicle suffers either Destroyed results.

## WRECKS

Wrecked vehicles are left on the table and effectively become a piece of terrain, counting as both difficult and dangerous terrain, and providing cover. Players must clearly mark that a vehicle has been wrecked in any way they consider suitable. For example, they can turn the vehicle or just its turret upside down (and not sideways to gain extra cover!), place a marker or cotton wool on it to represent smoke and flames, and so on.

## VEHICLES AND COVER – OBSCURED TARGETS

Vehicles do not benefit from cover in the same way as infantry – their sheer size and bulk mean they cannot take advantage of cover as well as infantry and other smaller, more agile troops. They can, however, position themselves in such a way as to make it harder for the enemy to hit them in a vulnerable location. The difference from the way cover works for other models is represented by the following exceptions to the normal rules for cover:

- At least 50% of the facing of the vehicle that is being targeted (i.e. its front, side or rear) needs to be hidden by intervening terrain or models from the point of view of the firer for the vehicle to claim to be in cover. If this is the case, the vehicle is said to be obscured (or 'hull down'). If a squad is firing at a vehicle, the vehicle is obscured only if it is 50% hidden from the majority of the firing models (do not count models that cannot hurt the vehicle). Just like with units of several models, if you're not sure whether the vehicle is 50% in cover or not, simply modify its save by -1.
- Vehicles are not obscured simply for being inside area terrain. The 50% rule given above takes precedence.
- Obviously, vehicles cannot go to ground, voluntarily or otherwise.

If the target is obscured and suffers a glancing or penetrating hit, it may take a cover save against it, exactly like a non-vehicle model would do against a wound (for example, a save of 5+ for a hedge, 4+ for a building, 3+ for a fortification, and so on). If the save is passed, the hit is discarded and no roll is made on the Vehicle Damage table.

If a special rule or a piece of wargear confers to a vehicle the ability of being obscured even if in the open, this is a 4+ cover save, unless specified otherwise in the Codex.

It may rarely happen that the firing unit cannot see any part of the facing they are in (front, side or rear), but they can still see another facing of the target vehicle. In this case they may take the shot against the facing they can see, but to represent such an extremely angled shot, the vehicle receives a 3+ cover save.

*Picture 1: more than 50% of the Rhino's side is hidden by the building – the Rhino is obscured.*

*Picture 2: less than 50% of the Rhino's side is hidden by the building – the Rhino is not obscured.*

## SMOKE LAUNCHERS

Some vehicles have small launchers mounted onto them that carry smoke canisters (or a more sophisticated equivalent in the case of some alien vehicles). These are used to temporarily hide the vehicle behind concealing clouds of smoke – especially useful when moving out into the open.

Once per game, after completing its move, a vehicle with smoke launchers can trigger them (it doesn't matter how far it moved). Place some cotton wool or other suitable marker on or around the vehicle to show it is obscured. The vehicle may not fire any of its weapons in the same turn as it used its smoke launchers, but will count as obscured in the next enemy Shooting phase, receiving a 4+ cover save.

After the enemy's Shooting phase, the smoke disperses with no further effect. Note that a vehicle may still use smoke launchers even if its crew are shaken or stunned.

It is worth pointing out that some armies might use different versions of smoke launchers, which have slightly different rules. As normal, the rules in the Codex take precedence.

## VEHICLES AND ASSAULTS

Vehicles can be both very dangerous and very vulnerable at close quarters. On one hand, massively armoured vehicles can scatter infantry before them, as no one in their right mind would wish to be caught beneath the tracks of an eighty-tonne tank bearing down on them! On the other hand, a stationary vehicle can often be very easily destroyed, as individuals clamber over it, attaching all manner of grenades and shooting into vulnerable spots.

### ASSAULTING VEHICLES

Infantry can pose a grave threat to vehicles if they get close enough. They can wreck a vehicle by shooting through vision slits, planting explosives on fuel tanks, tearing open hatches to attack the crew or committing some other equally imaginative act of mayhem.

#### Launching an assault

A unit can assault a vehicle in the Assault phase. The assault move is conducted just the same as assaulting other enemy units. As normal, all engaged models will attack.

#### Rolling to hit against vehicles

As the vehicle has no WS, the score needed for a hit depends on the speed of the target, as follows:

Target	D6 roll needed
Attacking a vehicle that is immobilised or was stationary in its previous turn.	Automatic hit
Attacking a vehicle that moved at combat speed in its previous turn.	4+
Attacking a vehicle that moved at cruising speed in its previous turn.	6

Note: when assessing how far a vehicle has moved, only take into account the actual distance covered from its original position. Moving backwards and forwards or driving around in circles does not help!

#### Armour penetration in close combat

Armour Penetration is worked out in the same way as for shooting (D6 + the Strength of the attacker). In close combat, however, all hits are resolved against the vehicle's rear armour, to represent the chance of attacking a vulnerable spot.

#### Combat results

Combats against vehicles are very different from those among other unit types. For a start, whilst vehicles can be assaulted, they cannot be locked in combat.

At the conclusion of a round of close combat against a vehicle there is no combat result, and so there are no sweeping advances, no pile-in and no consolidation moves. The vehicle and the enemy remain where they are and are free to simply move away in future turns. In a multiple fight including enemy vehicles and other unit types, the result of the fight is worked out as normal against the latter, ignoring the vehicles.

#### Successive turns

If a vehicle that has been assaulted, and has survived, does not move in its successive Movement phase, enemy models will still be in base contact with it during its Shooting and Assault phase. Enemy models that are in base contact with a vehicle are not locked in combat and can therefore be shot during the Shooting phase.

If the vehicle pivots on the spot (to shoot at its attackers for example), move these models out of the way as you shift the vehicle and then place them back into base contact with the vehicle.

Units that still have models in base contact with a vehicle in its Assault phase may attack it again, just as in a normal ongoing combat (including all models that would count as engaged in a normal assault).

## GRENADES

A well-placed grenade can often achieve a kill on a vehicle. Specialist tank-hunting troops are frequently equipped with Krak grenades (a special type of high-explosive grenade designed to stop vehicles in their tracks) or even melta bombs (fusion based charges that can reduce a battle tank to a burnt-out wreck in milliseconds).

Grenades have to be clamped or placed so as to inflict enough damage, so each model using them can only ever make one attack, regardless of the number of Attacks on their profile and any bonus attacks. Against vehicles, grenades have the following armour penetration:

Defensive and assault grenades	4+D6
Krak grenades	6+D6
Melta bombs	8+2D6

## VEHICLES AND MORALE

Vehicles never take Morale checks for any reason. It is assumed that in all cases the vehicle's crew has unshakeable faith in their vehicle and their orders. Any occasional lapses that do occur are represented by crew shaken and stunned results on the Damage table.

## UNITS OF VEHICLES – SQUADRONS

Most vehicles fight as individual units and are represented by a single model. However, some small vehicles, like Ork Warbuggies and Eldar Vypers, operate in units of more than one vehicle, known as squadrons. These follow the rules for normal units, with the following exceptions:

### MOVEMENT PHASE

When a squadron moves, all of its vehicles move at the same speed (i.e. they all move at combat speed, at cruising speed, etc.). All of its vehicles have to maintain coherency, just like ordinary units, but vehicles in a squadron need only to remain within 4" of each other to be in coherency, rather than within 2".

### SHOOTING PHASE

When shooting, a squadron of vehicles fires all of its available weaponry at a single enemy unit. Like other units, vehicles in squadrons can see and shoot through members of their own unit, just as if they were not there. This represents the vehicles manoeuvring around each other in a well-practiced battle formation.



When a squadron of vehicles is fired at, roll to hit and for armour penetration against the squadron's common Armour Value (which is normally the same for all facings, and in most cases is 10). If the vehicles in the squadron have different Armour Values on different facings, use the Armour Value of the facing of the closest visible vehicle.

Once all of the armour penetration rolls have been made, the player controlling the squadron allocates the glancing and penetrating hits to squadron members as he would allocate wounds to members of a normal unit. Then he takes any cover saves available to the squadron – use the rules for vehicles to determine if each squadron member is in cover (ignoring other members of the squadron, as if they were not there), and then the rules for normal units to work out if the entire squadron is in cover or not. After cover saves are taken, make the damage rolls for any remaining glancing and penetrating hits. The effects of damage results on vehicle squadrons are slightly different than on normal vehicles, as described below.

### DAMAGE RESULTS AGAINST SQUADRONS

The mutual support of vehicles in squadrons makes them resilient to damage results affecting the crew. On the other hand, the crews are under strict orders to abandon immobilised vehicles and disable them, not to leave them as spoils of war for the enemy.

To represent this, treat all immobilised results as destroyed (wrecked) and all stunned results as shaken. If a squadron consists of a single vehicle when an enemy unit fires at it, it reverts to the normal rules for vehicle damage results.

*For example, a squad of Space Marine Devastators opens fire against a squadron of three Eldar Vypers, scores several hits, and rolls for armour penetration against the squadron's Armour Value of 10. This results in three penetrating hits and three glancing hits. The Eldar player allocates two penetrating hits on one Vyper, two glancing hits on another and one penetrating and one glancing hit on the last Vyper. He then takes the cover saves for his Vypers (4+, for example), saving one of the glancing hits and one of the penetrating hits. Finally the opponent rolls for damage for the two glancing and two penetrating hits that are left, and the results are immediately applied on the Vypers that suffered them.*

### ASSAULT PHASE

When engaged in close combat against a squadron, enemy models roll to hit and for armour penetration against the squadron as a whole. Damage results have the same effect as described above, and are allocated against the squadron at each Initiative value, in the same way as a normal combat. As usual for combats against vehicles, there is no defenders' reaction, combat resolution, pile-in moves, consolidation, etc.

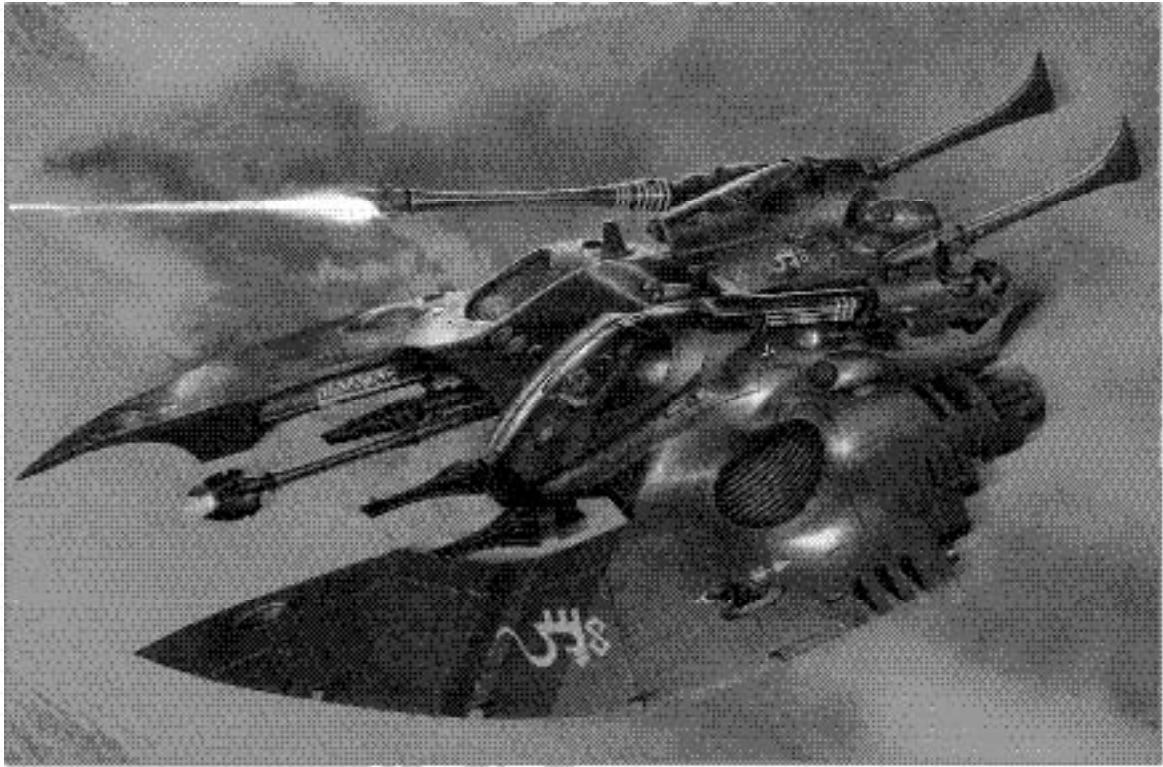

## VEHICLE TYPES

### Transport vehicles

Transport vehicles are designed to carry infantry squads around the battlefield. They offer to the warriors either the protection of an armoured hull to shield them from anti-personnel fire or a much higher movement speed, or might even combine both advantages, as in the case of Eldar transports.

### Tanks

Tanks are a common sight on the battlefields of the 41st Millennium. Most races field some kind of heavily armed and armoured vehicle, from the huge and lumbering Leman Russ battle tanks of the Imperial Guard, to the sleek and sophisticated grav-tanks of the Eldar. Tanks are often fitted for multi-role capability, which will commonly include troop transportation, tank-hunting and infantry support.

### Open-topped vehicles

Some vehicles are not fully enclosed, but expose their crews to a hostile universe. There are many reasons for this – to give reconnaissance units a clear field of vision, to make embarking and disembarking passengers easier, or it may simply be impractical to enclose the crew. While crews and embarked passengers on open-topped vehicles have more freedom of movement and better arcs of vision, the lack of an enclosed crew space inevitably means that the vehicle is more vulnerable to incoming fire.

### Fast vehicles

As the name suggests, fast vehicles are significantly quicker than most. Many fast vehicles are also skimmers, however, a few wheeled or tracked vehicles are also capable of high speeds, mostly due to either their light weight or extremely powerful engines. This type of vehicle has the additional advantage of being able to fire weapons while moving at higher speeds.

### Skimmers

While most vehicles travel across the ground on wheels, tracks or legs, some advanced machines are fitted with jets or anti-gravity drives that enable them to swoop and hover a few metres above the battlefield. This is not true flight, but rather a limited version of it. Often skimmers will also be categorised as fast vehicles but this is not always the case.

### Walkers

On any battlefield, there are places where conventional vehicles cannot go – built-up areas, dense forests, narrow tunnels, and so on. For this reason, many armies use vehicles that are propelled by two, or sometimes more, mechanical legs. These vehicles are usually capable of carrying as many weapon systems as a tank on a significantly smaller and lighter chassis. They combine the resilience of a tank with the manoeuvrability of an infantryman.

## TRANSPORT VEHICLES

Some vehicles can carry infantry across the battlefield, providing speed and protection. Of course if the transport is destroyed, the passengers risk being burnt alive in the explosion.

Transports have several additional characteristics: Transport Capacity, Fire Points and Access Points.

### TRANSPORT CAPACITY

Each transport vehicle has a maximum passenger capacity, which can never be exceeded.

A transport may carry a single infantry unit and/or any number of independent characters (as long as they count as infantry), up to a total of models equal to the vehicle's transport capacity. The entire unit must be embarked on a transport if any part of it is – a unit may never be partially embarked or spread across multiple transport vehicles.

Only infantry models may embark in transports (it is worth specifying that this does not include jump infantry), unless a Codex book states otherwise.

Some larger infantry models may count as more than one model for the purposes of taking up a transport's capacity, and this will be specified in the transporting vehicle's rules (for example, each Space Marine Terminator counts as two models).

Sometimes, there will be constraints on which types of models can embark on a particular vehicle, and this will be specified in the vehicle's entry. Space Marine Terminators, for example, cannot embark on a Rhino or Razorback, although they may be transported by a Land Raider.

### FIRE POINTS

A transport vehicle may have a number of fire points defined in its entry. A fire point is a hatch or gun slit from which one or more passengers inside the vehicle can fire (or use a psychic power).

Unless specified differently in the vehicle's entry, a single passenger may fire out of a fire point and the other transported models may not fire. Ranges and line of sight are measured from the fire point itself.

Models firing from a vehicle count as moving if the vehicle moves, and may not fire at all if the vehicle moved at Cruising speed that turn.

### ACCESS POINTS

Each vehicle capable of carrying passengers will have a number of access points defined in its entry. These are the doors, ramps and hatches that passengers use to get in and out of the vehicle. Models can embark or disembark within 2" of an access point.

## EMBARKING AND DISEMBARKING

Models can only voluntarily embark or disembark in the Movement phase, and may not voluntarily both embark and disembark in the same player turn. However, they may embark and then be forced to disembark if their transport is destroyed.

### Embarking

A unit can embark onto a vehicle by moving each model to within 2" of its access points in the Movement phase. The whole unit must be able to embark – if some models are out of range, the unit must stay outside. When the unit embarks, it is removed from the table and placed aside, making a note or otherwise marking that the unit is being transported (we find that placing one of the unit's models on top of the transport works well!). If the players need to measure a range involving the embarked unit (except for its shooting), this range is measured to or from the vehicle's hull.

- If the vehicle moved before its passengers got aboard, it may not move any further (including pivoting on the spot).
- If the vehicle has not moved before its passengers got aboard, it can move as normal.

---

## Only in death does duty end.

---

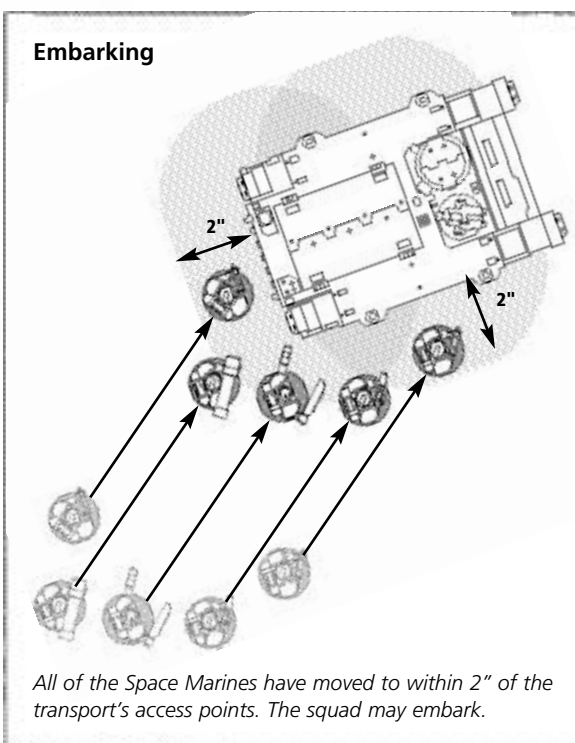

## Disembarking

A unit that begins its Movement phase aboard a vehicle can disembark either before or after the vehicle has moved. When the unit disembarks, each model is deployed within 2" of one of the vehicle's access points, and within unit coherency. Models cannot disembark within 1" of an enemy. If any models cannot disembark because of enemies or because they would end up in impassable terrain, the unit can perform an 'emergency disembarkation' – the models are deployed anywhere within 2" of the vehicle's hull, but the unit can't do anything else for the rest of the turn. If even this disembarkation is impossible, they can't disembark.

- If the vehicle has already moved (including pivoting on the spot), the passengers may disembark, but not move any further in that Movement phase. Once the models have disembarked, the vehicle may not move any further (including pivoting on the spot). After disembarking, these models may shoot (counting as moving), but may not assault.
- If the vehicle has not yet moved, then the passengers may disembark and move normally. The vehicle can also then move normally. The disembarked models may shoot (counting as moving), and may assault as normal.

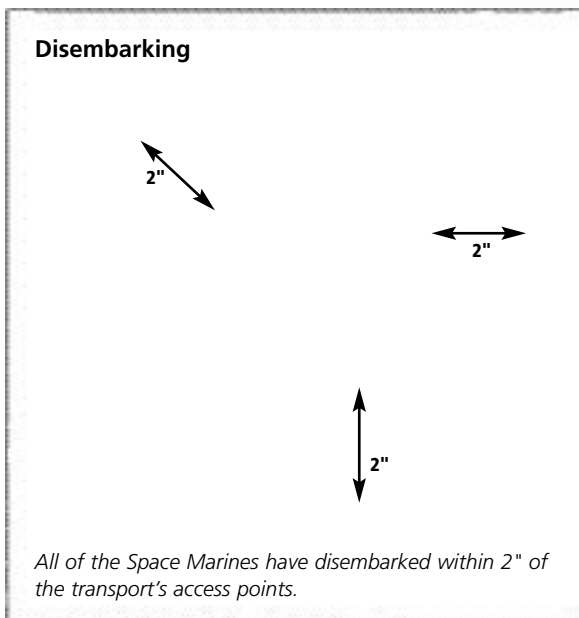

## Independent characters embarking and disembarking

If an independent character (or even more than one) and a unit are both embarked in the same vehicle, they are automatically joined, just as if the character was within 2" of the unit. If either an independent character or a unit is already in a vehicle, the other may join them by embarking too (assuming, of course, that there is enough space left).

The unit and the independent characters may, in a later Movement phase, disembark together as a single unit. They can also disembark separately by either the unit or the characters disembarking while the others remain onboard, or even disembarking at the same time using different access points (but they must end their move more than 2" away from each other). If the vehicle has yet to move, both unit and characters can disembark together and in coherency, but then the characters can leave the unit as they move, as normal.

## EFFECTS OF DAMAGE RESULTS ON PASSENGERS

### Crew shaken & crew stunned

Passengers may not shoot from the vehicle in their next Shooting phase, but are otherwise unaffected.

### Weapon destroyed & immobilised

These results have no effect on passengers.

### Destroyed – wrecked

The passengers must immediately disembark and then take a Pinning test. Any models that cannot disembark are destroyed. After this, the vehicle becomes a wreck.

### Destroyed – explodes!

The unit suffers a number of Strength 4, AP– hits equal to the number of models embarked, treated just like hits from shooting. The surviving passengers are placed where the vehicle used to be and then take a Pinning test.

Note: remember that all models in a single unit fire simultaneously, so a squad cannot take out a transport with its lascannon and then mow down the occupants with their bolters. However, if a transport is destroyed (either result) by a ranged attack, the unit that shot it may assault the now disembarked passengers, if it is allowed to assault according to the assault rules.

## DEDICATED TRANSPORTS

Sometimes a unit entry in a Codex will include a transport option, allowing a vehicle to be selected together with the unit. These 'dedicated transports' do not use up a slot on the force organisation chart. Other vehicles may also have a transport capacity, but they are chosen separately as normal and occupy a force organisation chart slot of their own (for example, the mighty Space Marine Land Raider).

The only limitation of a dedicated transport is that when it is deployed it can only carry the unit it was selected with (plus any independent characters). After the game begins, it can then transport any friendly infantry unit, subject to transport capacity and other special exclusions, as explained in the vehicle's entry (it might not be able to transport Terminators, for example).

## TANKS

Tanks are the most common vehicle type found on the battlefields of the 41st Millennium, where their armour and firepower are an invaluable asset for any army.

Tanks follow the normal rules for vehicles, with the additions and exceptions given below.

### TANK SHOCK!

Tanks may decide to use their mass as a weapon, driving right into and through densely packed enemies. This often throws the opposing battle line into disarray, as having some monstrous metal behemoth coming straight at you is unnerving for anybody.

When moving a tank, the player can declare that the vehicle is going to attempt to make a tank shock attack instead of moving normally. This is an exception to the rule that enemy models cannot be moved through.

Remember, though, that friendly models still cannot be moved through, so a tank shock cannot be attempted if friendly models are in the way. Also, tank shock cannot be attempted against enemy units that are locked in combat, as the risk of harming friends in the swirling melee is too high.

To make this kind of attack, first turn the vehicle on the spot in the direction you intend to move it and declare how many inches the vehicle is going to move. The vehicle must move at least at combat speed. Note that because pivoting on the spot does not count as moving, this is not enough for a tank shock.

Once the vehicle has been 'aimed' and the speed declared, move the vehicle straight forward until it comes into contact with an enemy unit or it reaches the distance declared – no other changes of direction are allowed during a tank shock. If no enemy unit is reached, just move the vehicle straight ahead for the distance declared and no special attack takes place.

If an enemy unit other than another vehicle is reached (including any model in an artillery unit), the unit must take a Morale check and will immediately fall back if it fails it. If the test is passed the unit will simply let the tank move through, as if it was not there. Regardless of the result of the test, the vehicle keeps moving straight on, possibly tank shocking more enemy units until it reaches its final position. If the tank accidentally moves into contact with a friendly model or comes to within 1" of an enemy vehicle, it immediately stops moving.

If some enemy models in the enemy unit would end up underneath the vehicle when it reaches its final position (it makes no difference whether the unit is falling back or not), these models must be moved out of the way by the shortest distance, leaving at least 1" between them and the vehicle and maintaining unit coherency.

If the tank moved slowly enough during the tank shock attack, it may fire as normal in the Shooting phase.

---

**My armour is contempt.**

---

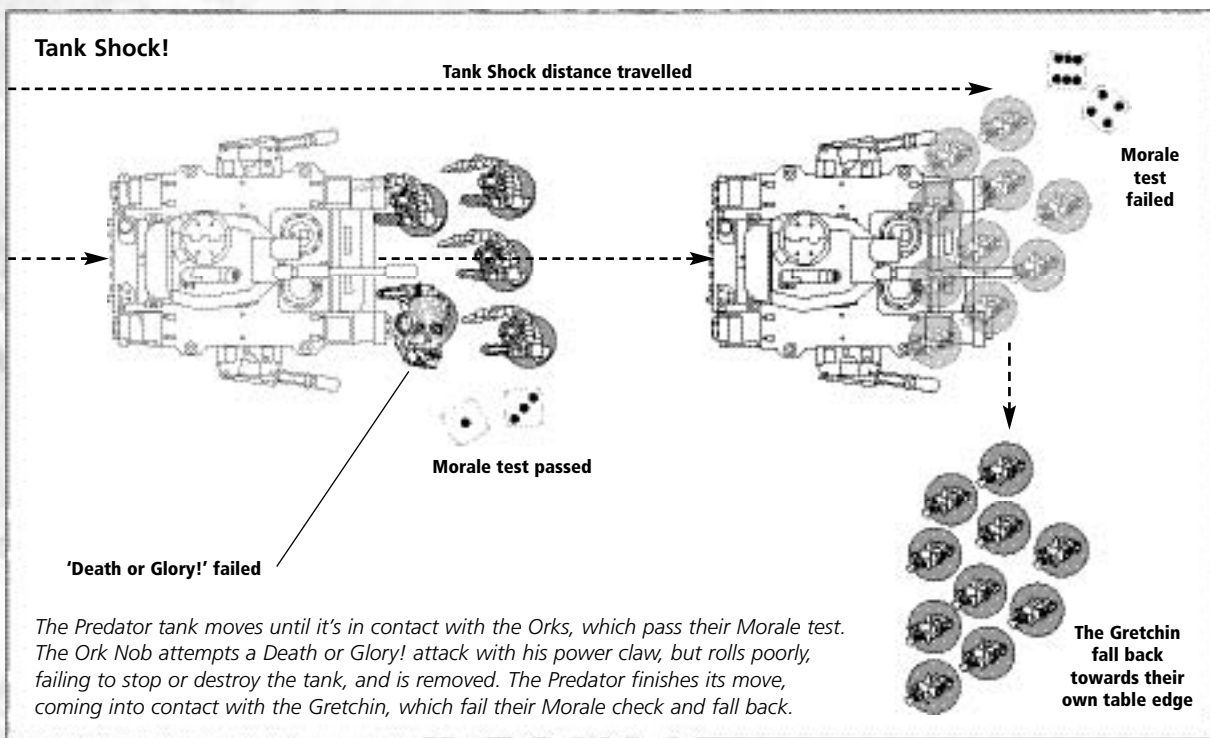

## Death or Glory!

If a unit that has been attacked by tank shock passes its Morale test, one of its models in the vehicle's path can stand and attempt to destroy it rather than move out of the way (this is potentially a rather suicidal thing to do!). The model nominated for this heroic duty makes a single attack against the incoming tank.

Even if the weapon used is assault 3, for example, or the model is normally allowed more than one attack, only one attack is ever resolved in this case. The attack can be either a shot from a weapon carried by the model, or a single close combat attack using any weapon carried, including grenades. Whatever form it takes, the attack hits automatically, so resolve the hit against the vehicle's front armour (using the front armour even if the model uses a close combat attack), and immediately apply any damage results.

If the model successfully managed to stun, destroy or immobilise it, the vehicle grinds to a halt directly in front of the heroic individual (or blows up there!).

If the attack fails to stop the vehicle, then the tank shock continues as normal, except that the brave (but perhaps rather foolish) glory seeker is crushed by the vehicle grinding over him – the model is removed, regardless of Wounds, saves (invulnerable or not), or any other clever way of staying alive they can think of.

Artillery units may attempt a Death or Glory! as well, with either a crewman (resolved as above) or a gun model. If a gun model does this and fails to stop the tank, both the gun and one crewman are removed.

## RAMMING

Ramming is a rather desperate manoeuvre and means that the tank must concentrate on moving at top speed towards one enemy vehicle. This means that it may not shoot in that turn's Shooting phase, making it an attractive choice for vehicles that have no armament left, or are shaken.

Ramming is a special type of tank shock move and is executed the same way, except that the tank must always move at the highest speed it is capable of. Units other than vehicles in the way of a ramming tank are tank shocked as normal. However, if the ramming tank comes into contact with an enemy vehicle, the collision is resolved as follows.

Each vehicle immediately suffers a hit against the armour facing where the other vehicle has impacted (so the rammer always uses its front armour). The Strength of the hits will often be different for different vehicles, and is calculated as follows for each vehicle:

- **Armour.** Each point of armour above 10 on the point of impact: +1
- **Speed.** Each full 3" moved that turn by the rammer before impact: +1
- **Mass.** If the vehicle is a tank: +1

*For example: a Land Raider rams an Ork Trukk, hitting it in the side. The Land Raider has a front armour of 14 (4 points over 10, for a total of +4), has moved 10" before reaching the Trukk (for an extra +3) and is a tank (+1). The total is 4+3+1, which means that the Trukk suffers a Strength 8 hit against its side armour. At the same time, the Land Raider suffers a Strength 3 hit against its front armour (+0 for the Trukk's side armour of 10, +0 because the Trukk is not a tank and +3 for the Land Raider's own speed).*

Both players roll for armour penetration against their enemy vehicle and any result is immediately applied. If the vehicle that is rammed is not removed, the rammer halts. However, if the rammed vehicle is removed because it suffers a 'destroyed – explodes!' damage result, the rammer continues its move, until it reaches its maximum move distance or another enemy (which it will tank shock or ram again!).

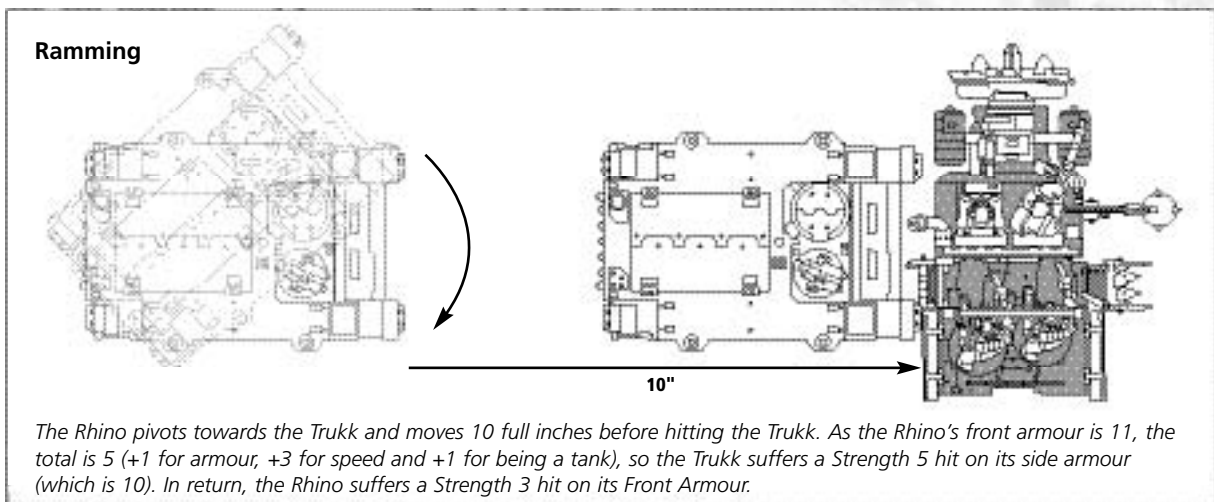

---

## OPEN-TOPPED VEHICLES

Some vehicles are much less armoured than tanks. This means they are more vulnerable to damage because of their lightweight construction and the fact that their crew is exposed to enemy fire. However, passengers can fire out and disembark much more easily than normal. Typical examples of open-topped vehicles are Ork Trukks and Dark Eldar Raiders. Open-topped vehicles follow the normal vehicle rules, with the additions and exceptions given below.

### OPEN-TOPPED TRANSPORT VEHICLES

Open-topped vehicles do not have specific fire points. Instead, all passengers in an open-topped vehicle may fire, measuring range and line of sight from the hull of the vehicle. Open-topped vehicles do not have specific access points. Models can embark or disembark within 2" of any point of the vehicle. The passengers of open-topped vehicles may assault, even if the vehicle has moved before their disembarkation. As it is much easier to bail out from an open topped transport, the Strength of hits inflicted on passengers by exploding open topped transports is one point lower than it would be in a normal transport (i.e. Strength 3).

### DAMAGING OPEN-TOPPED VEHICLES

Whenever a damage roll is made against an open-topped vehicle, add +1 to the result.



---

## FAST VEHICLES

Some vehicles are markedly faster than the more ponderous tanks, because of the combination of their lighter construction and more powerful engines.

Fast vehicles follow the normal rules for vehicles, with the additions and exceptions given below.

### MOVING FAST VEHICLES

Fast vehicles are capable of a third level of speed, called 'flat out'. A fast vehicle going flat out moves more than 12" and up to 18". This represents the fast vehicle moving at top speed, without firing its guns and is treated in all respects exactly the same as moving at cruising speed for a vehicle that is not fast (except where noted otherwise). For example, a fast vehicle moving flat out on a road may move up to 24".

### FAST VEHICLES FIRING

Fast vehicles may move and fire more effectively than other types of vehicles.

Fast vehicles that move at combat speed may fire all of their weapons, just like other types of vehicles that have remained stationary (including ordnance barrage weapons, which cannot usually be fired on the move).

Fast vehicles that move at cruising speed may fire a single weapon (plus all defensive weapons, just like other types of vehicle moving at combat speed).

Fast vehicles moving flat out may fire no weapons.

### ASSAULTING FAST VEHICLES

Fast vehicles that moved 'flat out' in the previous turn and are not immobilised are hit on a 6 in assaults (exactly as if moving at cruising speed).

### FAST TRANSPORT VEHICLES

Passengers may not embark onto or disembark from a fast vehicle if it has moved (or is going to move) flat out in that Movement phase.

---

**"Why do we ride atop these elegant craft? The better to hear the screams of our prey as we ride them down, to savour the fear etched on their faces, to taste the tantalising tang of their blood in the air as an appetiser before the feast. But most of all we ride them so that the slaughter may begin as soon as possible."**

*Dhariaq Bladetongue, Kabal of the Pierced Eye*

---

---

## SKIMMERS

---

Some highly advanced vehicles are fitted with anti-gravity drives that allow them to skim swiftly over rough terrain and intervening troops.

Skimmers follow the normal rules for vehicles, with the additions and exceptions given below.

### MEASURING DISTANCES

Unlike other vehicles, skimmers have transparent 'flying bases' under their hull. As normal for vehicles, distances are measured to and from the skimmer's hull, with the exceptions of the vehicle's weapons, access points and fire points, which all work as normal. The skimmer's base is effectively ignored, except when assaulting a skimmer, in which case models may move into contact with the vehicle's hull, its base or both.

### MOVING SKIMMERS

Skimmers can move over friendly and enemy models, but they cannot end their move on top of either. Note that a skimmer must be set down on the table and left in place at the end of its move – it cannot be left hovering in mid-air!

Skimmers can move over all terrain, ignoring all penalties for difficult terrain and tests for dangerous terrain. However, if a moving skimmer starts or ends its move in difficult or dangerous terrain, it must take a dangerous terrain test. A skimmer can even end its move over impassable terrain if it is possible to actually place the model on top of it, but if it does so it must take a dangerous terrain test.

A skimmer that is also fast and is moving flat out can move up to 24".

### SHOOTING AT SKIMMERS

Skimmers moving at high speed are very difficult to hit. A skimmer that is not immobilised and has moved flat out in its last Movement phase counts as obscured (cover save of 4+) when fired at.

On the other hand, having your engines stall when flying at high speed has its consequences, so a skimmer that is immobilised immediately crashes and is destroyed (wrecked) if it moved flat out in its last turn. If it moved slower, it suffers an immobilised result as normal.

If a skimmer is immobilised or wrecked, its base is removed, if possible. If this is not possible (the base might have been glued in place, for example), don't worry about it. The skimmer's anti-grav field is obviously still working and an immobilised skimmer will simply remain hovering in place, incapable of any further movement (including turning on the spot); a wrecked one is now a floating, burning wreck. Note that it is not permitted to remove the flying stand other than in the two cases above, as normally skimmers cannot land in battle conditions.

## RAMMING A SKIMMER

Skimmers may try to dodge out of the way of tanks attempting to ram them (as long as the ramming tank is not also a skimmer). The ramming tank stops in contact with the skimmer as normal, but then, if the player controlling the skimmer wants to dodge, he rolls a D6. On a 1 or 2 the collision proceeds as normal. On a 3+ the skimmer avoids the tank, neither vehicle suffers any damage, and the ramming tank stops in its tracks (literally!), its crew confused and disappointed.

---

**"Listen not for the approach of the Eldar, nor look to the skies for their coming. Their craft are silent as midnight, swift as dawn, and bring naught but death to the enemies of that forlorn race."**

*Inquisitor Czevak, Admonitions and Portents*

---



## WALKERS

Walkers are a very unusual type of vehicle. Instead of wheels or tracks they have mechanical limbs that allow them to stride forward, ploughing through densely packed terrain with ease in order to bring their weapons to bear. Because of this they use some of the rules for normal infantry.

### ADDITIONAL CHARACTERISTICS

Walkers have a Weapon Skill, Strength, Initiative and Attacks value, representing their ability in close combat and reaction speed, in the same way that they do for models that aren't vehicles. Shown here is an example:

	Type	Armour							
		WS	BS	S	F	S	R	I	A
Dreadnought	Walker	4	4	6	12	12	10	4	2

### MEASURING RANGES

If a walker has a base, measure ranges and distances to and from its base, as you would for an infantry model. If a walker does not have a base (like the Chaos Defiler), measure to and from its hull (including its legs and other limbs), as normal for vehicles. Firing the walker's own weapons is an exception to this, as explained later on this page.

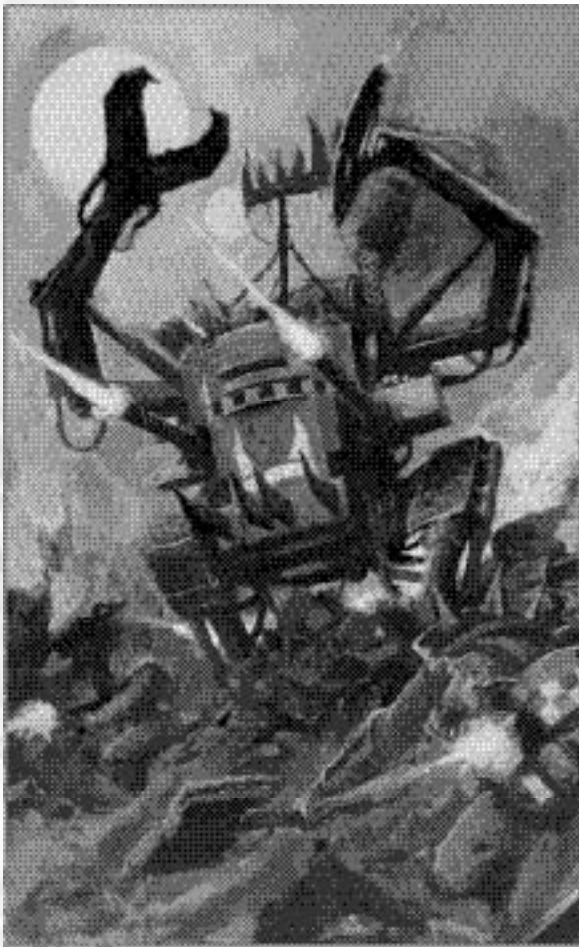

## MOVING WALKERS

While other vehicles can only move in the Movement phase, walkers can also run in the Shooting phase and assault in the Assault phase, just as infantry can.

Walkers move in exactly the same way as infantry, so they can move up to 6" in the Movement phase and assault up to 6" in the Assault phase.

Difficult terrain affects walkers just as it does infantry. Difficult terrain only counts as dangerous terrain for walkers if it would do so for infantry. If walkers fail a dangerous terrain test, they are immobilised.

Unlike infantry, a walker has a facing, which influences where it can fire (see below) and its Armour Value when fired at.

## WALKERS SHOOTING

Walkers can move and fire all of their weapons, just like a stationary vehicle.

Alternatively, they can choose to run like infantry, and this prevents them from firing and assaulting that turn, as normal (though they can still trigger their smoke launchers, if they have any). Obviously they cannot run if they are stunned or immobilised.

When firing a walker's weapons, pivot the walker on the spot so that its guns are aimed at the target (assume that all weapons mounted on a walker can swivel 45°, like hull-mounted weapons) and then measure the range from the weapon itself and line of sight from the mounting point of the weapon and along its barrel, as normal for vehicles. This pivoting in the Shooting phase does not count as moving and represents the vastly superior agility of walkers in comparison with other vehicles. Keep in mind however that the walker will probably remain facing in this direction until its next Movement phase, so its facing will determine where its rear armour is going to be when the enemy returns fire!

## SHOOTING AT WALKERS

When firing at a walker, work out which of its Armour Values to use as you would for any other vehicle, based on the position of its body. Walkers that are locked in combat cannot be shot at.

---

**"We pray for our brethren who pilot the Dreadnoughts. Though they take new form, their souls, and their weapon mounts, remain pure."**

**Marneus Calgar**

---

## WALKERS AND ASSAULTS

Walkers assault like infantry models, meaning that they make assault moves and can be locked in combat with enemy units. Walkers can make an assault even if they fired heavy or rapid fire weapons. However, like normal infantry, they can still only assault the unit they fired at.

In close combat, walkers fight like infantry models. However, any hits scored against them must roll for armour penetration and damage as for a vehicle. Models hitting a walker in close combat always roll for penetration against its front armour. This is because the walker is not a static target like other vehicles and rampages through the melee, turning to face its enemies. Consequently a walker is quite capable of tearing apart its foe in close combat, while only the specially armed (or monstrosly powerful) will have any hope of destroying a walker up close.

Grenades and melta bombs can be used against a walker. A model will only manage to score a hit with a grenade against a walker on the roll of 6. However, if a walker is already stunned or immobilised at the start of the Assault phase, the attackers roll to hit based on the normal comparison of WS. Remember that models using grenades against vehicles only make one attack.

Immobilised and/or stunned walkers fight in close combat with one less attack than usual (to a minimum of 1), but otherwise attack normally, no matter how many immobilised and stunned results they suffered.

Shaken damage results do not affect the way a walker fights in close combat.

Each roll made on the Vehicle Damage table against a walker counts as a single wound for the purposes of working out who won the combat.

Defeated walkers do not take Morale checks and are not affected by the No Retreat! rule.

Walkers make sweeping advances, pile-in moves and consolidations unless they are stunned or immobilised.

## RAMMING A WALKER

If a walker is rammed by a tank, it can choose to either brace itself for the impact, in which case the collision is resolved as normal for a vehicle, or it can attempt a 'Death or Glory!' attack in the same way as infantry (it cannot do this, however, if it is rammed in its rear arc).

If it chooses 'Death or Glory!' and its attack fails to stop the ramming tank, the walker will not be ready for the impact and is hit on its rear armour in the collision.

## SQUADRONS OF WALKERS

Squadrons of walkers follow all normal rules for vehicle squadrons, except in assaults. They assault and react to being assaulted in the same way as units of infantry, moving to engage their attackers before attacks are rolled. Damage results are resolved as described for vehicle squadrons, however, and they attack back, perform sweeping advances, pile-in moves and consolidations like walkers (see Walkers and Assault).

### DREADNOUGHT CLOSE COMBAT WEAPONS

Walkers are often armed with huge close combat weapons – hammers, wrecking balls, claws, etc. A Dreadnought close combat weapon is a power weapon and doubles the walker's Strength in close combat (up to a maximum of 10).

If the walker suffers a weapon destroyed result and the player chooses the close combat weapon, the walker loses the bonuses conferred by the Dreadnought close combat weapon (and any other weapon built into the same arm).

If a walker is armed with two or more close combat weapons, it gains one bonus attack for each additional weapon over the first. If one of its additional weapons is destroyed, one bonus attack is lost.

## VEHICLE MOVING & SHOOTING SUMMARY CHART

	Stationary	Combat Speed	Cruising Speed	Flat Out
<b>All (except Fast &amp; Walkers)</b>	All Weapons	1 Weapon*	No Weapons	N/A
<b>Fast</b>	All Weapons	All Weapons	1 Weapon*	No Weapons
<b>Walker</b>	All Weapons	All Weapons	N/A	N/A

\*plus all defensive weapons.

# UNIVERSAL SPECIAL RULES

Many units of models in Warhammer 40,000 have unique special rules. There are, however, quite a few special rules that are shared by several units, even across different Codex books. These are called 'universal special rules' and are listed in this section for ease of reference.

As this is just a summary, if any of the Codexes include one of these special rules and the rule is different, the one in the Codex takes precedence (representing how the general special rule applies to that specific race).

The special rules marked with an asterisk (\*) are automatically lost by an independent character joining a unit that does not have the same special rule. These rules are also lost by a unit that is joined by an independent character that does not have the same special rule.

## COUNTER-ATTACK

Troops with this skill believe that attack is always the best form of defence. If assaulted, they will spring forward themselves and ferociously counter-attack the charging enemy.

To represent this, when a unit with this rule is assaulted by the enemy it must take a Leadership test. If the test is successful all models in the unit get the +1 assault bonus to their attacks, exactly as if they too had assaulted that turn.

This rule cannot be used if, when assaulted, the unit was already locked in combat from a previous turn.

## ETERNAL WARRIOR

The model is immune to the effects of the Instant Death rule.



## **FEARLESS**

Fearless troops automatically pass all Morale and Pinning tests they are required to take, and will never fall back. They can however go to ground voluntarily. This special rule is gained by any independent character joining a fearless unit. However, as long as a fearless character stays with a unit that is not fearless, he loses this special rule. If a unit that is falling back suddenly gains this rule, it will automatically regroup at the beginning of its next Movement phase, regardless of all normal restrictions on regrouping.

## **FEEL NO PAIN**

Some warriors are so blood-frenzied or tough that they can ignore injuries that would incapacitate even a battle-hardened Space Marine. If a model with this ability suffers an unsaved wound, roll a dice. On a 1, 2 or 3, take the wound as normal (removing the model if it loses its final Wound). On a 4, 5 or 6, the injury is ignored and the model continues fighting. This ability cannot be used against wounds from weapons that inflict instant death (by having a high enough Strength or a special rule to that effect; even if the model is an eternal warrior). Neither can it be used against wounds from AP1 and AP2 weapons, power weapons and any other wound against which no armour save can ever be taken (like wounds from power fists, Dreadnought close combat weapons, rending weapons that roll a 6, Perils of the Warp, failed dangerous terrain tests, etc).

## **FLEET\***

There are many variants of this rule: Fleet of Foot, Fleet of Claw, even Fleet of Hoof. Title aside, all models with these abilities are treated the same. A unit with this rule may assault in the same turn in which it has run.

## **FURIOUS CHARGE**

Models with this skill are known for the wild ferocity of their assaults. In a turn in which they assaulted into combat they add +1 to both their Initiative and Strength characteristics when attacking in close combat (note that this has no effect on the Initiative tests for sweeping advances).

## **HIT & RUN\***

Units with this ability that are locked in combat may choose to leave close combat at the end of the Assault phase. The unit using the hit & run ability must take an Initiative test. If the test is failed nothing happens and the models remain locked in the fight. If the test is passed, the unit breaks from combat and immediately moves up to 3D6" in a straight line in any direction, ignoring the units they are locked with. No sweeping advance rolls are made. Enemy units that are no longer locked in combat may consolidate. A hit & run move is not slowed by difficult terrain, but is affected by

dangerous terrain. It may not be used to move into contact with the enemy. If there are units with this rule on both sides, roll-off to determine who goes first and then alternate disengaging them. If the last of these ends up no longer in combat, it consolidates instead.

## **INFILTRATE\***

In the right circumstances, stealthy troops have the ability to work their way into a forward position on the battlefield or outflank enemy lines.

Units with this special rule are deployed last, after all other units (friends and foe) have been deployed. If both sides have infiltrators, the players roll-off and the winner decides who goes first, and then alternate deploying these units. Infiltrators may be set up anywhere on the table that is more than 12" from any enemy unit, as long as no deployed enemy unit can draw a line of sight to them. This includes inside a building (see page 83), as long as the building is more than 12" from any enemy unit. Alternatively, they may be set up anywhere on the table that is more than 18" from any enemy unit, even in plain sight.

If a unit with this ability is deployed inside a transport vehicle, it cannot infiltrate. Infiltrate also confers a special outflank move to units of infiltrators that are kept in reserve (see page 94).

## **MOVE THROUGH COVER\***

Some units of infantry are especially adept at moving through difficult terrain. Units with this rule roll an extra D6 when rolling to move through difficult terrain. In most circumstances this will mean that they roll three D6 and pick the dice with the highest score.

## **NIGHT VISION/ACUTE SENSES**

Warriors in certain parts of the galaxy have developed nocturnal tendencies by fighting in perpetual night, or perhaps carry equipment that gives them such abilities. When the Night Fighting mission special rule is in use, such models may choose to re-roll the test to determine how far they can see, but must abide by the new result. Characters with this rule confer it onto any unit they join, as long as they are part of the unit. Units with this rule confer it onto any characters joining them, as long as they are part of the unit.

## **PREFERRED ENEMY**

Some warriors are able to predict the moves of the enemies they are used to fighting. In close combat, they have developed special techniques that enable them to counter such enemies more effectively. Such troops can always re-roll their rolls to hit in close combat against their preferred enemy. This ability does not work when attacking vehicles without a Weapon Skill characteristic.

## **RAGE**

Some warriors are little more than mindless killing machines, incapable of rational thought and only interested in getting to grips with the enemy as soon as possible. In the Movement phase, units subject to rage must always move as fast as possible towards the closest visible enemy. In the Shooting phase, they are free to decide whether to run, but if they do they must run towards the closest visible enemy. In the Assault phase they must always consolidate towards the closest visible enemy. Whilst falling back, embarked on a transport, or if no enemy is visible, they ignore this rule.

## **RELENTLESS**

Unlike common infantry, some powerful warriors like monstrous creatures, jet packers and bikers can advance while firing their weapons at full capacity. Relentless models can shoot with rapid fire and heavy weapons counting as stationary, even if they moved in the previous Movement phase, and are also allowed to assault in the same turn they fire them.

Note that a relentless independent character must still abide by the assaulting limitations of any unit it has joined, if the unit is not itself relentless.

## **SCOUTS\***

Scouts are used to reconnoitre ahead and are always in the vanguard of the army. To represent this, after both sides have deployed (including infiltrators), but before the first player begins his first turn, any scouts may make a normal move. This is done exactly as in their Movement phase, except that during this move, scouts must remain more than 12" away from any enemy.

If both sides have scouts, the players roll-off and the winner decides who goes first, and then alternate moving these units.

If a unit with this ability is deployed inside a dedicated transport vehicle, it confers the scout ability to the transport too.

This rule also confers a special outflank move to units of scouts that are kept in reserve (see page 94).

## **SKILLED RIDER**

The rider is highly practiced at moving through perilous warzones. It may re-roll the dice for failed dangerous terrain tests as long as its unit type is bike or cavalry.

## **SLOW AND PURPOSEFUL**

Models with this special rule are relentless (see above). However, they always count as moving through difficult terrain (including in assaults). Remember that a slow and purposeful independent character will cause any

unit he joins to move at his speed (and vice versa) as units have to move at the speed of the slowest model.

## **STEALTH**

The ability to make maximum use of available cover has saved many a warrior from discovery and death. All of the unit's cover saves are improved by +1.

## **STUBBORN**

Stubborn resistance against impossible odds is a feature of some races. When taking Morale tests, stubborn units always ignore any negative Leadership modifiers. Independent characters that are stubborn confer the ability onto any unit that they join.

## **SWARMS**

Swarms represent creatures that are too puny to be an individual threat on the battlefield, but when operating as a sea of dozens of creatures they can destroy much larger enemies. All swarms have the 'stealth' and 'vulnerable to blasts/templates' special rules. In addition, intervening swarms never offer any cover save to monstrous creatures or vehicles.

## **TANK HUNTERS**

Tank hunters are especially skilled at finding and exploiting weaknesses in the armour of enemy vehicles. They add +1 to their armour penetration rolls whenever they hit a vehicle (both at range and in close combat). In addition, they automatically pass Morale checks caused by tank shock.

## **TURBO-BOOSTERS\***

Units mounted on bikes and jetbikes may utilise turbo-boosters to move at extreme speed. When using their turbo-boosters they may move up to 24" in the Movement phase. Controlling their bike at such speeds takes all their concentration and skill, however, so they cannot move through difficult terrain, shoot, launch assaults or execute any other voluntary action in the same turn. In the following enemy Shooting phase, the bike benefits from a cover save of 3+ to represent the difficulty of hitting such fast-moving targets. In that enemy Shooting phase, however, bikers lose the ability of going to ground, and automatically pass Pinning tests. A unit using turbo-boosters must end its move at least 18" away from its starting point to claim this cover save, as it relies on flat-out speed.

## **VULNERABLE TO BLASTS/TEMPLATES**

Some units are especially vulnerable to blast weapons and template weapons. If the unit is a vehicle, then each hit counts as two hits. If it is not a vehicle, each unsaved wound is doubled to two wounds.

# BUILDINGS AND RUINS

The buildings of the Warhammer 40,000 universe range from the small, primitive structures built by tribesmen on feral planets, through to huge futuristic skyscrapers, crystalline spires, hardened adamantium bunkers or glistening biostructures. In addition, many of the structures on a battlefield have been reduced to ruins. Coping with this variety of different structures, or even the rather smaller number of types you are likely to see on the average wargames table, can cause problems. Generally at the most inopportune moment, when the battle is raging at its fiercest, a player will discover his opponent had an entirely different take on how the rules apply to a particular building. To help you deal with these problems, and hopefully confine the bloodshed to the tabletop, we've put together the following guidelines.

## DEFINING BUILDINGS AND RUINS

As with any type of tabletop terrain, it is worthwhile discussing with your opponent what effect each different structure will have before the battle begins. This need not be a time consuming process; in fact it will probably only take a few minutes, and each structure can be as complicated or as straightforward as you and your opponent wish it to be. There is no right or wrong way to choose how your buildings and ruins work – they can even behave differently in different games!

## BUILDINGS

This category includes all those intact buildings in which players cannot physically place their models, because they are solid pieces of terrain. This includes military buildings like bunkers and barracks, but other intact structures as well, such as the hardened control centres at a spaceport, for example. On the battlefield, intact buildings can be used not only as cover to hide behind, but you can imagine your models entering them and using them as a firing position from which to repel the enemy. Buildings use aspects of the transport vehicle rules allowing squads from both sides to occupy and fire from them, or try to destroy them.

### Impassable buildings

Some buildings in your terrain collection may look impossible for models to enter (fortifications with barred doors, solid metal cubes, imprisonment facilities, etc.) or that it makes no earthly sense for models to enter (gas storage silos, white-hot smelting cauldrons, thermonuclear reactors, etc.). Any of these buildings can be deemed impassable terrain.

## RUINS

These structures have taken a hammering from shells, explosions and rampaging war machines. They are normally composed of badly damaged walls sitting amongst piles of broken rubble. Ruins can also have one or more floors partially intact. As they are often lacking large chunks of walls and roof, ruins are the easiest for gaming purposes. Players can place their models inside and move them around to show their position. No abstractions are required – both players will be able to see the models for themselves.



*This Space Marine command post is built to withstand attack – it could be treated as a building.*

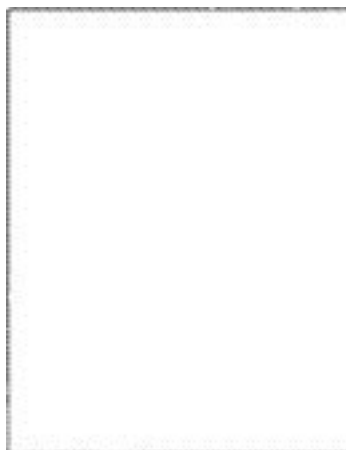

*This Tau power relay is bursting with radioactive hazards – it is best considered impassable terrain.*

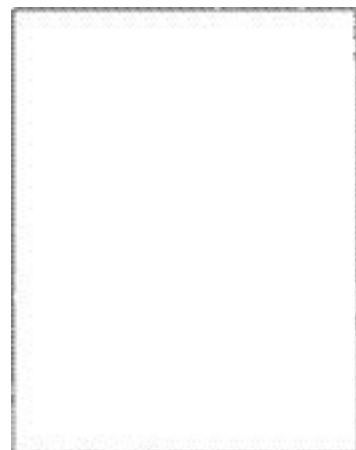

*This battered administratum structure is a perfect example of a ruin.*

## BUILDINGS

The bloody battles of the 41st Millennium often envelop cities, towns, defence lines, research outposts, hab blocks, pumping stations, army barracks, mining colonies, space ports, tribal forts, ancient tombs, sacred shrines and countless other types of building. In the middle of a war zone, such structures are generally deserted, and as such they can be used as defensive positions for troops from either side. Depending on their size, buildings can house anything from a small squad to an entire army.

Not all buildings need be designed with a military purpose in mind – they merely need to be intact structures (preferably with thick walls and good arcs of fire) that troops can use as a defensive position against an oncoming foe.

Which pieces in your terrain collection count as buildings is up to you and your opponent, but they can range from unprepossessing wooden shacks to stone dwellings and ceramite bunkers to ancient alien hab-complexes and battle fortresses.

Buildings of all types use aspects of the transport vehicle rules. The main difference between them and actual vehicles is that they can't move, and units from either side can go inside.

Some bunker or bastion models may be fitted with their own weapons. These weapons cannot be used to shoot unless previously agreed with your opponent, or unless there are special rules for that terrain piece or the mission you intend to play that specifically say otherwise. It is generally a good idea to assume that these weapons were abandoned long ago, and that they no longer work.

### IMPASSABLE BUILDINGS

There are times when a player's collection may include buildings that makes no sense for warriors to enter – huge storage tanks, vast solid monuments and the like. In game terms we refer to these structures as impassable buildings.

#### Impassable buildings and movement

If a building is agreed to be impassable at the start of the game, it follows the normal rules for impassable terrain, and models cannot go inside it for any reason. This is not to say that models will not interact with the building – it will of course block line of sight and provide cover for models sheltering in its lee.

Remember that if it is possible to physically place models on top of an impassable building, jump infantry, jetbikes and skimmers are allowed to end their move there, treating it as dangerous terrain. As usual, a brief discussion with your opponent about the building before the game begins is well worthwhile.

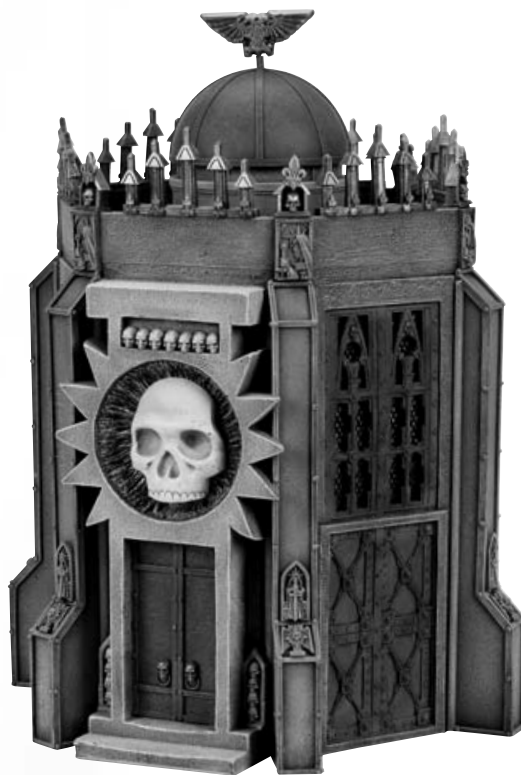

*A shrine of the Adepta Sororitas.*

### **What sort of game?**

*Warhammer 40,000 players like many different things about the game. Some see it as a purely competitive, tactical exercise, some prefer to focus on telling an exciting story as the battle unfolds, while others just love writing their own rules – devising new missions, creating special characters or even changing the main rules of the game! Obviously, players that meet regularly, at someone's house or a club, quickly learn what sorts of games their friends like to play. However, when you are gaming against someone new, it's always worth spending a few minutes before the battle talking about the game.*

*For example, if you have any ruins, you should agree exactly how to use them. One player may prefer to treat them simply as area terrain so that he can concentrate on his grand plan, while another may like the additional story-telling that is created if models cannot move through solid walls or climb up levels without stairs or ladders. Yet another player may have written a house rule where an elevator is activated if you also have models next to the power generator on the other side of the table! No single approach is right or wrong, as long as both players have agreed before the game.*

## OCCUPYING BUILDINGS

Models can enter or exit a building through a doorway or other opening that the players have agreed to treat as an access point. Players should decide what the access points are before deployment, in order to avoid any possible confusion on this matter. This aside, moving into or out of a building works the same as embarking or disembarking from a vehicle (including emergency disembarkations).

All of the normal rules apply, so only one infantry unit (plus any independent characters that joined them) may occupy a building at one time. The 'transport' capacity of a small bunker might be ten models, while a large bastion could hold any number of models from a single unit. Again, this can vary according to what you and your opponent agree on before the game begins. Often, a Codex specifies that a certain infantry unit made of rather large models may use transports, but will count as more than a single model (Space Marine Terminators, for example, count as two models each). These rules should also be used whenever such units enter a building (so, to continue our former example, up to five Terminators could occupy a bunker that the players have agreed to have a capacity of ten models).

Models entering a building are removed from the table – you can either note down where they are on a piece of paper or use another suitable reminder. Units of jump infantry, jetbikes and skimmers cannot land on a building that is occupied by enemy units.

You'll find that some structures won't have obvious doors or stairs allowing access, but you wish to use them as buildings, rather than impassable terrain. For example, we've got some Orky buildings that include little watchtowers – unfortunately they lack any visible method for actually getting up to the watchtower! In cases like this the players can simply agree to assume that there are internal doors or ladders which allow access to the building.

## FIRING FROM BUILDINGS

Just like some transport vehicles, buildings have fire points that allow units inside to fire out. These could be the fire slits on bunkers and bastions or the windows on other buildings. Players should agree beforehand where these fire points are. Unless the players agree otherwise, up to two models may shoot through each fire point of a building. Note that all of the models in a unit firing from a building can only target a single enemy unit, as normal.

## ATTACKING BUILDINGS

The best way to kill enemy troops in a fortified position is usually just to destroy the fortified position. Units may shoot at or assault an occupied building just as if it was a vehicle. Units inside a building may not be attacked directly, but will be affected in the same

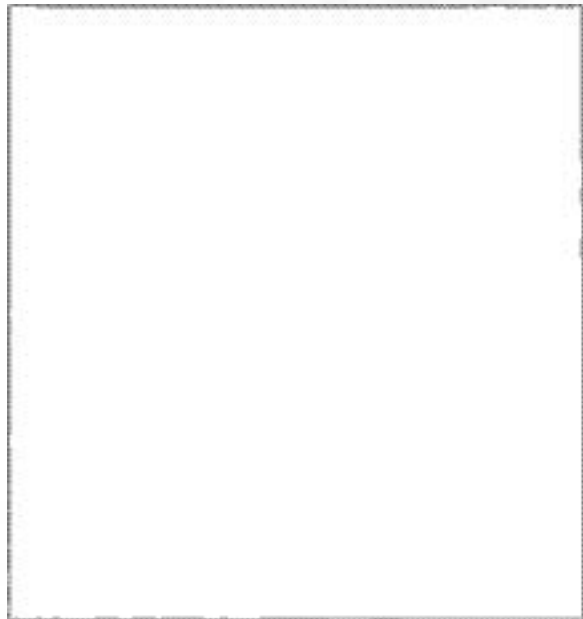

*All Space Marines in the squad have moved to within 2" of the building access point, so that the unit can 'embark' into it.*

manner as units inside a transport vehicle should the building be damaged, and so may suffer damage and/or be forced to 'disembark'.

Bunkers and bastions have an Armour Value of 14 all around. The Armour Values of other buildings may vary between 9 and 13 (see the chart below for some examples). The players must agree at the start of the game on the Armour Value of all buildings in use.

When shooting at a building, roll to hit and for armour penetration normally (in close combat they are hit automatically, just like stationary vehicles). Buildings treat stunned, immobilised and weapon destroyed results as shaken results instead (weapon destroyed may work as normal if you have agreed to use the weapons mounted on the building, of course). Wrecked buildings are treated in the same way as a wrecked vehicle, and therefore become difficult and dangerous terrain. If one is available, players may like to put down a ruin in its place. Buildings that explode can be replaced with an area of rubble or a crater.

## BUILDINGS ARMOUR CHART

Building	Armour Value
Bastion or bunker	14
Stone-walled palace	13
Concrete city building	12
Brick house	11
Log cabin	10
Corrugated iron or wooden shed	9

## Template weapons

Template weapons such as flamers are designed to attack enemies hidden behind defensive terrain, and can attack models even if they are inside a building.

To represent this, if one or more of the fire points on a building fall under a template, the unit occupying the building suffers D6 hits from the template weapon. The building itself also suffers one hit, as normal.



The Ork is hitting the unit occupying the building by firing his burna at the fire point.

## PARAPETS AND BATTLEMENTS

Many buildings are constructed so warriors can be positioned on the roof and fire from behind fortified parapets or battlements. This allows extra models from the unit to fire, but leaves the building more vulnerable to attack. If any models from the unit are placed on a parapet, they can fire in addition to those using firing points. They still count as being in the building though, so cannot be shot or assaulted directly. However, if a Damage roll is made against the building while some occupiers are on the roof, add +1 to the result.

### **Use your imagination!**

Some players may want to use a very large building, such as a fortress, which could include towers, battlements, bunkers and so on, each with different capacities and Armour Values. You may simply want to deploy a unit inside a building and another on the roof. You may even want to come up with rules for jump packers assaulting enemies on parapets. Inventing extra rules like this is great fun, and will make for a very different game. Players will have to agree before the game how will models move between two adjoining elements, and other details. You may even want different elements of a fortress to be treated as several types of structure – perhaps one section is ruined, another impassable, whilst the rest is treated as one or more buildings – see opposite for an example. As with most other things that we have discussed in this section, the only limits are the buildings you own and your imagination.

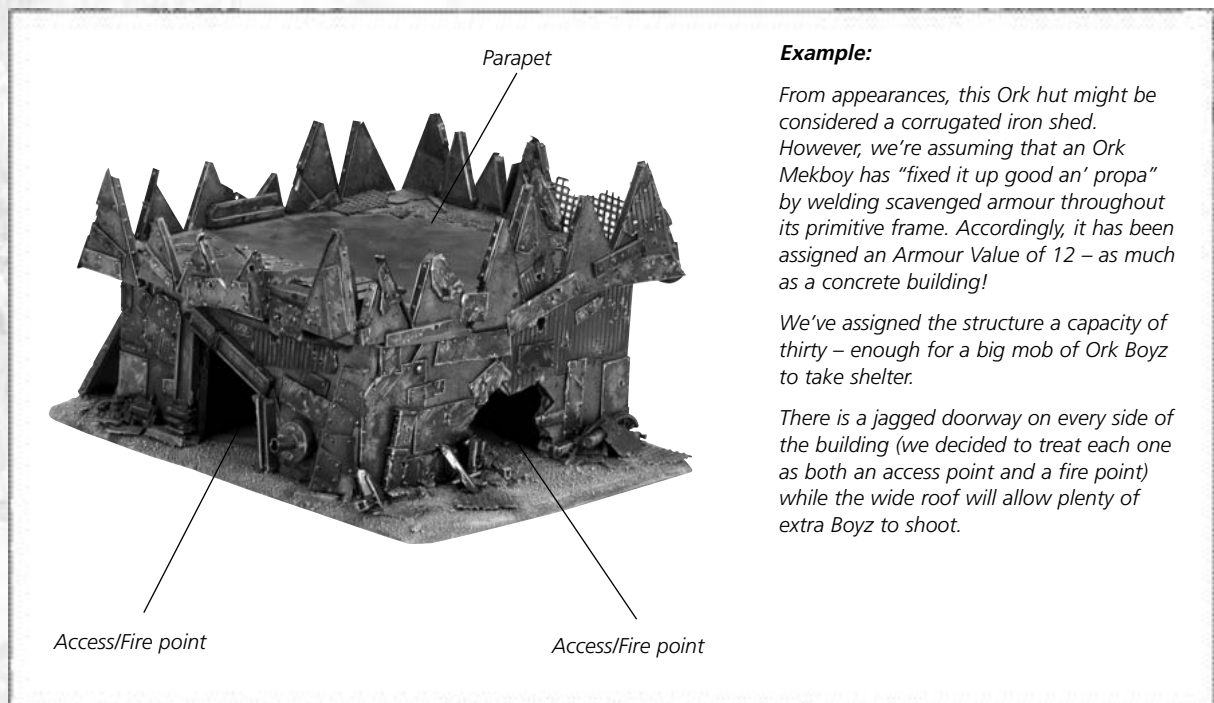

### **Example:**

From appearances, this Ork hut might be considered a corrugated iron shed. However, we're assuming that an Ork Mekboy has "fixed it up good an' propa" by welding scavenged armour throughout its primitive frame. Accordingly, it has been assigned an Armour Value of 12 – as much as a concrete building!

We've assigned the structure a capacity of thirty – enough for a big mob of Ork Boyz to take shelter.

There is a jagged doorway on every side of the building (we decided to treat each one as both an access point and a fire point) while the wide roof will allow plenty of extra Boyz to shoot.

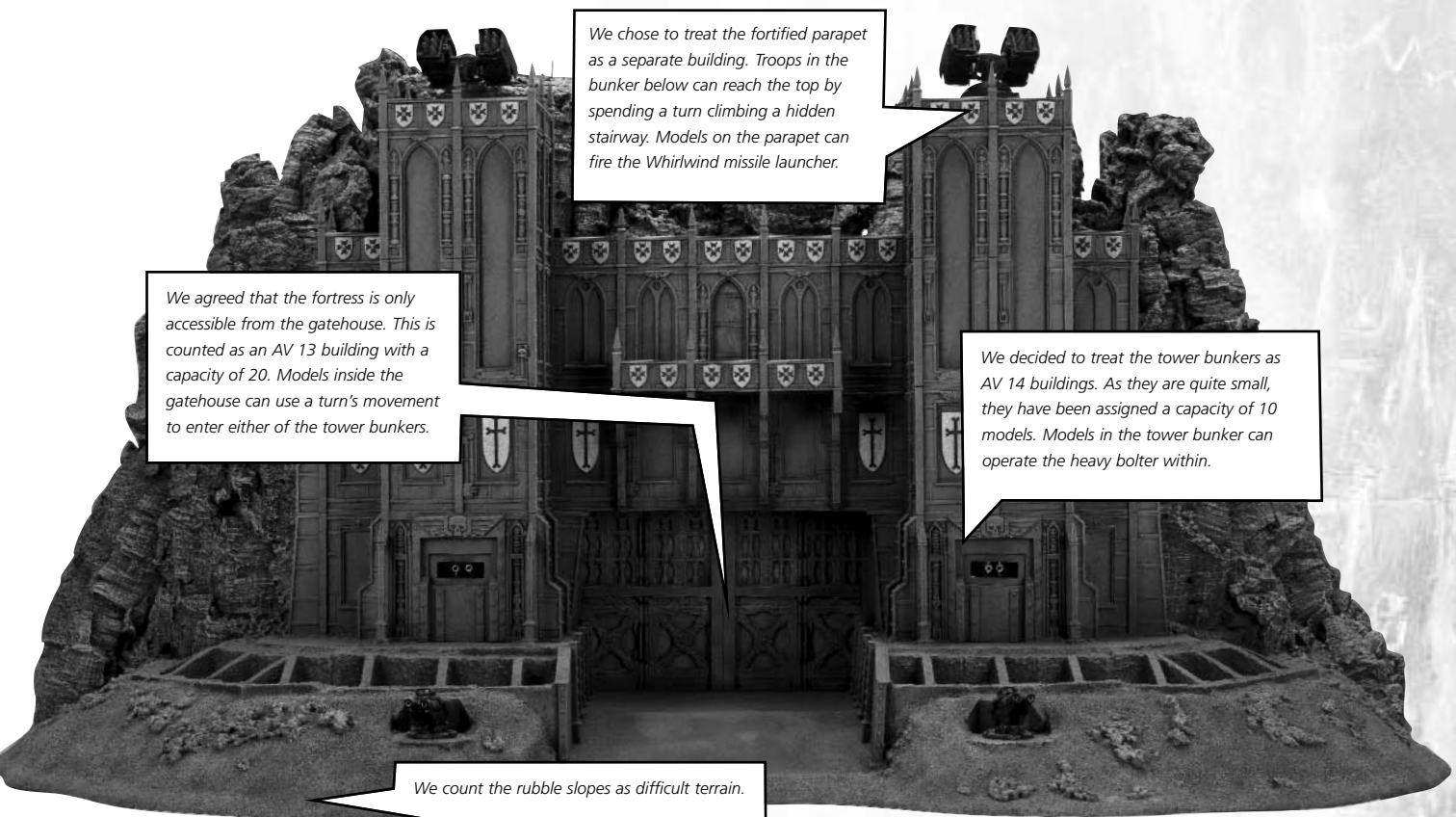
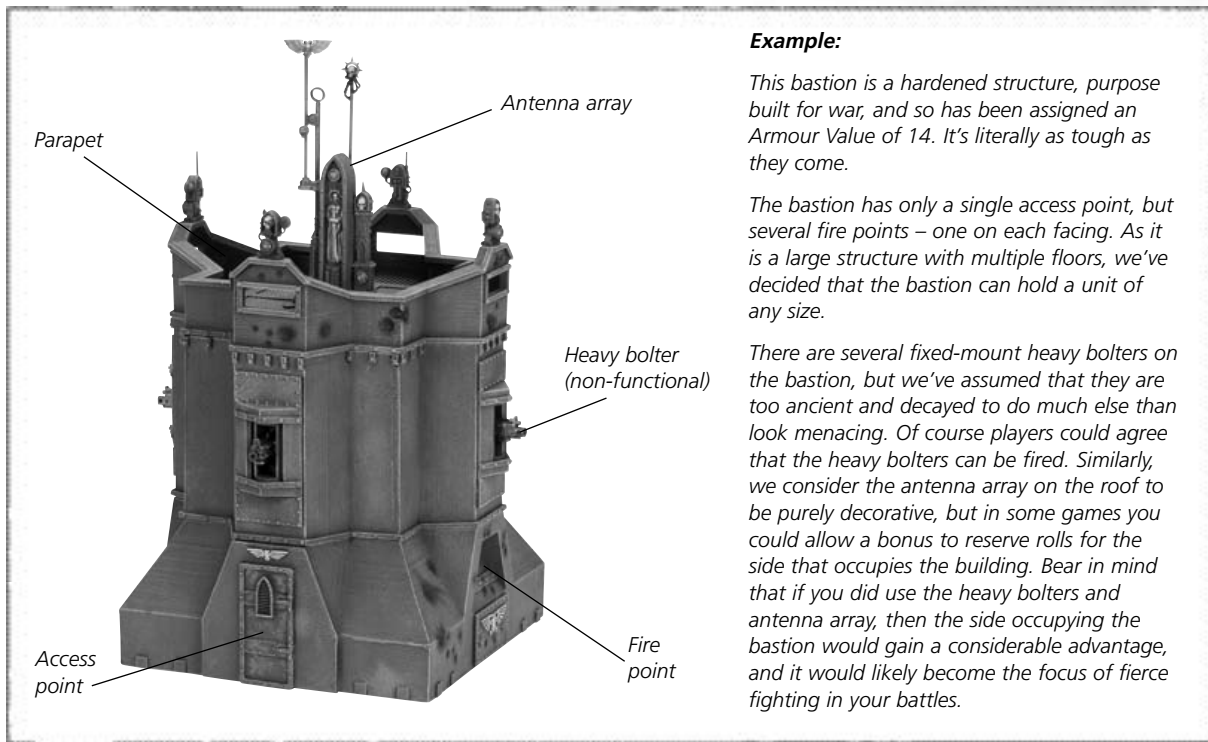

This glorious building is an extreme example of the fun you can have with the rules for buildings. While such a structure is complicated and likely to dominate any game it appears in, it'll certainly give you a battle to remember!

## RUINS

This section concentrates on ruins – the ones that players can actually place their models inside. The extra height and multiple levels of ruins require some extra clarifications to explain how certain rules work. For example, it is useful to explain how unit coherency, and blast markers and templates work in this environment.

These rules are based on the height and area of the plastic Warhammer 40,000 city ruins. They will work just as well with ruins of your own creation, so long as their dimensions are roughly similar.

### RUINS: THE BASICS

All ruins are area terrain (providing a 4+ cover save) and difficult terrain. Players may also agree at the beginning of the game to treat some ruins as dangerous terrain as well, representing unstable structures on the verge of collapsing or that are still on fire. Of course, the nature of ruins means that the boundaries of the area terrain can be somewhat indistinct. The best way to counter this is to ensure that both players are clear on the limits of each ruin before the game begins.

#### Ruins with bases

A ruin may be mounted on a base, decorated with rubble, collapsed walls and other debris, in which case it is best to treat the base exactly the same as the upper floors – as area terrain (providing a 4+ cover save) and difficult terrain.



*An example of a two-storey ruin mounted on a base.*

#### Ruins without bases

If the ruin has not been mounted on a base, then the ground floor is not counted as either difficult terrain or area terrain. Of course, units will still have to take difficult terrain tests if they move through the walls or if they climb to the upper floors (see opposite).

### COPING WITH DIFFERENT HEIGHTS

With units in ruins you will often need to measure weapon ranges between models on different levels and at different heights. Measure the distance from base to base, holding your tape measure at an angle as necessary. Sometimes a wall of rubble or an exposed stanchion will get in the way and you'll find it difficult, or impossible, to accurately measure the distance. Should this happen, it's more than acceptable to estimate based on what you can measure.

### UNIT COHERENCY

In the course of movement, it is possible that several models from the same unit may end up spread across two or more levels of a ruin. When this happens, the models in the unit maintain unit coherency as long as any part of the body of a model on a lower level is within 2" of the base of a model that is higher up. This means that you measure up 2" from the head of a model on one level to the base of the model on the next level up, and so on. Players should be generous when measuring for very short models, like swarms, which otherwise may be unable to spread over several levels of a ruin (give them a break – they're only little!).



*The Space Marines in this squad are in unit coherency.*

## MOVING WITHIN RUINS

Only certain troops are capable of clambering to the upper levels of ruins. Accordingly, only infantry, jump infantry, jetbikes, monstrous creatures and walkers may move on the upper levels of a ruin – and only if the model can physically be placed there. Other units may only move on the ground level of the ruin.

### Infantry, monstrous creatures and walkers

Even though different building models can vary in this respect, we assume that every level of a ruin is 3" tall. A model moving on foot in a ruin therefore needs 3" of its movement to go up or down a level. As ruins are difficult terrain, this means that if a 1 or 2 is rolled, a model may not make any vertical movement (but may still move horizontally on its level). If a 3 is rolled, the model can either move up to 3" horizontally or simply go up or down a level without any horizontal movement. If a 4 or 5 is rolled, a model can either move horizontally up to the maximum rolled or go up/down a level as well as moving its remaining 1" or 2" horizontally. On a result of 6, the model will be able to go up/down two levels if it does not move horizontally at all, or move one level up/down and horizontally for the remaining 3".

### Jump infantry and jetbikes

Remember that jetbikes, and jump infantry that are using their packs, are not hindered by difficult terrain, and may move over any terrain as part of their move without penalty.

However, if these models start or end their move in difficult terrain (such as a ruin!), they must take a dangerous terrain test. All surviving models are then simply placed within 12" of their starting point, including on a different level of a ruin (as shown in the diagram on the right).

### Walls, doors, ladders and lateral thinking

Should troops be able to move through walls if there is no door? That's really down to what you and your opponent decide. It's perfectly acceptable to assume the combatants on both sides have brought plenty of cutting tools, acidic disintegrators or naked ferocity to muscle their way through any wall so foolish as to block their path. Indeed, the normal rules for moving through difficult terrain allow you to do just this. Equally you could decide that models can only pass from one side of a wall to the other if they walk around, or if there is a door, window, grate or similar handy opening.

The same is true of ascending and descending levels within a ruin. It's just as valid to assume that the combatants should be able to climb the few feet from one floor to the other as it is to disallow models from climbing higher in a ruin that has no ladders. Just remember that the more involved your rules for ruins are, the longer the game will take.



*The Space Marine's difficult terrain roll of 5 allows him to move 2" horizontally and one level up (3").*

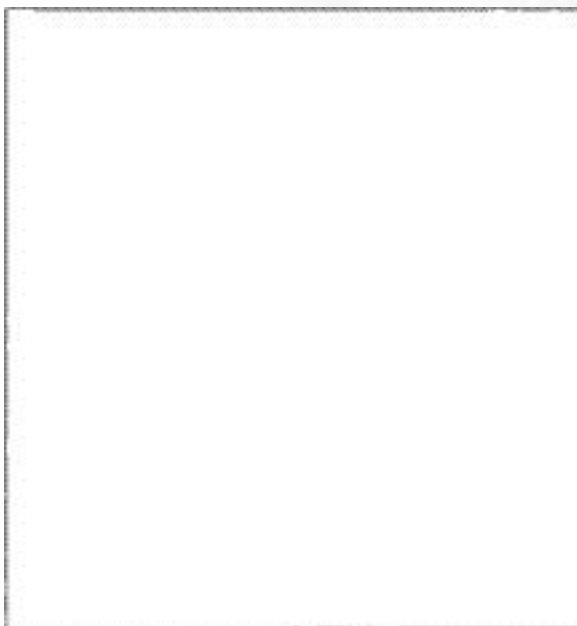

*The jetbike has passed its dangerous terrain test and can therefore move up to 12" through the ruin.*

---

**"A fortress is a living thing: the commander its brain, the walls its bones, the sensors its eyes and ears, the troops its blood, their weapons its fists. This tells us two things: If one organ fails, the whole dies. And if the whole dies, no single organ can survive alone."**

---

Mordin Barr

## TEMPLATE AND BLAST WEAPONS

Multi-level ruins require certain conventions and clarifications to ensure that template and blast weapons behave in a consistent fashion, and to keep the game moving.

When firing template or blast weapons at models in a ruin, it can be tricky to physically place the marker or template over the models in question. The best way to gauge which models are actually under the template is to simply hold the template above the entire ruin, and look down through it. This is illustrated below.

The method for placing templates and markers over ruins requires a degree of trust between players, especially when intervening floors obscure your view of the affected models.

Remember that once you have used the template or blast marker to work out how many models are hit, casualties can be removed from anywhere in the squad, including models completely out of the firer's sight.



*It is easiest to hold blast markers and templates above the ruin and look down.*

---

**“There can be no bystanders in the battle for survival. Anyone who will not fight by your side is an enemy you must crush.”**

**Scriptorus Munificentus**

---

## Blast weapons

When firing a weapon with a blast marker into a ruin, declare which floor you are aiming at, and continue as normal. If a blast weapon scatters, it can still only hit models on the level declared as the target.

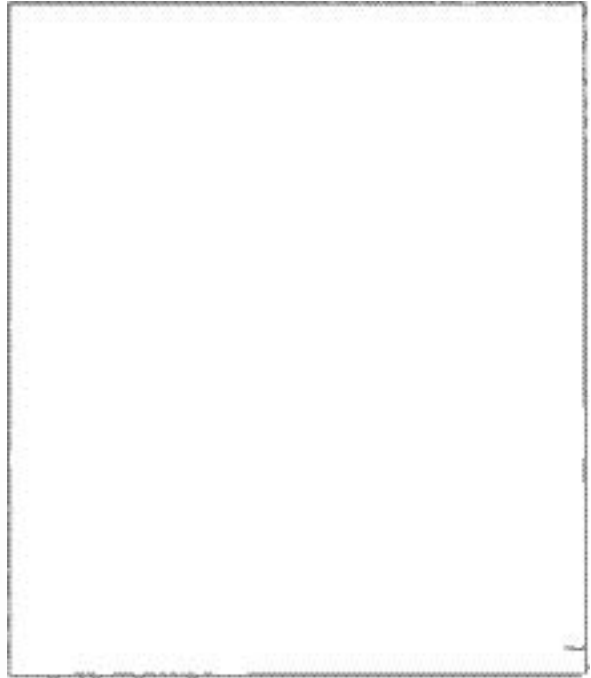

*The Space Marine player has declared that he is targeting the Genestealers on the ground level, and so those on the higher levels are unaffected, even though they are beneath the marker.*



*The Tau Empire player declares that his Hammerhead tank is targeting the Genestealers on the first level. The shot scatters, and although there are still models under the marker, none are on the level declared as the target, so no hits are scored.*

### Barrage weapons

Barrage weapons work by lobbing munitions high into the air, bringing death to the enemy from above. The advantage of these indirect fire weapons is that they can be used to engage targets beyond the limited lines of sight. The disadvantage is that they explode the moment they strike a structure, meaning warriors can shelter deep within the ruin.

Barrage weapons always strike the highest level that is under the hole in the centre of the marker. Only models on this level and under the template are actually hit.

### Template weapons

When targeting a unit in a ruin, template weapons (such as a flamer) may only affect models under the template on a single level. This can be on the same level as the firer, or one level higher or lower. The firer must declare which level is being targeted before placing the template.

A skimmer, jump infantry or jetbike model that fires a template weapon may target models on any single level of the ruin.

## RUINS AND ASSAULTS

Once an assault begins, both friendly and enemy models can end up scattered all over the ruin. For the sake of simplicity, the same principle described for unit coherency is used to determine which models are engaged in an assault. That is to say, distances between models on different levels are measured between the heads of the models on the lower level to the bases of the models on the upper levels (see page 82).

In some cases the ruin might genuinely be unstable or uneven, or the space could be very limited on a particular level, making it impossible to move assaulting models into base-to-base contact with the unit they wish to assault. When this happens, it is perfectly acceptable to place models as close to their foe as is safely possible, including the level below or above, providing that you place the assaulting models as close as possible to their opponents and you make clear to your opponent which of your models are in base-to-base contact with his models. We find that directly below or above works well, representing them charging up or down a flight of stairs.

---

**“There will be no retreat  
from Hades Hive.  
We will fight to the end.”**

**Commissar Yarrick**

---

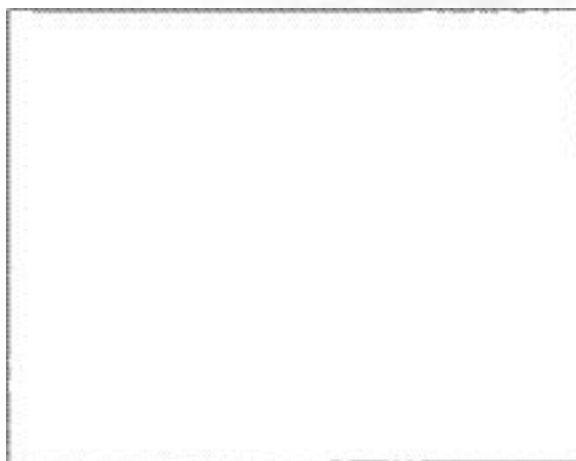

*As the hole in the marker hits the upper level first, only one model is hit by the barrage weapon.*

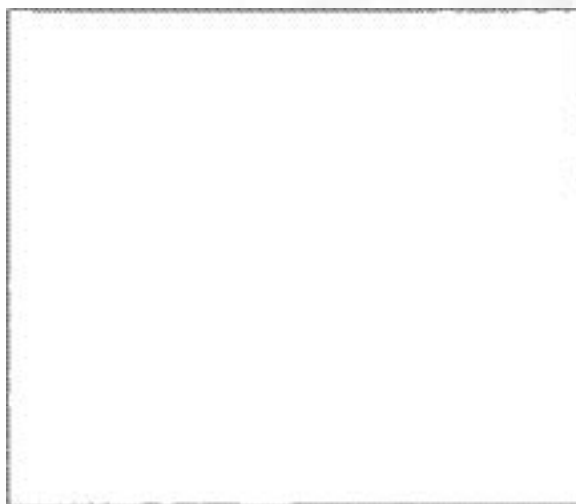

*The middle level is declared as the target of the flamer and therefore only two Genestealers are hit. Note that the top level is not a valid target as it is too high up.*



*All of the models in the picture are engaged and can fight except for models A and B, which are not within 2" of a member of their unit that is in base contact with the enemy.*

# ORGANISING A BATTLE

Now that you've learned the rules for moving, shooting and fighting with your army, we'll look at how to organise a game of Warhammer 40,000, including how to choose your forces, how to set up the battlefield and how to select a mission to play.

## ORGANISING A BATTLE

- 1 **Agree points limit & choose forces**
- 2 **Prepare the Battlefield**
- 3 **Select a Mission**
- 4 **Deploy Forces**
- 5 **Start the game!**

## AGREE POINTS LIMIT & CHOOSE FORCES

A game of Warhammer 40,000 can use as many models as you can collect. The army lists included in the Warhammer 40,000 Codex books specify the precise characteristics and abilities of each troop type, detail the maximum and minimum size of each unit and provide a points value for each model. The better a combatant is, the more points it will cost. Normally a soldier will have a basic cost, which is then increased if you upgrade his equipment or abilities.

The most popular approach to playing a game of Warhammer 40,000 involves both you and your opponent selecting forces to a previously agreed points limit. A limit of 1,500 or 2,000 points per side produces a well-balanced game that can be concluded in a few hours. A 500 points game is still very entertaining, feeling like a clash of patrols, and normally lasts less than an hour. Larger games take proportionally longer, and you might expect a 3,000 points game or more to take the entire day – perfect for a rainy Sunday!

As you build up your armies and become more comfortable with the rules, you will no doubt crave opportunities to get your entire figure collection onto the battlefield and play with bigger points values. Don't be in a mad rush to play huge points-limit games. It is easier to start small and gain familiarity with the rules rather than trying to master everything at once. You will inevitably forget things in your first few games, so it will help to play a number of small, quick games to learn the ropes before moving up to a larger battle.

The first thing players need to do when arranging a game is to decide what points limit they are going to use. For example, they may agree to play a 1,000 points game, in which case the total value of all models in each player force must come to 1,000 points or less (it will often be a few points short, but it still counts as a 1,000 points game).

## FORCE ORGANISATION

Once they have agreed a points limit, the players will pick their forces. The best way to do this is to use the full army lists in the relevant Codex book for each army, but players just starting out can use any models that they have in their collection. As detailed in each army's Codex, all the forces you can use are categorised broadly by categories that tell you something about the role they play in the army. These roles are normally: HQ, Troops, Elites, Fast Attack and Heavy Support. Occasionally, a Codex might introduce new categories or give them alternative names, which better reflect their role in the army in question, but such exceptions will be clearly explained in the Codex's army list section.

### HQ

A Headquarters unit might be a single heroic commander or fearsome monster. These models are amongst the most powerful in the game, as leaders will generally have access to more special equipment than everyone else. They are not invincible, but can provide a powerful spearhead for an attacking army, and a strong core for a defensive one. Every army contains at least one Headquarters unit to command it.

### Troops

These represent the most commonly available soldiers in an army. This does not mean they are poor fighters though; the category includes such troops as Space Marines and Ork Boyz, both formidable adversaries. These are the warriors that make up the bulk of an army, and every army will have at least two such units. These units' main tactical role is that of consolidating the gains of the army and defending the objectives that have been taken by the army's more specialised units.

### Elites

Elite units are normally powerful but expensive. They are the best soldiers an army has to offer, but there are never enough of them. In some cases they will be specialists, while at other times they will be more experienced versions of the regular soldiers.

## Fast Attack

Fast Attack units are generally (surprise, surprise!) faster than their comrades and are masters at manoeuvre. Often they are responsible for reconnaissance and scouting, while at other times they are assault troops relying on speed to strike at the heart of the enemy.

## Heavy Support

Heavy Support units are literally the big guns of the army. In this section you will find the heaviest items of equipment and the toughest creatures. However, these units are also very expensive in points, so an over-reliance on them might leave you badly outnumbered.

## FORCE ORGANISATION CHART

The minimum and maximum numbers of each of these types of unit for each army are detailed on the force organisation chart of each army Codex book. Shown on this page is an example of one such chart, which is the one used by most armies for standard missions (i.e. the three missions presented later in this section).

One box on the chart allows you to make one selection from that part of your army list. Dark boxes are compulsory selections. As you can see, normally you will have to take at least one HQ selection and two Troops selections. These compulsory choices ensure that whatever else you select, your force will have a core within it that is representative of that army. This is rarely a disadvantage and many players often use the maximum number of Troops selections.

Sometimes a single choice on the force organisation chart will allow you to select more than one unit. This will always be explained in the appropriate Codex, so be sure to read it carefully.

## Dedicated transports

Dedicated transport vehicles sit outside the Force Organisation structure, as they are attached to the unit they are bought for. When this distinction is called for (for example in some missions or deployment types), dedicated transport vehicles count as being from the same force organisation category as the unit they were bought for. For example, a Rhino bought for a Space Marine Tactical Squad (Troops) counts as a unit of Troops, but if it was bought for a unit of Veterans (Elites) it counts as Elites.

## Other exceptions

Quite a few Codex books include units that, much like dedicated transports, are not part of the army's force organisation chart. This may be because they are too puny, specialised support units, or simply not part of the main fighting forces of that race. Often labelled with terms such as 'supernumerary' or 'insignificant', these units normally do not count towards the number of choices the player can make from the force organisation chart and have rules that will clearly tell the player how many can be included in his force.

## EXAMPLE OF A FORCE ORGANISATION CHART

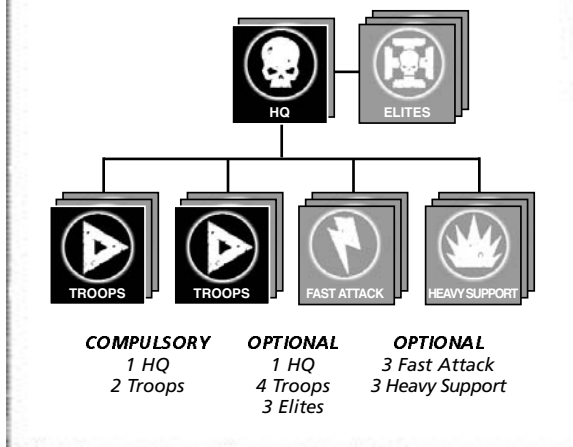

## Multiple detachment games

As your collection of miniatures grows, the urge to use them all at once will become hard to resist. Above a total of 2,500 points, the force organisation chart deliberately becomes a very limiting factor. The chart allows you to build the minimum sized force that can reasonably be expected to complete a mission. On a larger scale, an army will consist of many such detachments, each performing separate missions. If you want to play an especially large game then, as well as agreeing a points limit, you should also agree a maximum number of detachments. Each detachment will be a separate army, using its own force organisation chart.



## Non-standard missions

Players may of course make up their own missions, varying the way units are deployed, the victory conditions, the terrain, or even adding their own mission special rules to represent artillery barrages, volcanic eruptions, alien teleportation devices or anything else you can think of. They may also decide to vary the force organisation chart, to represent different forces, more suitable to their missions. They may want to change the compulsory/optional units, or increase, decrease or remove altogether one kind of unit (no Heavy Support and two compulsory Fast Attack units, representing a rapid insertion force, for example). More examples of non-standard missions can be found in other Warhammer 40,000 supplements.

## PREPARE THE BATTLEFIELD

### THE GAMING SURFACE

Standard missions are designed to be played on a 6'x4' gaming surface, with each player sitting behind one of the long table edges ('his own' table edge, see diagram below). The concept of 'own' table edge is important, because when units fall back, they will always fall back towards 'their own table edge'. We assume this is in the direction of their base of operations. The remaining two edges of the gaming surface are referred to as the two 'short table edges', which do not belong to any player, as shown in the diagram below.

If you are playing a game with a very large or small points limit, you may want to consider larger or smaller gaming surfaces. Whatever the size and shape of your table, it is important to establish the different table edges as described.

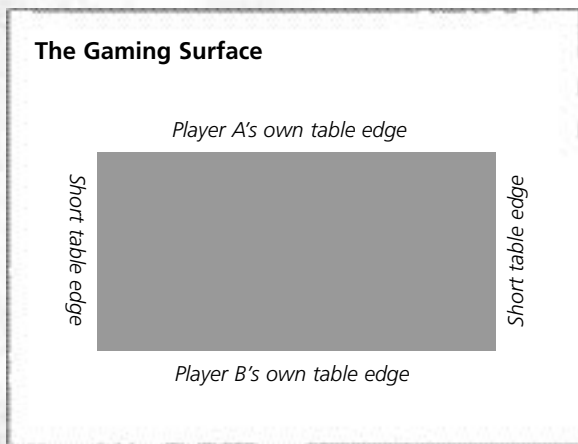

### SETTING UP TERRAIN

Setting up a well-modelled, interesting battlefield will enhance the enjoyment that you get from playing a game of Warhammer 40,000. Many players will collect several armies before considering the possibility of investing in some good terrain. This is a shame, as a new set-up for your games can breathe fresh life into the most heavily played armies and missions. Adapting your tactics from fighting in rolling woodland to capturing buildings, ruins and other heavily defended positions is both challenging and fun.

It is best if the players place the terrain together, ensuring that the set-up is acceptable to them both. Alternatively, you may ask a third person to set up the terrain in a fair manner. A third common way of setting up the terrain is for the player hosting the game (or arriving first at the club) to set the terrain up, and for the other player to automatically win the roll to choose who deploys first (see missions). In tournament play, terrain will normally be pre-set by the organisers.

### HOW MUCH TERRAIN?

As a general rule in Warhammer 40,000, the more terrain, the better the gaming experience. If you use too little terrain, games will be short and not very satisfactory, with too much advantage going to the player who gets to shoot first. For a balanced game, where close combat troops have a chance to get into contact with the enemy without being completely blown away in a couple of turns, we expect that about a quarter of the total playing surface should have terrain on it. The assumption here is that if terrain pieces are roughly 12" by 12", then six or seven pieces are needed to fulfil the 25% recommendation on a standard 6'x4' table (of course these dimensions are approximate and terrain features like woods should not be square, as irregular features look much better!).

In your terrain collection there should be a good mixture of types. An equal division between terrain which interferes with line of sight and provides cover (such as woods or ruins), terrain which provides cover, but does not block line of sight (such as barricades, craters, scrubland and low rubble) and terrain which blocks line of sight completely (such as hills, rocky outcrops, buildings, etc.) makes for good tactical play. It is best to build your terrain collection with this in mind, otherwise the game balance could be seriously affected. Terrain that completely blocks line of sight is particularly important. Too much of it and your ranged firepower will be seriously impaired favouring assault troops; too little and the game will turn into a shooting match, with very little movement or tactical choices.

### DEFINE THE TERRAIN

Before continuing, you should agree with your opponent how to define each piece of terrain you are using (see pages 13 and 77 for more details). This doesn't take more than a few minutes, but it is important to do before the battle starts – otherwise it has a tendency to cause confusion and arguments in the middle of the game. Of course if you are playing with your usual adversary on the same terrain that you always do, this will be as simple as saying "Just like last time, okay?" However with a less familiar opponent, or if you are playing over some new terrain, remember to clarify the following:

- Which terrain pieces are **area terrain, difficult terrain** or **dangerous terrain** (or a combination)?
- Which terrain pieces are **impassable terrain**?
- Which terrain pieces are **ruins**?
- What **cover saves** do different terrain pieces confer?
- Which buildings are **impassable**?
- What are the **Armour Values, fire points, access points** and **capacity** for any buildings?

# EXAMPLE BATTLEFIELDS

## Wilderness outpost

The battlefield on the right has been based around the wargaming terrain staples – woods and hills – with the addition of some other elements to provide the Warhammer 40,000 flavour. The players have taken turns to place the ‘wilderness’ elements of the terrain, and because neither knows yet where his army will be deploying, they have both taken care to ensure there is an even spread over the table. This means that wherever their forces end up, there will be some cover nearby.

The use of a bastion makes it clear that the battle is set in the 41st Millennium. Because whichever side occupies this building will have a useful advantage, the players have agreed to place it in the centre of the table – the armies will have to fight to gain its protection. The road will allow vehicles to cross the board quickly, in order to transport passengers or contest objectives themselves – plus it really adds to the look of the battlefield.

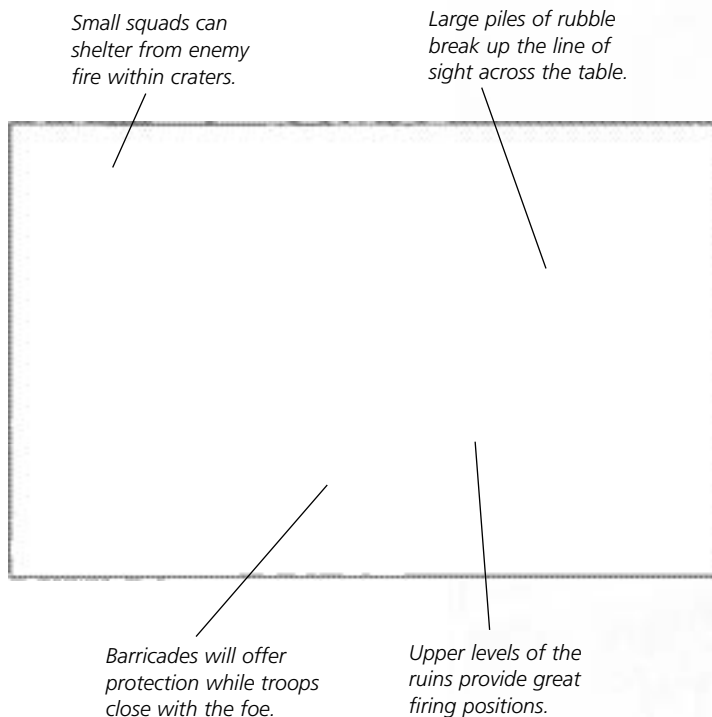
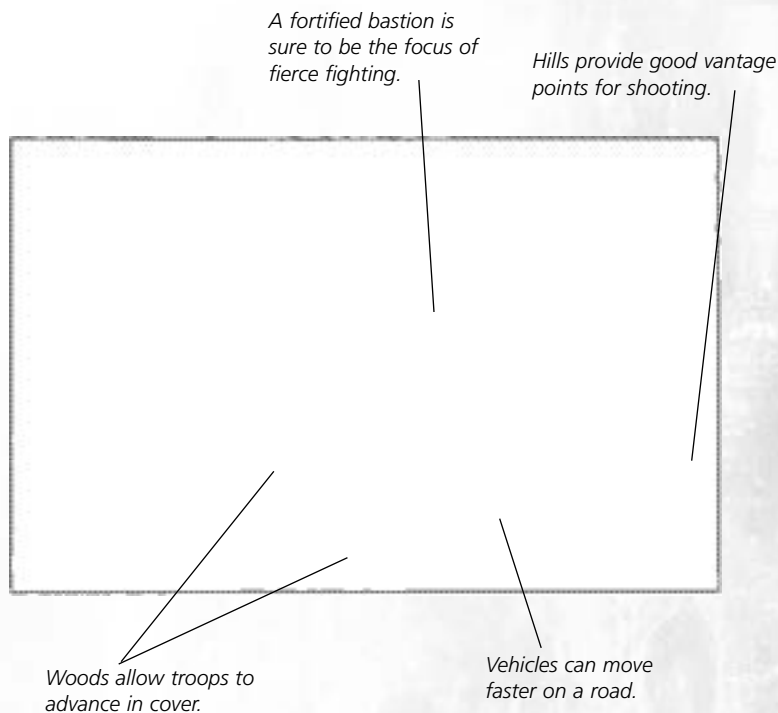

## War-torn settlement

In the example on the left, one player has set up all the scenery, arranging it to represent a small settlement, blasted and ruined by years of war. His opponent will then get to decide whether to deploy first or second, thereby choosing the best angle of attack.

The various ruins will block models' views across the table, forcing units to manoeuvre and advance on the enemy. Of course models in the upper levels of the ruins will have a great vantage point, so these structures will be tactically important – especially if objectives are placed within them. The piles of rubble and barricades provide cover for warriors, as do the craters. Squads that run from one piece of terrain to the next will be able to stay protected from enemy fire.

---

**Serve the Emperor today,  
tomorrow you may be dead.**

---

## SELECT A MISSION

Missions define how to work out which side has won, dictating the tactics that the players will have to employ during the battle. The three standard missions in this section are the most common way Warhammer 40,000 battles are played. They are relatively simple, and do not require an army that is designed specifically towards a single style of play. You can either agree with your opponent which mission to play, or roll D6 and consult the chart below:

### STANDARD MISSIONS CHART

D6	Mission
1-2	Seize Ground
3-4	Capture and Control
5-6	Annihilation

## ENDING THE GAME

Standard missions last a random number of game turns – between five and seven. At the end of game turn 5, a player must roll a dice. On a 1-2 the game ends immediately, on a 3+ game turn 6 is played. If this is the case, a player will roll another dice at the end of game turn 6, and this time on a 4+ the game continues and game turn 7 is played. At the end of game turn 7, the game ends automatically.

In standard missions, as soon as the game ends and before working out victory conditions, all units that are falling back are removed and count as destroyed.

## WIPEOUT!

Regardless of the victory conditions, if at the end of any standard mission your enemy has no units left on the table, you win the game!

## SCORING UNITS

During a military campaign the most powerful and specialised units assault the objectives and take them. They then forge ahead to the next objective, engaging the enemy with lightning-fast assaults and irresistible armoured thrusts. It is left to the grunts, the squads making up the bulk of any fighting force, to dig in and consolidate any territorial gains, defending the objectives from any enemy counter-attack.

The concept of scoring units is central to the first two standard missions, which are won or lost by controlling more objectives than the enemy (see those mission's victory conditions), and only scoring units can do that.

An army's scoring units are all the units that come from its **Troops** allowance. The presence of other units may deny an objective to the enemy, but only Troops can control it. There are a few exceptions, however, when a unit of Troops does not count as scoring:

- If it is a vehicle.
- If it has the Swarm special rule.
- If it has a special rule specifying it never counts as a scoring unit.

Unit of Troops embarked in a transport can control objectives (measure the distance to their vehicle's hull).

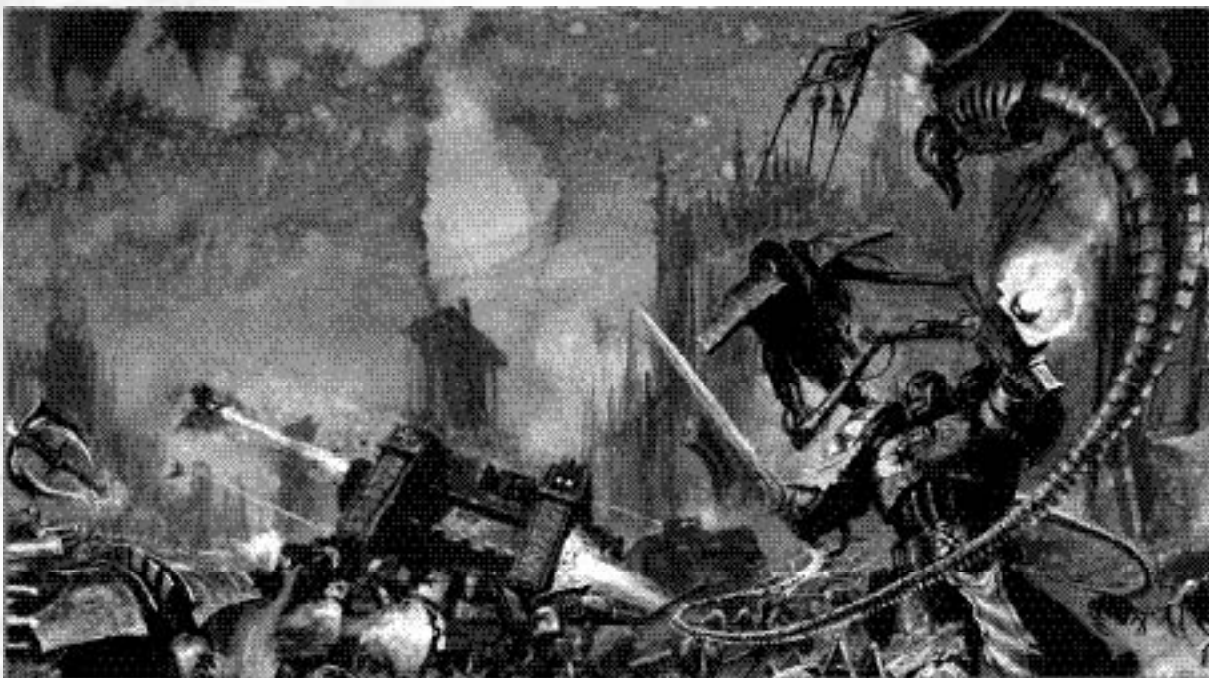

## SEIZE GROUND

The battlefield is strewn with discarded equipment, wounded comrades, supplies and other detritus of war that, for various reasons, you wish to recover. You must fight off the enemy while scouring the field to secure as many of these vital objectives as you can.

### Victory Conditions

Before deciding deployment zones (see next section – Deploy Forces), the players must determine the position of D3+2 objectives. The winner of a roll-off chooses a point on the table to be an objective (by placing a counter on it, choosing a detail of a terrain feature, or any other method that is equally clear). Then the opponent does the same, and the players alternate choosing a point on the table until the position of all the objectives has been determined.

These objectives may not be in impassable terrain, nor within 12" of a table edge or another objective.

After positioning the objectives, deployment of the forces begins, as described in the type of deployment being used.

At the end of the game you control an objective if there is at least one of your scoring units, and no enemy unit (any unit, whether scoring or not), within 3" of it. As different objectives vary in shape and size, it is important to agree at the beginning of the game exactly where this distance will be measured from.

The player controlling the most objectives wins. If the players control the same number of objectives, the game is a tactical draw.

## CAPTURE AND CONTROL

Both sides are attempting to capture the enemy base of operations or another similarly vital objective, whilst defending their own.

### Victory Conditions

After deciding deployment zones, but before deploying any unit (see next section – Deploy Forces), starting with the player that will deploy first, each player chooses a point in his own deployment zone to be an objective (by placing a counter on it, choosing a detail of a terrain feature, or any other method that is equally clear). These objectives may not be in impassable terrain or within 24" of the other objective.

After positioning the objectives, deployment of the forces begins, as described in the type of deployment being used.

At the end of the game you control an objective if there is at least one of your scoring units, and no enemy unit (any unit, whether scoring or not), within 3" of it. As different objectives vary in shape and size, it is important to agree at the beginning of the game exactly where this distance will be measured from.

The player controlling the most objectives wins. If the players control the same number of objectives, the game is a tactical draw.

---

**“Strike fast and suddenly. Attack without warning. Secure victory before the foe is aware of the danger.**

**Remember always, a war is easily won if your enemy does not know he is fighting.”**

Maxims of Lord General Solar Macharius

---

## DEPLOY FORCES

Sometimes battles occur between forces that have been in place for weeks, carefully preparing their positions, while at other times a skirmish between patrols escalates into a major engagement, with reserves pouring in from other sectors. You can either agree with your opponent which type of deployment to use for your armies, or roll a D6 and consult the chart:

### DEPLOYMENT TYPE CHART

D6	Deployment type
1-2	Pitched Battle
3-4	Spearhead
5-6	Dawn of War

### A NOTE ON SECRECY

To keep things fair, you should always allow your opponent to read your force roster after a game. In the same spirit, always make clear to your opponent which squads are embarked in which transport vehicle. However, before starting to deploy their armies, it is a good idea for players to agree whether or not they can read the opponent's force roster before and during the game. Some players prefer full disclosure (which is the norm in tournaments, for example), as they want to concentrate on outmanoeuvring the enemy rather than springing a secret trump card on them. Others prefer to leave a feel of secrecy around their lists, as bluffing can make a game really entertaining. The choice is yours!

## MISSION SPECIAL RULES

All standard missions and deployment types use the following mission special rules, detailed on pages 94 and 95: 'reserves' and 'deep strike'.

## INFILTRATORS AND SCOUTS

In all three types of deployment, the sequence is the same. First the players deploy their forces (apart from any unit left in reserve or that chose to use their 'infiltrate' special rule). Then they deploy their infiltrators (as described on page 75), and finally they move units with the 'scouts' special rule (see page 76).

## MULTIPLE UNIT CHOICES

Note that occasionally the Codexes allow the player to include several units in his army at the cost of a single force organisation slot (like dedicated transports, etc.). Apart from being bought as a single choice, these units operate and count as separate units in all respects.

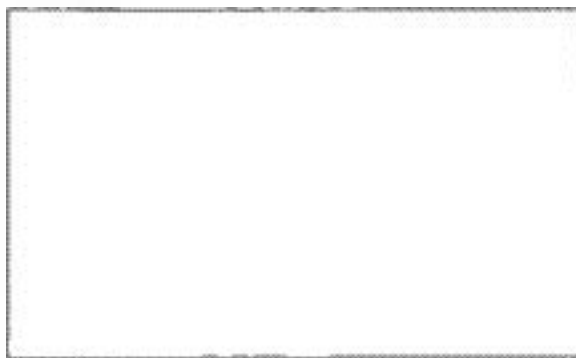

### PITCHED BATTLE – Long Table Edges

*In the most classic style of engagement, the two opposing forces deploy in battle formation and advance head-to-head, guns blazing.*

The table is divided lengthways into two halves, by drawing an imaginary line through the middle of the short table edges. For example, a 6'x4' table would have two 6'x2' halves.

The players roll-off, and the winner chooses to go first or second. The player that goes first then chooses one of the long table edges to be his own table edge. He then deploys his force in his half of the table, with all models more than 12" away from the table's middle line (this is his 'deployment zone'). His opponent then deploys in the opposite half.

Deploy any infiltrators and make any scout moves.

Start the game! Once deployment has finished, the player that chose his deployment zone first starts game Turn 1 with his first player turn.

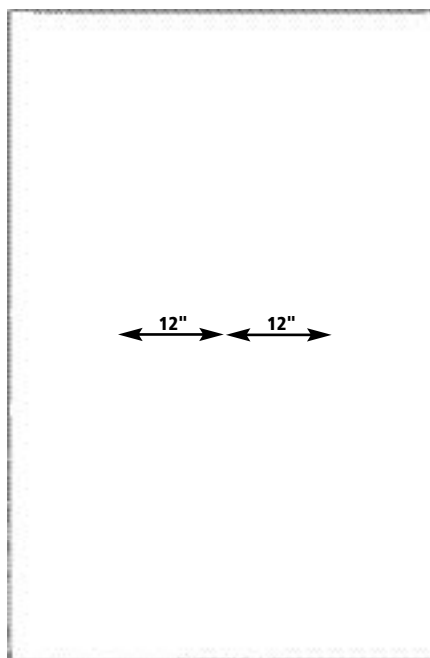

## SPEARHEAD – Table Quarters

*Both armies are trying to outflank the enemy, when contact is made and battle erupts.*

The table is divided into four quarters, formed by drawing two imaginary perpendicular lines through the centre point. So a 6'x4' table would have four 3'x2' quarters.

The players roll-off, and the winner chooses to go first or second. The player that goes first then chooses one of the long table edges to be his own table edge. He then deploys his force in one of the two table quarters on his side the table, more than 12" away from the centre of the table (this is his 'deployment zone'). His opponent then deploys in the diagonally opposite quarter.

Deploy any infiltrators and make any scout moves.

Start the game! Once deployment has finished, the player that chose his deployment zone first starts game Turn 1 with his first player turn.

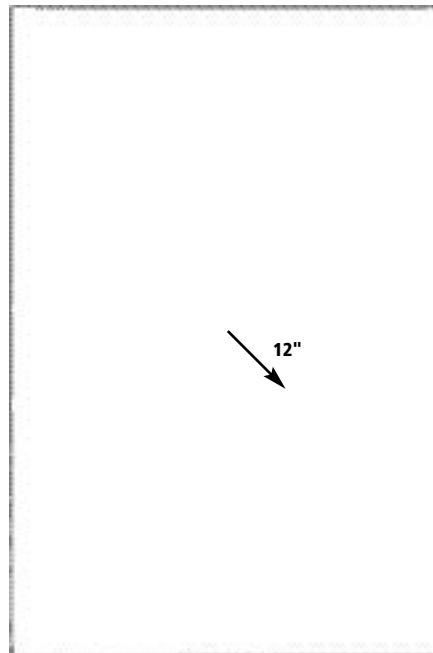

## DAWN OF WAR – Table Halves

*A clash of patrols escalates into a major engagement as the sun rises and reinforcements begin to pour in.*

The table is divided lengthways into two halves.

The players roll-off, and the winner chooses to go first or second. The player that goes first then chooses one of the long table edges to be his own table edge. He then can deploy up to two units from his Troops selections and up to one unit from his HQ selections in his half of the table (this is his 'deployment zone'). His opponent then does the same in the opposite half, but must position his three units more than 18" from enemy units.

Troops and HQ units that can infiltrate, can do so, as long as at the end of deployment the player still has a maximum of one HQ and two Troops units on the table. Lastly, players make any scout moves.

Start the game! Once deployment has finished, the player that chose his deployment zone first starts game Turn 1 with his first player turn.

All units that were not deployed, and were not declared to be in reserve during deployment, must enter the game in the Movement phase of their first player turn by moving in from their own table edge, just like units moving in from reserve.

During game Turn 1 the Night Fighting mission special rule is in effect.

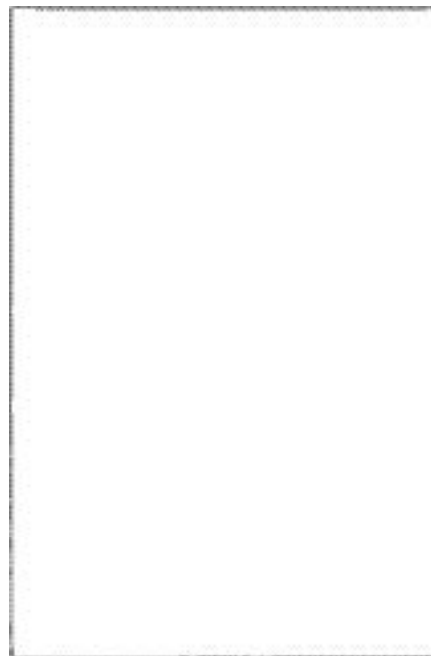

*Example: player A wins the roll-off and deploys an infantry unit from his Troops and one monstrous creature from his HQ, in his half of the table. He also declares that a second infantry unit from his Troops will use its Infiltrate ability. In his half of the table, player B then deploys a unit of Troops, already embarked into their dedicated transport (which is his second unit of Troops). He then deploys an independent character from his HQ, joining the unit embarked in the transport. Finally, player A deploys his infiltrating unit.*

## MISSION SPECIAL RULES

The 'reserves' and 'deep strike' special rules given here are used in all standard missions. 'Night fighting' is used with the Dawn of War deployment type.

Of course, players may like to add other special rules and design their own when creating new missions.

### RESERVES

Reserves are forces in the same sector as the units on the battlefield who can be called in to reinforce them at relatively short notice.

#### Preparing reserves

When deploying their army, players may choose not to deploy one or more of the units in their army and instead leave them in reserve. Units in reserve will become available in later turns of the game.

During deployment, when declaring which units are left in reserve, the player must clearly explain the organisation of his reserves to the opponent.

First he must specify to the opponent if any of his independent characters left in reserve are joining a unit, in which case they will be rolled for and will arrive together, or not in which case they will count as a separate unit when rolling for reserves.

Similarly, the player must specify if any transport vehicle in reserve is carrying any of the infantry units and/or independent characters in reserve. If they do, the unit and the transport will be rolled for together and will arrive together. Remember that a dedicated transport can only be deployed, and consequently can only be kept in reserve, either empty or transporting the unit it was selected with (plus any independent characters).

If units in reserve have the 'deep strike', 'scout' or 'infiltrate' special rule, the player must declare to his opponent, during army deployment, whether they are going to use their special rules to deep strike/outflank or they are going to enter from his own table edge when they will become available (see Arriving from Reserve). This decision may not be changed later.

#### Rolling for reserves

At the start of each of his Movement phases except the first, before moving any unit, the player must roll a dice for each of his units in reserve. Depending on the turn in question, a certain result will mean that the unit has arrived. For example, on Turn 1 no reserves arrive, on Turn 2 the player needs a 4+ for a unit to arrive, and so on until Turn 5, when any units left will arrive automatically (see the Reserves table on this page).

Once all of the units have been rolled for, the player picks any one of the units arriving and deploys it, moving it onto the table as described later. Then he picks another unit and deploys it, and so on until all

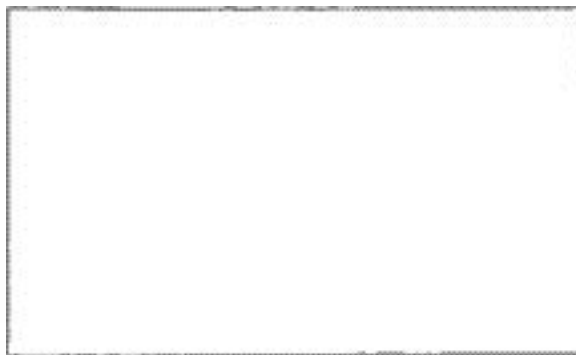

arriving units are on the table. The player may then proceed to move his other units as normal.

Note: you must roll for reserves as soon as possible and must bring them onto the table as soon as they are available. You may not delay making the dice rolls or keep the reserves hanging around off-table until you decide you need them!

#### Arriving from reserve

When a reserve unit arrives, it must move onto the table from the controlling player's own table edge (unless it's deep striking or outflanking). Each model's move is measured from the edge of the battlefield, as if they had been positioned just off the board in the previous turn and moved as normal. This means it is incorrect to place a model on the board touching the edge and then move it – this would mean it moved too far, especially in the case of large vehicles.

If a unit has a special rule forcing it to move in a specific direction (such as 'rage', for example) or that could stop it from moving, the rule is ignored in the phase when it arrives from Reserve.

Certain rare units are permanently immobile. If a unit like this cannot be deployed (for example in the Dawn of War deployment), or the player decides to keep it in reserve, it will enter the game by deep strike. This represents the immobile unit being airdropped or teleported into battle.

#### Outflank

During deployment, players may declare that units with the 'scout' or 'infiltrate' special rules are attempting to outflank the enemy. This means they are making a wide sweeping move to come at the foe from an unexpected direction. When an outflanking unit arrives from reserve the controlling player rolls a dice: on a 1-2 the unit will come in from the short table edge on the player's left; on a 3-4 they will come from the right, on a 5-6 the player can choose left or right. Models move onto the table as described for other reserves, above. Note that if such units are picked from their army list together with a dedicated transport, they may outflank with their transport, but if they do so they must move onto the table embarked in it.

## DEEP STRIKE

Some units' special rules allow them to enter play via tunnelling, teleportation, flying, or some other extraordinary means. If you wish to use this 'deep strike' option, then the units in question must begin the game in reserve (even if you are playing a special mission where the 'reserves' special rule is not being used). Roll for arrival of these units as specified in the rules for reserves and then deploy them as follows.

First place one model from the unit anywhere on the table, in the position you would like the unit to arrive, and roll the scatter dice. If you roll a hit the model stays where it is, but if an arrow is shown this determines the direction the model is scattered in. If a scatter occurs, roll 2D6 to see how many inches the model moves away from the intended position.

Once this is done, the unit's remaining models are arranged around the first one. Models must be placed in base contact with the original model in a circle around it. When the first circle is complete, a further circle should be placed with each model touching the circle inside it. Each circle should include as many models as will fit.

Models arriving via deep strike treat all difficult terrain as dangerous terrain.

In the Movement phase when they arrive, these units may not move any further, other than to disembark from a deep striking transport vehicle. Units deep striking into ruined buildings are placed on the ground floor. They may not deep strike directly inside a transport vehicle or a building, which will count as impassable terrain as normal.

In that turn's Shooting phase, these units can fire (or run) as normal, and obviously count as having moved in the previous Movement phase. Vehicles count as having moved at cruising speed.

In that turn's Assault phase, however, these units may not launch an assault (even if they have the 'fleet' special rule), unless clearly stated in their special rules – they are too disrupted by their deep strike move.

Note that some units always have the option to deep strike, while others may only arrive in this way in missions where the deep strike special rule is used. Of course all the standard missions presented here do use deep strike, so normally you won't need to worry about this distinction.

---

**Even a man who has nothing  
can still offer his life.**

---

## Deep strike mishaps

Teleporting or dropping onto a crowded battlefield may prove extremely dangerous, as one may arrive miles away from the intended objective or even inside solid rock! If any of the models in a deep striking unit cannot be deployed because they would land off the table, in impassable terrain, on top of a friendly model, or on top or within 1" of an enemy model, something has gone wrong. The controlling player must roll on the deep strike Mishap table and apply the results.

### DEEP STRIKE MISHAP TABLE

#### D6 Effect

- 1-2 Terrible accident!** Teleporting troops are lost in the Warp, deep striking jump infantry are shot down with their transport, or some other suitably dramatic event occurs. The entire unit is destroyed!
- 3-4 Misplaced.** Were the coordinates slightly inaccurate, or has the enemy jammed your instruments? Your opponent may deploy the unit anywhere on the table (excluding impassable terrain, but including difficult terrain, which of course counts as dangerous for deep striking units!), in a valid deep strike formation, but without rolling for scatter.
- 5-6 Delayed.** Because of mechanical failure or enemy action, the reinforcements are delayed. The unit is placed back in reserve. If the unit is unlucky enough to roll this result in turn 5 or later and then the game ends while it is still in reserve, it sadly counts as destroyed.

## NIGHT FIGHTING

It is much harder to accurately identify enemy units at night; warriors must be sure of their targets before opening fire, and tend to be more cautious than normal. After selecting a target, but before a unit fires, a check needs to be made to see if the firers can clearly spot their target through the darkness. Roll 2D6 and multiply the result by 3, then measure the distance between the two units (remember that distances to/from vehicles are measured to/from their hull, and not their guns). If the distance between the firing unit and their target is higher than the total rolled, the unit cannot fire at all in this Shooting phase, as they search the dark for a target that never appears.

Barrage and ordnance barrage weapons can still fire at targets in the dark, but if they do and fail to roll a hit, they add an extra D6" to the distance scattered.





# REFERENCE

Within these final pages you will find statistics for every troop type for each of the armies in Warhammer 40,000. Although the entries in this section are correct at the time of printing, the Warhammer 40,000 game system is constantly growing and developing. As such, in the event of any contradiction between this section and any of the individual codexes, the codexes always take precedence. We have also included rules for victory points. For players that want to use them, these provide a tiebreaker in the event of a draw, or a more detailed measure of which side has destroyed more of the enemy. At the back are summaries of the Movement, Shooting and Assault phase and the most commonly used charts for easy reference during battle.

---

**The universe is a big place and, whatever happens, you will not be missed...**

---

# SPACE MARINES

## SPACE MARINES

	WS	BS	S	T	W	I	A	Ld	Sv
Apothecary	4	4	4	4	1	4	2	9	3+
Attack Bike	4	4	4	4(5)	2	4	2	8	3+
Captain	5	5	4	4	3	5	3	10	3+ <sup>4+</sup>
Chaplain	4	4	4	4	2	4	2	10	3+ <sup>4+</sup>
Company	5	4	4	4	1	4	2	9	3+
Champion									
Honour Guard	4	4	4	4	1	4	2	10	2+
Librarian	5	4	4	4	2	4	2	9	3+
Scout	4	4	4	4	1	4	1	8	4+
Scout Biker	4	4	4	4(5)	1	4	1	8	4+
Scout Sergeant	4	4	4	4	1	4	2	8	4+
Servitor	3	3	3	3	1	3	1	8	4+
Space Marine	4	4	4	4	1	4	1	8	3+
Space Marine	4	4	4	4(5)	1	4	1	8	3+
Biker									
Techmarine	4	4	4	4	1	4	1	8	2+
Terminator	4	4	4	4	1	4	2	9	2+ <sup>5+</sup>
Veteran Sergeant	4	4	4	4	1	4	2	9	3+



## BLACK TEMPLARS

	WS	BS	S	T	W	I	A	Ld	Sv
Castellan	5	5	4	4	2	5	3	9	3+
Cenobyte	4	3	3	4	1	3	1	8	4+
Emperor's	6	4	4	4	2	5	2	10	2+ <sup>4+</sup>
Champion									
Initiate	4	4	4	4	1	4	1	8	3+
Marshal	5	5	4	4	3	5	3	10	3+
Neophyte	3	3	4	4	1	4	1	7	4+

## BLOOD ANGELS

	WS	BS	S	T	W	I	A	Ld	Sv
Death Company	4	4	4	4	1	4	2	9	3+

## DARK ANGELS

	WS	BS	S	T	W	I	A	Ld	Sv
Chaplain	5	5	4	4	2	5	3	9	3+ <sup>4+</sup>
Company	5	5	4	4	3	5	3	10	3+ <sup>4+</sup>
Master									
Interrogator-	5	5	4	4	3	5	3	10	3+ <sup>4+</sup>
Chaplain									
Librarian	5	5	4	4	2	5	3	9	3+
Ravenwing	4	4	4	4(5)	1	4	1	8	3+
Biker									
Veteran	4	4	4	4	1	4	2	9	3+

## SPACE WOLVES

	WS	BS	S	T	W	I	A	Ld	Sv
Wolf Guard	5	5	4	4	2	5	4	9	3+
Battle Leader									
Blood Claw	3	3	4	4	1	4	1	8	3+
Blood Claw	3	3	4	4(5)	1	4	1	8	3+
Biker									
Fenrisian Wolf	4	0	4	4	1	4	2	8	6+
Grey Hunter	4	4	4	4	1	4	1	8	3+
Iron Priest	5	5	4	4	2	5	3	9	2+
Long Fang	4	4	4	4	1	4	1	9	3+
Pack Leader	4	4	4	4	1	4	1	9	3+
Rune Priest	5	5	4	4	2	5	4	9	3+
Thrall	3	3	4	5	1	1	1	8	5+
Wolf Guard	4	4	4	4	1	4	2	9	3+
Wolf Lord	5	5	4	4	3	5	4	10	3+
Wolf Priest	5	5	4	4	2	5	4	10	3+ <sup>4+</sup>

<sup>4+</sup> Indicates a 4+ Invulnerable Save.

<sup>5+</sup> Indicates a 5+ Invulnerable Save.

## VEHICLES

	Armour			
	Front	Side	Rear	BS
Drop Pod	12	12	12	2
Land Raider	14	14	14	4
Land Raider Crusader	14	14	14	4
Leman Russ Exterminator	14	12	10	4
Land Speeder	10	10	10	4
Predator	13	11	10	4
Razorback	11	11	10	4
Rhino	11	11	10	4
Vindicator	13	11	10	4
Whirlwind	11	11	10	4

## DREADNOUGHTS

	Armour							
	WS	BS	S	Front	Side	Rear	I	A
Dreadnought	4	4	6(10)	12	12	10	4	2
'Furioso' Dreadnought	4	4	6(10)	12	12	10	4	2(3)
Space Wolf Venerable Dreadnought	5	5	6(10)	12	12	10	4	3

## WEAPONS

	Range	S	AP	Type
Assault cannon	24"	6	4	Heavy 4, Rending
Autocannon	48"	7	4	Heavy 2
Bolt pistol	12"	4	5	Pistol
Boltgun	24"	4	5	Rapid Fire
Deathwind	12"	5	6	Heavy 1, Large Blast
Demolisher	24"	10	2	Ordnance 1, Large Blast
Flamer	Template	4	5	Assault 1
Heavy bolter	36"	5	4	Heavy 3
Heavy flamer	Template	5	4	Assault 1
Hunter-killer missile	n/a	8	3	Heavy 1
Lascannon	48"	9	2	Heavy 1
Meltagun	12"	8	1	Assault 1, Melta
Missile Launcher*				
<i>Frag</i>	48"	4	6	Heavy 1, Blast
<i>Krak</i>	48"	8	3	Heavy 1



	Range	S	AP	Type
Multi-melta	24"	8	1	Heavy 1, Melta
Plasma pistol	12"	7	2	Pistol, Gets Hot!
Plasma gun	24"	7	2	Rapid Fire, Gets Hot!
Plasma cannon	36"	7	2	Heavy 1, Blast, Gets Hot!
Shotgun				
Solid shot	12"	3	-	Assault 2
Manstopper	12"	4	-	Assault 2
Sniper rifle	36"	X	6	Heavy 1, Sniper, Pinning
Storm bolter	24"	4	5	Assault 2
Typhoon missile	48"	5	5	Heavy 1, Blast, Twin-linked
Whirlwind**				
<i>Vengeance</i>	G12-48"	5	4	Ord. 1/Large Blast
<i>Castellan</i>	G12-48"	n/a	n/a	Ord. 1/Large Blast
<i>Incendiary Castellan</i>	G12-48"	4	5	Ord. 1/Large Blast, Ignores Cover

# IMPERIAL GUARD

	WS	BS	S	T	W	I	A	Ld	Sv
Commissar	4	4	3	3	2	4	2	10	5+
Conscript	2	2	3	3	1	3	1	5	5+
Guardsmen	3	3	3	3	1	3	1	7	5+
Hardened Veteran	3	4	3	3	1	3	1	8	5+
Hardened Veteran Sergeant	3	4	3	3	1	3	2	8	5+
Heroic Senior Officer	4	4	3	3	3	4	3	9	5+
Junior Officer	3	3	3	3	1	3	2	8	5+
Ogryn	4	3	5	4	3	3	2	8	5+
Ogryn Bone 'ead	4	3	5	4	3	3	3	9	5+
Priest	3	3	3	3	2	4	2	8	–
Ratling	2	4	2	2	1	4	1	6	5+
Sanctioned Psyker	2	2	3	3	1	3	1	8	5+
Senior Officer	4	4	3	3	2	4	3	8	5+
Veteran Sergeant	3	3	3	3	1	3	2	8	5+
Storm Trooper	3	4	3	3	1	3	1	8	4+
Storm Trooper	3	4	3	3	1	3	2	8	4+
Veteran Sergeant	3	3	3	3	1	3	1	8	3+
Tech-Priest	3	3	3	3	1	3	1	8	3+
Engineer									



## VEHICLES

	Armour			
	Front	Side	Rear	BS
Basilisk	12	10	10	3
Chimera	12	10	10	3
Demolisher	14	13	11	3
Hellhound	12	12	10	3
Leman Russ	14	12	10	3

	Armour							
	WS	BS	S	Front	Side	Rear	I	A
Sentinel	3	3	5	10	10	10	3	1

Weapons	Range	S	AP	Type
Autocannon	48"	7	4	Heavy 2
Battle cannon	72"	8	3	Ord. 1, Large Blast
Boltgun	24"	4	5	Rapid fire
Bolt pistol	12"	4	5	Pistol
Demolisher	24"	10	2	Ord. 1, Large Blast
Earthshaker	120"	9	3	Ord. 1, Large Blast
Flamer	Template	4	5	Assault 1
Grenade launcher*				
Frag	24"	3	6	Assault 1, Blast
Krak	24"	6	4	Assault 1
Heavy bolter	36"	5	4	Heavy 3
Heavy flamer	Template	5	4	Assault 1
Heavy stubber	36"	4	6	Heavy 3
Hellpistol	12"	3	5	Pistol
Hellgun	24"	3	5	Rapid fire
Hunter-killer missile	n/a	8	3	Heavy 1
Inferno cannon**	24"	6	4	Heavy 1, Template
Lasgun	24"	3	–	Rapid fire
Laspistol	12"	3	–	Pistol
Lascannon	48"	9	2	Heavy 1
Meltagun	12"	8	1	Melta, Assault 1
Missile launcher*				
Frag	48"	4	6	Heavy 1, Blast
Krak	48"	8	3	Heavy 1
Mortar	G48"	4	6	Heavy 1, Blast
Multi-laser	36"	6	6	Heavy 3
Multi-melta	24"	8	1	Melta, Heavy 1
Plasma cannon	36"	7	2	Gets Hot, Heavy 1, Blast
Plasma gun	24"	7	2	Gets Hot, Rapid Fire
Plasma pistol	12"	7	2	Gets Hot, Pistol
Ripper gun	12"	4	6	Assault 2
Shotgun	12"	3	–	Assault 2
Sniper rifle	36"	–	6	Sniper, Pinning, Heavy 1
Storm bolter	24"	4	5	Assault 2

\* May fire either frag or krak missiles/grenades.

\*\* Place flamer template on target. Roll to hit. If you hit, all models touched by template are hit. If you miss, they are hit on a 4+.

# FORCES OF THE IMPERIUM

## AGENTS OF THE IMPERIUM

	WS	BS	S	T	W	I	A	Ld	Sv
Arco-flagellant	4	0	4	5	1	4	1/D6	8	- <sup>4+</sup>
Crusader	4	3	3	3	1	3	1	8	4+ <sup>4+</sup>
Daemonhost	4	4	6	4	4	4	D6	9	- <sup>4+</sup>
Death Cult Assassin	5	4	4	3	2	5	2	8	- <sup>5+</sup>
Henchman	3	3	3	3	1	3	1	8	6+
Imperial Assassin	5	5	4	4	2	5	3	10	- <sup>4+</sup>
Inquisitor	4	4	3	3	2	4	2	8	4+
Inquisitor Lord	4	4	3	3	3	4	3	10	3+
Priest	3	3	3	3	2	4	2	8	-
Storm Trooper	3	4	3	3	1	3	1	8	4+
Warrior Henchman	3	4	3	3	1	3	1	8	4+

## GREY KNIGHTS

	WS	BS	S	T	W	I	A	Ld	Sv
Grand Master	5	5	4	4	3	5	4	10	2+ <sup>5+</sup>
Grey Knight	5	4	4	4	1	4	1	8	3+
Brother-Captain	5	4	4	4	1	4	3	10	2+ <sup>5+</sup>
Grey Knight Terminator	5	4	4	4	1	4	2	10	2+ <sup>5+</sup>
Justicar	5	4	4	4	1	4	2	9	3+

<sup>4+</sup> Indicates a 4+ Invulnerable Save. <sup>5+</sup> Indicates a 5+ Invulnerable Save.

## BATTLE SISTERS

	WS	BS	S	T	W	I	A	Ld	Sv
Battle Sister	3	4	3	3	1	3	1	8	3+
Canoness	4	5	3	3	3	4	3	10	3+
Celestian	4	4	3	3	1	4	1	9	3+
Celestian Superior	4	4	3	3	1	4	2	9	3+
Mistress	4	4	3	3	1	4(5)	2(3)	10	4+
Palatine	4	5	3	3	2	4	2	9	3+
Seraphim	4	4	3	3	1	4	1	9	3+
Seraphim Superior	4	4	3	3	1	4	2	9	3+
Sister Repentia	4	4	3(6)	3	1	3	1	6	4+
Sister Superior	3	4	3	3	1	3	2	9	3+

## VEHICLES

	Armour			
	Front	Side	Rear	BS
Chimera	12	10	10	3
Exorcist	13	11	10	4
Immolator	11	11	10	4
Land Raider	14	14	14	4
Land Raider Crusader	14	14	14	4
Rhino	11	11	10	4

## VEHICLES (cont.)

	Armour							
	WS	BS	S	Front	Side	Rear	I	A
Dreadnought	5	4	6(10)	12	12	10	4	2
Penitent Engine	4	2	5(10)	11	11	10	3	D6

Weapons	Range	S	AP	Type
Assault Cannon	24"	6	4	Heavy 3
Boltgun	24"	4	5	Rapid fire
Bolt pistol	12"	4	5	Pistol
Exorcist missile	48"	8	1	Heavy D6
Flamer	Template	4	5	Assault 1
Heavy bolter	36"	5	4	Heavy 3
Heavy flamer	Template	5	4	Assault 1
Hellpistol	12"	3	5	Pistol
Hellgun	24"	3	5	Rapid fire
Incinerator	Template	5	4	Assault 1; no Inv. or Cover Saves
Inferno pistol	6"	8	2	Pistol; melta
Laspistol	12"	3	-	Pistol
Lascannon	48"	9	2	Heavy 1
Meltagun	12"	8	1	Melta, Assault 1
Multi-laser	36"	6	6	Heavy 3
Multi-melta	24"	8	1	Melta, Heavy 1
Needle pistol	12"	-	6	Pistol; wounds on 4+
Psycannon*	18"	6	4	Assault 3; ignores Invulnerable Saves
<i>*May be fired as an assault or a heavy weapon.</i>	36"	6	4	Heavy 3; ignores Invulnerable Saves
Shotgun	12"	3	-	Assault 2
Storm bolter	24"	4	5	Assault 2
Stake crossbow	24"	3	5	Assault 2; wounds psykers on 2+ with no Save.

ORBITAL WEAPONS	S	AP	Notes
Barrage bomb	6	4	Ord blast
Lance strike	10	1	Ord blast
Melta torpedo	8	3	Ord blast; 2D6 Armour Pen
Psyk-out	9	1	See Codex: Witch Hunters

## NEMESIS FORCE WEAPON BONUSES

Rank	Strength bonus	Power weapon	Force weapon
Grey Knight	+2	No	No
Grey Knight Brother-Captain	+2	Yes	No
Grey Knights Grand Master	+2	Yes	Yes
Grey Knight Justicar/Terminator	+2	Yes	No

# CHAOS SPACE MARINES

	WS	BS	S	T	W	I	A	Ld	Sv
Aspiring Champion	4	4	4	4	1	4	2	10	3+
Aspiring Sorcerer	4	4	4	4	1	4	2	10	3+ <sup>4+</sup>
Berzerker	5	4	4	4	1	4	2	9	3+
Berzerker Skull Champion	5	4	4	4	1	4	3	10	3+
Chaos Biker	4	4	4	4(5)	1	4	1	9	3+
Chaos Biker Aspiring Champion	4	4	4	4(5)	1	4	2	10	3+
Chaos Lord	6	5	4	4	3	5	3	10	3+ <sup>5+</sup>
Chaos Space Marine	4	4	4	4	1	4	1	9	3+
Chaos Spawn	3	0	5	5	3	3	D6	10	-
Chosen Chaos Space Marine	4	4	4	4	1	4	1	10	3+
Noise Marine	4	4	4	4	1	5	1	9	3+
Noise Marine Champion	4	4	4	4	1	5	2	10	3+
Obliterator	4	4	4	4	2	4	2	9	2+ <sup>5+</sup>
Plague Marine	4	4	4	4(5)	1	3	1	9	3+
Plague Marine Champion	4	4	4	4(5)	1	3	2	10	3+
Possessed	4	4	5	4	1	4	2	10	3+ <sup>5+</sup>
Raptor	4	4	4	4	1	4	1	9	3+
Sorcerer	5	5	4	4	3	5	3	10	3+ <sup>5+</sup>
Space Marine Daemon Prince	7	5	6	5	4	5	4	10	3+ <sup>5+</sup>
Summoned Greater Daemon	8	0	6	6	4	4	5	10	- <sup>4+</sup>
Summoned Lesser Daemon	4	0	4	4	1	4	2	10	- <sup>5+</sup>
Terminator	4	4	4	4	1	4	2	10	2+ <sup>5+</sup>
Terminator Champion	4	4	4	4	1	4	3	10	2+ <sup>5+</sup>
Thousand Sons Marine	4	4	4	4	1	4	1	9	3+ <sup>4+</sup>

<sup>4+</sup> Indicates a 4+ Invulnerable Save.

<sup>5+</sup> Indicates a 5+ Invulnerable Save.

"I murdered thousands for the Emperor and he gave me nothing except his damning silence. Now his lapdogs yap for every life I take, while the gods promise me the galaxy."

Svanc Vulfbad

## VEHICLES

	Armour			
	Front	Side	Rear	BS
Chaos Land Raider	14	14	14	4
Chaos Predator	13	11	10	4
Chaos Rhino	11	11	10	4
Chaos Vindicator	13	11	10	4

	Armour							
	WS	BS	S	Front	Side	Rear	I	A
Chaos Dreadnought	4	4	6	12	12	10	4	3
Defiler	3	3	6	12	12	10	3	3

Weapon	Range	S	AP	Type
Autocannon	48"	7	4	Heavy 2
Battle cannon	72"	8	3	Ord. 1, Large Blast
Blastmaster*				
Varied frequency	36"	5	4	Assault 2, Pinning
Single frequency	48"	8	3	Heavy 1, Blast, Pinning
Bolt pistol	12"	4	5	Pistol
Boltgun	24"	4	5	Rapid Fire
Demolisher	24"	10	2	Ord. 1, Large Blast
Doom siren	Template	5	3	Assault 1
Flamer	Template	4	5	Assault 1
Havoc Launcher	48"	5	5	Heavy 1, Blast Twin-linked
Heavy bolter	36"	5	4	Heavy 3
Heavy flamer	Template	5	4	Assault 1
Lascannon	48"	9	2	Heavy 1
Meltagun	12"	8	1	Melta, Assault 1,
Missile launcher**				
Frag	48"	4	6	Heavy 1, Blast
Krak	48"	8	3	Heavy 1
Plasma Cannon	36"	7	2	Heavy 1, Blast, Gets Hot!
Plasma Gun	24"	7	2	Rapid Fire; Gets hot
Plasma Pistol	12"	7	2	Pistol, Gets hot!
Reaper				Heavy 2,
Autocannon	36"	7	4	Twin-linked
Sonic blaster	24"	4	5	Assault 2 or Heavy 3***

\* May fire either at a single or varied frequency.

\*\* May fire either frag or krak missiles.

\*\*\* May fire either Assault 2 or Heavy 3

# CHAOS DAEMONS

	WS	BS	S	T	W	I	A	Ld	Sv*
Beast of Nurgle	3	0	4	5	2	2	D6	10	-5+
Bloodcrusher	5	0	5	5	2	4	3	10	4+ <sup>5+</sup>
Bloodletter	5	0	4	4	1	4	2	10	-5+
Bloodthirster	10	4	7	6	4	5	5	10	4+ <sup>3+</sup>
Daemon Prince	7	5	5	5	4	5	4	10	-5+
Daemonette	4	0	3	3	1	6	3	10	-5+
Flesh Hound	4	0	4	4	1	4	2	10	-5+
Fury	3	0	4	4	1	3	2	10	-5+
Great Unclean One	6	4	6	6	5	2	4	10	-4+
Keeper of Secrets	8	4	6	6	4	10	6	10	-4+
Khorne Herald	6	3	4	4	2	5	3	10	-5+
Lord of Change	5	5	6	6	4	5	3	10	-3+
Nurgle Herald	4	3	4	5	2	3	2	10	-5+
Nurglings	2	0	3	3	3	2	3	10	-5+
Pink Horror	2	3	3	3	1	3	1	10	-4+
Plaguebearer	3	0	4	5	1	2	1	10	-5+
Screamer	3	0	4	4	1	3	1	10	-4+

	WS	BS	S	T	W	I	A	Ld	Sv*
Seeker	4	0	3	3	1	6	4	10	-5+
Slaanesh Fiend	3	0	4	4	2	5	3	10	-5+
Slaanesh Herald	5	3	3	3	2	7	4	10	-5+
Tzeentch Flamer	2	4	4	4	1	3	2	10	-4+
Tzeentch Herald	2	4	3	3	2	4	2	10	-4+

<sup>3+</sup> Indicates a 3+ Invulnerable Save.  
<sup>4+</sup> Indicates a 4+ Invulnerable Save.  
<sup>5+</sup> Indicates a 5+ Invulnerable Save.

## VEHICLES

	Armour							
	WS	BS	S	Front	Side	Rear	I	A
Soul Grinder	3	3	6(10)	13	13	11	3	4

Weapon	Range	S	AP	Type
Mawcannon				
vomit	template	6	4	Assault 1
tongue	24"	10	1	Assault 1
phlegm	36"	8	3	Assault 1, large blast
Harvester	24"	4	5	Assault 6

# TYRANIDS

	WS	BS	S	T	W	I	A	Ld	Sv
Biovore	3	3	4	4	2	1	1	5	6+
Broodlord	6	3	5	5	3	7	4	10	4+
Carnifex	3	2	9	6	4	1	2	10	3+
Gargoyle	3	3	3	3	1	4	1	10	6+
Gaunt	3	3	3	3	1	4	1	5	6+
Genestealer	6	0	4	4	1	6	2	10	5+
Hive Tyrant	5	3	5	6	4	5	3	10	3+
Hormagaunt	4	3	3	3	1	4	2	5	6+
Lictor	6	0	6	4	2	6	3	10	5+
Ravener	5	3	4	4	2	5	3	10	5+
Ripper Swarm	3	1	3	3	3	2	3	10	6+
Spore Mine	0	0	1	3	1	1	0	5	-
Tyrant Guard	5	3	5	6	2	5	3	10	3+
Warrior	4	2	4	4	2	4	2	10	5+
Zoanthrope	3	3	4	4	2	4	2	10	2+ <sup>6+</sup>

<sup>6+</sup> indicates a 6+ Invulnerable Save.

Weapon	Range	S	AP	Type
Barbed strangler	36"	S-1	5	Assault 1/large blast, pinning, Max Str 8
Deathspitter	24"	S+1	5	Assault 1 Blast, Max Str 7
Devourer	18"	S-1	-	Assault 2X, Max Str 6
Fleshborer	12"	S+1	5	Assault X, Max Str 6
Spinefist	12"	S	5	Assault X, Max Str 6 Twin linked
Venom cannon*	36"	S+2	4	Assault X

\*Maximum Strength = 10. Can only cause glancing hits against vehicles that are not open-topped.

S indicates that the Strength of the weapon is the same as the Strength of the model firing it. This is sometimes modified by a number written next to S, and/or has a maximum value.

X indicates that the rate of fire of the weapon is equal to the Attacks value of the model firing it (this is sometimes multiplied by a number written next to X).

Note: if a Tyranid Monstrous Creature fires two identical weapons, it counts as firing a single twin-linked weapon.

# ELDAR

	WS	BS	S	T	W	I	A	Ld	Sv
Autarch	6	6	3	3	3	6	3	10	3+ <sup>4+</sup>
Avatar	10	5	6	6	4	6	4	10	3+
Dark Reaper	4	4	3	3	1	5	1	9	3+
Death Jester	5	4	3	3	1	6	2	9	–
Dire Avenger	4	4	3	3	1	5	1	9	4+
Exarch	5	5	3	3	1	6	2	9	3+*
Farseer	5	5	3	3	3	5	1	10	–
Fire Dragon	4	4	3	3	1	5	1	9	4+
Guardian	3	3	3	3	1	4	1	8	5+
Guardian Jetbike	3	3	3	3(4)	1	4	1	8	3+
Harlequin	5	4	3	3	1	6	2	9	–
Howling Banshee	4	4	3	3	1	5	1	9	4+
Phoenix Lord	7	7	4	4	3	7	4	10	2+
Ranger	3	4	3	3	1	4	1	8	5+
Shadowseer	5	4	3	3	1	6	2	9	–
Shining Spear	4	4	3	3(4)	1	5	1	9	3+
Striking Scorpion	4	4	3	3	1	5	1	9	3+
Swooping Hawk	4	4	3	3	1	5	1	9	4+
Troupe Master	5	4	3	3	1	6	3	10	–
Warlock	4	4	3	3	1	4	1	8	–
Warp Spider	4	4	3	3	1	5	1	9	3+
Wraithguard	4	4	5	6	1	4	1	10	3+
Wraithlord	4	4	10	8	3	4	2	10	3+

<sup>4+</sup> Indicates a 4+ Invulnerable Save.

## VEHICLES

	Armour			
	Front	Side	Rear	BS
Falcon	12	12	10	3
Fire Prism	12	12	10	4
Vyper	10	10	10	3
Wave Serpent	2	12	10	3

	Armour							
	WS	BS	S	Front	Side	Rear	I	A
War Walker	3	3	5	10	10	10	4	2

“Ask not the Eldar a question, for they will give you three terrifying answers, all of which are true and terrifying to know.”

Inquisitor Czevak

## WEAPON

	Range	S	AP	Type
Avenger	18"	4	5	Assault 2
shuriken catapult				
Bright lance	36"	8	2	Heavy 1, Lance
D-cannon*	G24"	X	2	Heavy 1, Blast
Deathspinner	12"	6	–	Assault 2
Dragon's breath flamer	Template	5	4	Assault 1
Exarch deathspinner	12"	6	–	Assault 4
Firepike	18"	8	1	Assault 1, Melta
Flamer	Template	4	5	Assault 1
Fusion gun	12"	8	1	Assault 1, Melta
Fusion pistol	6"	8	1	Pistol, Melta
Hawk's talon	24"	5	5	Assault 3
Lasblaster	24"	3	5	Assault 2
Laser lance	6"	6	4	Assault 1, Lance
Eldar missile launcher				
<i>Krak</i>	48"	8	3	Heavy 1
<i>Plasma</i>	48"	4	4	Heavy 1, Blast, Pinning
Prism cannon* (focussed)	60"	9	2	Heavy 1, Blast
Prism cannon* (dispersed)	60"	5	4	Heavy 1, Large Blast
Pulse laser	48"	8	2	Heavy 2
Ranger long rifle*	36"	X	6	Heavy 1, Sniper, Pinning
Reaper launcher	48"	5	3	Heavy 2
Scatter laser	36"	6	6	Heavy 4
Singing spear*	12"	X	6	Assault 1
Shadow weaver	G48"	6	–	Heavy 1, Blast
Shrieker cannon	24"	6	5	Assault 3, Pinning
Shuriken cannon	24"	6	5	Assault 3
Shuriken catapult	12"	4	5	Assault 2
Shuriken pistol	12"	4	5	Pistol
Spinneret rifle	18"	6	1	Assault 1, Pinning
Star lance	6"	8	4	Assault 1, Lance
Starcannon	36"	6	2	Heavy 2
Sunrifle	24"	3	5	Assault 6, Pinning
Tempest launcher	G36"	4	3	Heavy 2, Blast
Triskele	12"	3	2	Assault 3
Vibro cannon*	36"	4	–	Heavy 1, Pinning
Wraithcannon*	12"	X	2	Assault 1

\* These weapons have additional rules. See the Eldar Wargear section.

\*\* May fire either plasma or krak missiles.

# DARK ELDAR

	WS	BS	S	T	W	I	A	Ld	Sv
Archon	6	6	3	3	3	7	3	9	5+
Beastmaster	4	4	3	3	1	6	1	8	6+
Dracon	5	5	3	3	2	6	2	9	5+
Grotesque	4	0	4	3	2	3	2	5	n/a
Haemonculus	4	4	3	4	2	4	2	8	5+
Hellion	4	4	3	3	1	6	1	8	5+
Hellion	4	4	3	3	1	6	2	8	5+
Succubus									
Incubi Master	5	4	3	3	1	6	2	9	3+
Incubi	5	4	3	3	1	5	1	8	3+
Mandrake	4	4	3	3	1	5	1	8	5+
Reaver	4	4	4	4	1	6	1	8	4+
Reaver	4	4	4	4	1	6	2	8	4+
Succubus									
Scourge	4	4	3	3	1	5	1	8	5+
Sybarite	4	4	3	3	1	5	2	8	5+
Talos	5	3	7	7	3	4	D6	n/a	3+
Warrior	4	4	3	3	1	5	1	8	5+
Warp Beast	4	0	4	3	1	5	3	3	6+
Wych	4	4	3	3	1	6	1	8	6+
Wych Archite	6	6	3	3	3	8	3	9	6+
Wych Dracite	5	5	3	3	2	7	2	9	6+
Wych	4	4	3	3	1	6	2	8	6+
Succubus									

## VEHICLES

	Armour			BS
	Front	Side	Rear	
Raider	10	10	10	4
Ravager	11	11	10	4

## WEAPON

Range	S	AP Type		
Blaster	12"	8	2	Lance, Assault 1
Dark lance	36"	8	2	Lance, Heavy 1
Destructor	Template	4	D6	Assault 1
Disintegrator*				
Maximum	36"	7	2	Heavy 1, Blast
Sustained	24"	4	3	Heavy 3
Shredder	12"	6	-	Assault 1, Blast
Splinter cannon	24"	4	5	Assault 4
Splinter pistol	12"	3	5	Pistol
Splinter rifle	24"	3	5	Rapid Fire
Stinger**	12"	n/a	6	Assault 1, Wounds on 2+
Terrorfex***	12"	n/a	n/a	Assault 1, Blast
Talos sting	24"	4	5	Assault 6

\*May fire either at maximum or sustained.

\*\*If target killed, place Blast marker over it. S = target's T; AP = target's Armour Save.

\*\*\*Only roll to hit. If 1+ models hit, their unit must make a Pinning test.

-1 modifier if unit under half strength;

-1 modifier per model hit if more than one model is hit.



# ORKS

	WS	BS	S	T	W	I	A	Ld	Sv
'Ard Boy	4	2	3	4	1	2	2	7	4+
Big Mek	4	2	4	4	2	3	3	8	6+
Burna Boy	4	2	3	4	1	2	2	7	6+
Dethkopta	4	2	3	4(5)	2	2	2	7	4+
Flash Gitz	4	2	4	4	2	3	3	7	4+
Gretchin	2	3	2	2	1	2	1	5	-
Kommando	4	2	3	4	1	3	2	7	6+
Loota	4	2	3	4	1	2	2	7	6+
Meganob	4	2	4	4	3	2	3	7	2+
Mek	4	2	3	4	1	2	2	7	6+
Nob	4	2	4	4	2	3	3	7	6+
Ork Boy	4	2	3	4	1	2	2	7	6+
Painboy	4	2	4	4	2	3	3	7	6+
Runtherd	4	2	4	4	2	3	3	7	6+
Stormboy	4	2	3	4	1	2	2	7	6+
Tankbusta	4	2	3	4	1	2	2	7	6+
Warbiker*	4	2	3	4(5)	1	2	2	7	6+
Warboss	5	2	5	5	3	4	4	9	6+
Weirdboy	4	2	4	4	2	3	3	7	6+

## VEHICLES

	Armour			BS
	Front	Side	Rear	
Battlewagon	14	12	10	2
Looted wagon	11	11	10	2
Trukk	10	10	10	2
Warbuggy/WarTrak/Skorcha	10	10	10	2

	Armour							
	WS	BS	S	Front	Side	Rear	I	A
Deff Dread	4	2	5(10)	12	12	10	2	3
Killa Kan	2	3	5(10)	11	11	10	2	2

## WEAPON

	Range	S	AP	Type
Big shoota	36"	5	5	Assault 3
Boomgun	36"	8	3	Ordnance 1, Large Blast
Burna	Template	4	5	Assault 1
Deffgun	48"	7	4	Heavy D3
Grot blasta	12"	3	-	Assault 1
Grotzooka	18"	6	5	Heavy 2, Blast
Kannon*				
<i>Frag</i>	36"	4	5	Heavy 1, Blast
<i>Shell</i>	36"	8	3	Heavy 1
Killkannon	24"	7	3	Ordnance 1, Large Blast
Kustom	24"	8	2	Heavy 1
Mega-Blasta				Gets Hot!
Lobba	G48"	5	5	Heavy 1, Blast
Rokkit launcha	24"	8	3	Assault 1
Shokk	60"	2D6	2	Ordnance, Heavy 1
Attack Gun				Large Blast
Shoota	18"	4	6	Assault 2
Skorcha	Template	5	4	Assault 1
Slugga	12"	4	6	Pistol
Zzap gun**	36"	2D6	2	Heavy 1

\* See Codex: Orks for more details.

\*\* See Codex: Orks for more details. Zzap guns do not roll to hit.

"I'm da hand of Gork and Mork. Dey sent me to rouse up da boyz to crush and kill 'cos da boyz forgot what dere 'ere for.

I' da profit of the Waaagh 'an whole worlds burn in my boot prints."

Ghazghkull Mag Uruk Thraka



# TAU EMPIRE

	WS	BS	S	T	W	I	A	Ld	Sv
Broadside	2	3	5	4	2	2	2	8	2+
Shas'ui									
Broadside	3	3	5	4	2	3	2	8	2+
Shas'vre									
Crisis Shas'el	3	4	5	4	3	3	3	9	3+
Crisis Shas'o	4	5	5	4	4	3	4	10	3+
Crisis Shas'ui	2	3	5	4	2	2	2	8	3+
Crisis Shas'vre	3	3	4	3	1	3	2	8	3+
Ethereal	4	3	3	3	2	3	3	10	-
Fire Warrior	2	3	3	3	1	2	1	7	4+
Shas'la									
Fire Warrior	2	3	3	3	1	2	2	8	4+
Shas'ui									
Gun Drone	2	2	3	3	1	4	1	7*	4+
Kroot	4	3	4	3	1	3	1	7	-/6
Kroot Hound	4	0	4	3	1	5	2	7	-/6
Krootox Rider	4	3	6	3	3	3	3	7	-/6
Marker Drone	2	2(3)	3	3	1	4	1	n/a	4+
Shaper	4	3	4	3	3	3	3	8	6
Shield Drone	2	2	3	**	1	4	1	n/a	**/4+
Sniper Drone	2	2(3)	3	3	1	4	1	7	4+
Spotter	2	3(4)	3	3	1	2	1	8	4+
Stealth Shas'ui	2	3	4	3	1	2	2	8	3+
Stealth Shas'vre	3	3	4	3	1	3	2	8	3+
Strain Leader	3	3	3	4	1	5	1	9	5+
Vespid	3	3	3	4	1	5	1	6	5+
Stingwing									

\*Gun Drones' Leadership is only applicable when operating in independent squadrons.  
 \*\*Shield Drones share the Toughness and save of the model they accompany. They also have a 4+ Invulnerable Save.

## VEHICLES

	Armour			
	Front	Side	Rear	BS
Devilfish Troop Carrier	12	11	10	3
Hammerhead Gunship	13	12	10	3(4)
Piranha Light Skimmer	11	10	10	3
Sky Ray Missile	13	12	10	3
Defence Gunship				

## WEAPON

	Range	S	AP	Type
Burst cannon	18"	5	5	Assault 3
Flamer	Template	4	5	Assault 1
Fusion blaster	12"	8	1	Assault 1, Melta
Ion cannon	60"	7	3	Heavy 3
Kroot gun	48"	7	4	Rapid Fire
Kroot rifle*	24"	4	6	Rapid Fire
Markerlight*	36"	n/a	n/a	Heavy 1
Missile pod	36"	7	4	Assault 2
Plasma rifle	24"	6	2	Rapid Fire
Pulse rifle	30"	5	5	Rapid Fire
Pulse carbine	18"	5	5	Assault 1, Pinning
Pulse pistol	12"	5	5	Pistol
Railgun (solid shot)	72"	10	1	Heavy 1
Railgun (submunition)	72"	6	4	Heavy 1, 5" Blast Hammerhead only
Rail rifle	36"	6	3	Heavy 1, Pinning
Seeker missile*	Unlimited	8	3	Heavy 1
Smart missile system*	24"	5	5	Heavy 4
Vespid neutron blaster	12"	5	3	Assault 1

\*These weapons have additional rules.  
 See the Tau Vehicle Upgrades and Wargear sections in Codex: Tau Empire.



# NECRONS

	WS	BS	S	T	W	I	A	Ld	Sv
Flayed Ones	4	4	4	4	1	4	2	10	3+
Necron	4	4	4	5	1	2	1	10	3+
Destroyer									
Necron	4	4	4	5	1	2	1	10	3+
Immortal									
Necron Lord	4	4	5	5	3	4	3	10	3+
Necron Warrior	4	4	4	4	1	2	1	10	3+
Necron Wraiths	4	4	6	4	1	6	3	10	- <sup>3+</sup>
Pariahs	4	4	5	5	1	3	1	10	3+
Scarab Swarm	2	0	3	3	3	2	3	10	5+
The Nightbringer	6	4	10	8	5	4	5	10	- <sup>4+</sup>
The Deceiver	5	3	9	8	5	5	4	10	- <sup>4+</sup>
Tomb Spydery	2	2	6	6	2	2	3	10	3+

<sup>4+</sup> Indicates a 4+ Invulnerable Save.

<sup>3+</sup> Indicates a 3+ Invulnerable Save.

## VICTORY POINTS

Sometimes a mission ends in a draw, whether it be on objectives, kill points, or other victory conditions in missions of your own design. While most gamers will be happy to know that on this occasion they were equally matched, more competitive players may like to have a 'tiebreaker' to determine which side has done marginally better. Alternatively, you might have inflicted so much damage on the enemy army that you would like to be able to claim at least a moral victory!

This may also be useful in tournaments, where the organisers need a better spread of results among the players, so some finer degrees of victory may be useful. To cover these situations, players may agree to calculate victory points (VPs). VPs are gained by inflicting damage on enemy units, as follows.

### Units destroyed

At the end of the game every unit that has been destroyed is worth an amount of VPs equal to its points cost (including the cost of all its extra wargear, vehicle upgrades, etc). Units that end the game falling back or off the battlefield count as destroyed.

*For example, a 260 point Land Raider would be worth 260 VPs to the opponent if he managed to destroy it by the end of the game.*

### VEHICLES

	Armour			
	Front	Side	Rear	BS
Monolith	14	14	14	4

### WEAPON

	Range	S	AP	Type
Gauss blaster	24"	5	4	Assault 2, Gauss
Gauss cannon	36"	6	4	Heavy 3, Gauss
Gauss flayer	24"	4	5	Rapid Fire, Gauss
Gauss flux arc	12"	5	4	Heavy D6 per unit within 12", Gauss
Heavy	36"	9	2	Heavy 1
Gauss cannon				
Particle whip	24"	9	3	Ordnance1, Large Blast
Staff of Light	12"	5	3	Assault 3

### Units at half strength

At the end of the game every enemy surviving unit that has lost half of its initial models or more is worth an amount of VPs equal to half its points cost (including the cost of all its extra wargear, vehicle upgrades, etc), rounded down. In the case of units that start the game as a single model (independent characters, monstrous creatures, etc), they are worth half their points cost in VPs if they have lost half or more of the Wounds on their profile. In the case of vehicles, they are worth half their points cost in VPs if they are suffering from the effects of any Damaged result at the end of the game.

*For example, a squad of Space Marines starts the game at 10 models strong (costing 190 points) and ends the game with only 5 models left. Such a squad is worth 95 VPs to the opponent.*

### Moral victory?

Each player adds together all of the VPs he has scored by damaging enemy units, then the two totals are compared to find the difference in VPs. A difference of less than 10% of the game's points limit (i.e. 150 VPs in a 1,500 point battle) means you really were evenly matched. A bigger difference would show that one side has seriously maimed the enemy's force, even though it failed to best them on objectives, and that player has at least earned the bragging rights.

# QUICK REFERENCE SHEET

## TURN SEQUENCE

- 1 The Movement Phase
- 2 The Shooting Phase
- 3 The Assault Phase

## SHOOTING SEQUENCE

- 1 Pick one of your units, check its line of sight and choose a target for it.
- 2 Check range.
- 3 Roll to hit.
- 4 Roll to wound.
- 5 Take saving throws.
- 6 Remove casualties.

## ASSAULT PHASE

- 1 Move assaulting units
- 2 Defenders react
- 3 Resolve combats

## ROLL TO HIT (SHOOTING)

**Firer's BS**                    **1 2 3 4 5**  
 Score needed to hit    **6 5 4 3 2**

## MORALE CHECKS

### A unit takes a Morale check:

- If it takes 25% or more casualties in a single phase (close combat casualties do not count) – test at the end of the phase.
- If an enemy tank performs a Tank Shock attack on them – test once the tank has moved into contact.
- If it is defeated in close combat in the Assault phase – test once combat results are established. The unit's Leadership is modified by -1 for every point their side has lost the combat by.

## DIFFICULT TERRAIN – EFFECTS ON MOVEMENT

Unit Type	Slowed by difficult terrain?	Dangerous Terrain test required?
Infantry	Yes	No*
Bikes	No	Yes
Jetbikes	No	Only if move starts/ends in the terrain
Monstrous creatures	Yes	No*
Jump Infantry	No	Only if move starts/ends in the terrain
Artillery	Yes	No for crew*. Yes for gun models.
Beasts & Cavalry	Yes	No*
Vehicles – Walkers	Yes	No*
Vehicles – Skimmers	No	Only if move starts/ends in the terrain
Vehicles – Other	No	Yes

\* unless terrain is also categorised as dangerous

## RESERVES TABLE

Turn	Unit arrives on
1	N/A
2	4+
3	3+
4	2+
5+	Automatic

## COVER CHART

Cover Type	Save
• Razor wire, Wire mesh	6+
• High Grass, Crops, Bushes, Hedges, Fences	5+
• Units (friends and enemies) Trenches, Gun pits, Tank traps, Emplacements, Sandbags,  Barricades, Logs, Pipes, Crates, Barrels, Hill crests, Woods, Jungles, Wreckage, Craters, Rubble, Rocks, Ruins, Walls, Buildings, Wrecked vehicles	4+
• Fortification	3+

## RESOLVING COMBATS

- 1 Pick a combat.
- 2 Fight Close Combat. Engaged models roll to hit and to wound in Initiative order. Their opponents take Saving throws as required.
- 3 Determine Assault Results. Total up wounds inflicted. The side which inflicted the most wounds overall in the combat is the winner.
- 4 Loser Checks Morale. The loser has to pass a Morale check or fall back. If the loser passes the test, go directly to Pile In.
- 5 Sweeping Advances, Fall backs and Consolidations. Units falling back from close combat must test to see if they successfully break off, if they fail they are destroyed. The winners may then consolidate their position.
- 6 Pile In. If units are still locked in close combat, then any models not engaged are moved 6" towards the enemy to continue the fight next turn.
- 7 Pick another combat and repeat until all combats have been resolved.

## TO HIT CHART (Assault)

		Opponent's Weapon Skill									
		1	2	3	4	5	6	7	8	9	10
Attacker's Weapon Skill	1	4+	4+	5+	5+	5+	5+	5+	5+	5+	5+
	2	3+	4+	4+	4+	5+	5+	5+	5+	5+	5+
	3	3+	3+	4+	4+	4+	4+	5+	5+	5+	5+
	4	3+	3+	3+	4+	4+	4+	4+	4+	5+	5+
	5	3+	3+	3+	3+	4+	4+	4+	4+	4+	4+
	6	3+	3+	3+	3+	3+	4+	4+	4+	4+	4+
	7	3+	3+	3+	3+	3+	3+	4+	4+	4+	4+
	8	3+	3+	3+	3+	3+	3+	3+	4+	4+	4+
	9	3+	3+	3+	3+	3+	3+	3+	3+	4+	4+
	10	3+	3+	3+	3+	3+	3+	3+	3+	3+	4+

## TO WOUND CHART

		Toughness									
		1	2	3	4	5	6	7	8	9	10
Strength	1	4+	5+	6+	6+	N	N	N	N	N	N
	2	3+	4+	5+	6+	6+	N	N	N	N	N
	3	2+	3+	4+	5+	6+	6+	N	N	N	N
	4	2+	2+	3+	4+	5+	6+	6+	N	N	N
	5	2+	2+	2+	3+	4+	5+	6+	6+	N	N
	6	2+	2+	2+	2+	3+	4+	5+	6+	6+	N
	7	2+	2+	2+	2+	2+	3+	4+	5+	6+	6+
	8	2+	2+	2+	2+	2+	2+	3+	4+	5+	6+
	9	2+	2+	2+	2+	2+	2+	2+	3+	4+	5+
	10	2+	2+	2+	2+	2+	2+	2+	2+	3+	4+

## WEAPON TYPE SUMMARY

(not for vehicles)

Weapon Type	Moving and Firing	Firing and Assaulting
<b>Pistol</b>	Can move and fire once	May fire once in the Shooting phase and then assault the same enemy unit in the Assault phase. Counts as an additional weapon in close combat.
<b>Rapid Fire</b>	Fire twice at up to 12", or remain stationary and fire once up to maximum weapon range.	Unit may not assault if the weapon was fired in the Shooting phase (unless allowed to by a special rule).
<b>Assault</b>	Can move and fire normally.	May fire in the Shooting phase and then assault the same enemy unit in the assault phase.
<b>Heavy</b>	Cannot move and fire.	Unit may not assault if the weapon was fired in the Shooting phase (unless allowed to by a special rule).

## VEHICLE DAMAGE TABLE

D6	Result	Modifiers:
1	Crew – Shaken	Glancing Hit -2
2	Crew – Stunned	Hit by 'AP-' weapon -1
3	Damaged – Weapon Destroyed	Hit by 'AP1' weapon +1
4	Damaged – Immobilised	Target is open-topped +1
5	Destroyed – Wrecked	
6	Destroyed – Explodes!	

## DEEP STRIKE MISHAP TABLE

D6	Effect
1-2	Terrible accident! The entire unit is destroyed!
3-4	Misplaced. Your opponent may deploy the unit anywhere on the table (including inside difficult terrain, which of course counts as dangerous for Deep Striking units!), in a valid Deep Strike formation, but without rolling for scatter.
5-6	Delayed. The unit is placed back in reserve. If the unit is unlucky enough that the game ends while it is still in reserve, it counts as destroyed.

## VEHICLES' MOVING & SHOOTING SUMMARY CHART

	Stationary	Combat Speed	Cruising Speed	Flat Out
<b>All (except Fast &amp; Walkers)</b>	All Weapons	1 Weapon*	No Weapons	N/A
<b>Fast</b>	All Weapons	All Weapons	1 Weapon*	No Weapons
<b>Walker</b>	All Weapons	All Weapons	N/A	N/A

*\*plus all defensive weapons.*

# INDEX

- Access points, 66
- Allocating wounds, 39
- Area terrain, 13
- Armour penetration, 60
- Armour Piercing (AP), 27
- Armour piercing weapons, 20
- Armour Save (Sv), 7, 20
- Armour Value (AV), 56
- Artillery, 55
- Assault phase, 33
  - Assault phase summary, 33
  - Assault results, 41
  - Assaulting multiple enemy units, 34
  - Assaulting through cover, 36
  - Assaulting vehicles, 63
  - Assaults while falling back, 46
  - Attacking, 41
  - Declare assaults, 33
  - Defenders react, 34
  - Determine assault results, 39
  - Disallowed assaults, 33
  - Fighting a close combat, 34
  - Move assaulting units, 34
  - Multiple combats, 41
  - Number of attacks, 37
  - Rolling To Hit, 37
  - Rolling To Wound, 38
  - Shooting into and out of close combat, 40
- Assault weapons, 28
- Attacks (A), 6
  - Ballistic Skill (BS), 6
    - Ballistic Skill of 6 or better, 18
  - Barrage, 32
  - Bases, 3
  - Battlefield, prepare the, 88
  - Beasts, 54
  - Bikes, 53
  - Blast, 30, 84
  - Buildings, 77, 78
    - Assaults, 85
    - Attacking, 79
    - Buildings armour chart, 79
    - Defining, 77
    - Firing from, 79
    - Occupying, 79
    - Parapets/battlements, 80
  - Casualties, 24, 39
  - Cavalry, 54
  - Characteristics, 6, 56
    - Tests, 8
  - Characters, 47
  - Choose forces, 86
  - Close combat weapons, 42, 50, 73
  - Consolidation, 40
  - Counter-attack, 74
  - Cover, 21, 62
    - Cover chart, 21
    - Cover saves, 21
    - Vehicles & cover, 62
    - Wrecks as cover, 62
  - Damage results, 61
    - Effects on passengers, 67
  - Damage rolls, 61
  - Dangerous terrain, 14
  - Dawn of war, 93
  - Death or glory!, 69
  - Declare assaults, 33
  - Dedicated transports, 67
  - Deep strike, 95
    - Deep strike mishap table, 95
  - Defensive weapons, 58
  - Deploy forces, 92
  - Dice, 2
  - Disembarking, 67
  - Dreadnought close combat weapons, 73
  - Embarking, 66
  - Ending the game, 90
  - Eternal warrior, 74
  - Fall back!, 45
    - Assaults while falling back, 46
    - Firing while falling back, 46
    - from close combat, 45
    - Morale while falling back, 46
  - Fast vehicles, 70
  - Fearless, 75
  - Feel no pain, 75
  - Fire points, 66
  - Fleet, 75
  - Force organisation, 86
  - Force organisation chart, 87
  - Force weapons, 50
  - Furious charge, 75
  - Game turn, 9
  - Gets hot!, 31
  - Going to ground, 24
  - Grenades, 36, 63
  - Heavy weapons, 29
  - Hit and run, 75
  - Impassable buildings, 77, 78
  - Impassable terrain, 14
  - Independent characters, 47, 67
    - Assaults, 49
    - Joining and leaving units, 48
    - Moving independent characters, 47
    - Shooting, 49
  - Infiltrate, 75
  - Initiative (I), 6
  - Instant death, 26
  - Intervening models, 21
  - Invulnerable saves, 20
  - Jet packs, 52
  - Jetbikes, 53
  - Jump infantry, 52
  - Lance, 32
  - Leadership (LD), 7
    - Leadership tests, 8
  - Lightning claws, 42
  - Line of sight, 16
  - Maximum range, 27
  - Measuring distances, 3, 56
  - Melta, 32
  - Mission, select a, 90
  - Mission special rules, 94
  - Models, 3
  - Monstrous creatures, 51
  - Morale, 43, 63
    - Insane heroism!, 43
    - modifiers, 43
    - Morale checks, 39, 43
    - Morale while falling back, 46
    - Vehicles and morale, 63
  - Move through cover, 75
  - Movement phase, 11
    - Different movement distances in a unit, 11
    - Models in the way, 11
    - Movement distance, 11
    - Moving and close combat, 11
    - Moving through difficult terrain, 14
    - Vehicle movement, 57
  - Multiple-wound models, 26
  - Night fighting, 95
  - Night vision/acute senses, 75
  - No retreat!, 44
  - Obscured targets, 62
  - Open-topped vehicles, 70
    - Open-topped transport vehicles, 70
  - Optional weapons, 58
  - Ordnance barrage weapons, 58
  - Ordnance weapons, 29, 58
  - Organising a battle, 86
  - Perils of the Warp, 50
  - Pile-in!, 40
  - Pinning, 31
  - Pistol weapons, 29
  - Pitched battle, 92
  - Player turn, 9
  - Points limit, 86
  - Points values, 8
  - Poisoned weapons, 42
  - Power fists, 42
  - Power weapons, 42
  - Preferred enemy, 75
  - Profiles, 7
  - Psychic shooting attacks, 50
  - Psykers, 50
  - Rage, 76
  - Ramming, 69
  - Rapid fire weapons, 28
  - Re-rolls, 2
  - Regrouping, 46
  - Relentless, 76
  - Rending, 31
  - Rending weapons, 42
  - Reserves, 94
    - Reserves table, 94
  - Retinues, 48
  - Roads, 57
  - Roll-offs, 2
  - Ruins, 77, 82
    - Coping with different heights, 82
    - Moving within, 83
    - Template and blast weapons, 84
  - Run!, 16

**Saving throws, 20**  
 More than one save, 24  
 Taking saves, 39  
**Scoring units, 90**  
**Scouts, 76**  
**Seize the initiative!, 92**  
**Shooting phase, 15**  
 Check range, 17  
 Disallowed shooting, 15  
 Firing while falling back, 46  
 Roll To Hit, 17  
 Roll To Wound, 19  
 Shooting at vehicles, 60  
 Shooting into & out of close combat, 40  
 Shooting sequence, 15  
 Skilled rider, 76  
 Vehicles shooting, 58  
**Skimmers, 71**  
**Slow and purposeful, 76**  
**Smoke launchers, 62**  
**Sniper, 31**  
**Spearhead, 93**  
**Special characters, 49**  
**Squadrons, 64**  
**Standard missions chart, 90**  
**Stealth, 76**  
**Strength, 27**  
**Strength (S), 6**  
**Stubborn, 76**  
**Swarms, 76**  
**Sweeping advances, 40**

**Tank hunters, 76**  
**Tanks, 68**  
 Tank shock!, 68  
**Template, 29, 84**  
**Terrain, 13**  
 Area terrain, 13  
 Moving through difficult terrain, 14  
 Types of, 13  
 Terrain effects, 57  
**Thunder hammers, 42**  
**To Hit chart, 37**  
**To Wound chart, 19, 38**  
**Toughness (T), 6**  
 Multiple Toughness values, 19, 38  
**Transport vehicles, 66**  
 Transport capacity, 66  
 Dedicated transports, 67  
 Effects of damage, 67  
**Trapped, 45**  
**Turbo-boosters, 76**  
**Twin-linked, 31**  
**Turn, the, 9**  
 Game turn, 9  
 Player turn, 9  
  
**Unique characters, 49**  
**Unit coherency, 12, 82**  
**Unit types, 4, 51**  
**Units, 3**

**Vehicles, 56**  
 Assaulting vehicles, 63  
 Measuring distances to vehicles, 56  
 Shooting at vehicles, 60  
 Types, 65  
 Units of vehicles – squadrons, 64  
 Vehicles and cover – obscured targets, 62  
 Vehicles and morale, 63  
 Vehicle characteristics, 56  
 Vehicle Damage table, 61  
 Vehicle facing and armour values, 60  
 Vehicles moving & shooting summary chart, 73  
 Vehicles shooting, 58  
 Weapons & line of sight, 58  
**Vulnerable to blasts/templates, 76**  
  
**Walkers, 72**  
 Ramming a walker, 73  
 Squadrons of walkers, 73  
**Weapon Skill (WS), 6**  
**Weapons, 27**  
 Type, 27  
**Wipeout!, 90**  
**Witchblades, 42**  
**Wounds (W), 6**  
 Multiple-wound models, 26  
  
**Zero-level Characteristics, 7**

## ROLL OF HONOUR

The Warhammer 40,000 game first came into existence over 20 years ago in the Games Workshop Studio in rain-sodden Nottingham, England. The toiling Tech-Priest who wrote its first Standard Template Construction blueprint was Rick Priestley. The dark and gothic artistic vision came from John Blanche. Countless contributions and admonishments were brought to bear by Alan Merrett. Throughout the writing of this edition of the game we often had to fire up the arcane support machineries that (mostly) keep this revered trinity stabilised. Their advice has been invaluable.

**Written by:** Alessio Cavatore (main rules), Mat Ward, Andy Hoare, Graham Davey, Phil Kelly, Gav Thorpe, Adam Troke, Robin Cruddace, Jervis Johnson, Jeremy Vetock.  
**Cover Art:** Alex Boyd, Dave Gallagher, Nuala Kinrade. **Illustration:** John Blanche, Alex Boyd, Paul Dainton, Dave Gallagher, Nuala Kinrade, Robin Carey, Karl Kopinski, Adrian Smith, Roberto Cirillo, Ian Miller. **Miniature Design:** Alexander Hedstrom, Aly Morrison, Brian Nelson, Colin Grayson, David Thomas, Juan Diaz, Mark Harrison, Martin Footitt, Michael Anderson, Seb Perbet, Tim Adcock, Neil Langdown,

Chris Catton, Dale Stringer, Jonny Ware, Tom Walton, Jes Goodwin, Trish Morrison.  
**'Eavy Metal:** Neil Green, Keith Robertson, Kirsten Williams, Darren Latham, Fil Dunn, Anja Wettergren, Joe Tomaszewski. **Hobby Team:** Dave Andrews, Mark Jones, Chad Mierzwa. **Graphic Elements:** Neil Hodgson, Paul Rudge. **Graphic Design, Layout and Production:** Pete Borlace, Markus Trenker, Sean Turtle, Tim Vincent, John Michelbach, Carl Dafforn, Marc Elliot, Kris Jagers, Rachel Ryan, Chris Eggar, Simon Burton, Marc Elliott, Chris Ward, Sean Cutler, James Shardlow, Kris Shields, Madeleine Tighe. **Photography:** Stuart White, Ian Strickland, Glenn More, Kenton Mills. **Additional Hobby Content:** Matt Hutson, Dave Taylor, Paul Scott, John Shaffer, Andrew Taylor, Matt Toone, Dave Cross. **Sub-Editing:** Andrew Kenrick, Mark Latham, Talima Fox. **Thanks to:** Everyone who provided feedback and playtested the rules.

Several Astropaths, Servo-scribes and Tech-adepts were lost to the Dark Powers during the making of this product (they will be remembered).

Copyright © Games Workshop Ltd 2008. Assault on Black Reach, Games Workshop, the Games Workshop logo, GW, Citadel and the Citadel device, 'Eavy Metal, Eldar symbol devices, Eye of Terror, Warhammer, Warhammer 40,000, the Warhammer 40,000 device, the Double-Headed/Imperial Eagle device, 40K, Battle for Macragge, the Chaos factions and associated logos, Space Marine, Space Marine Chapters and Space Marine Chapter insignia, Eldar, Tyranid, Genestealer, Golden Demon, the Tau caste designations, Tau, Fire Warrior, Kroot, Necron, Ork, Ork devices, Chaos and all associated marks, the 'In the Grim Darkness of the Far Future' tagline, names, races and race insignia, characters, vehicles, locations, units, illustrations and images from the Warhammer 40,000 universe are either ®, TM and/or © Games Workshop Ltd 2000-2008, variably registered in the UK and other countries around the world. All Rights Reserved. 'Scatter' dice are UK registered design no. 2017484.

British Cataloguing-in-Publication Data. A catalogue record for this book is available from the British Library.

**UK**  
**Games Workshop**  
 Willow Rd, Lenton  
 Nottingham  
 NG7 2WS

**US**  
**Games Workshop**  
 6721 Baymeadow Drive  
 Glen Burnie  
 Maryland, 21060-6401

**Australia**  
**Games Workshop**  
 23 Liverpool Street  
 Ingleburn  
 NSW 2565

**Canada**  
**Games Workshop**  
 2679 Bristol Circle,  
 Units 2&3, Oakville  
 Ontario, L6H 6Z8

**Japan**  
**Games Workshop**  
 Willow Rd, Lenton  
 Nottingham  
 NG7 2WS, UK

GW10 LID 2/3 Core



602701990118

